

# Asimetría y balance de momento de jets y las propiedades del plasma de quarks y gluones

*M. Elena Tejeda-Yeomans*<sup>1,2</sup>,  
A. Ayala<sup>2</sup>, I. Domínguez<sup>3</sup>, J. Jalilian-Marian<sup>4</sup>

<sup>1</sup>Depto. de Física, Universidad de Sonora

<sup>2</sup>Instituto de Ciencias Nucleares, UNAM

<sup>3</sup>Fac. de Ciencias, Universidad de Sinaloa

<sup>4</sup>Baruch College, CUNY

Seminario de Física de Altas Energías  
ICN-UNAM, IF-UNAM  
29 de octubre, 2014

# Outline

- 1 Relativistic heavy ion collisions
- 2 Learning from different observables
- 3 Asymmetry and momentum balance from pQCD + Eloss
- 4 Questions, answers and to-do lists
- 5 Preliminary results
- 6 The importance of being  $2 \rightarrow 3$
- 7 Final remarks

# Nuclear physics programs at RHIC and LHC

- primary goal: to study high temperature QCD
- collide large nuclei at extremely high energies
- hot matter created where nucleons are no longer the relevant dof
- QGP: quarks and gluons are deconfined over an extended volume
- first observables:  $\gamma$ 's radiated from this matter indicate  
 $T_0 \sim 220 \text{ MeV}$
- hottest matter ever created in the lab!

# Collision evolution diagram

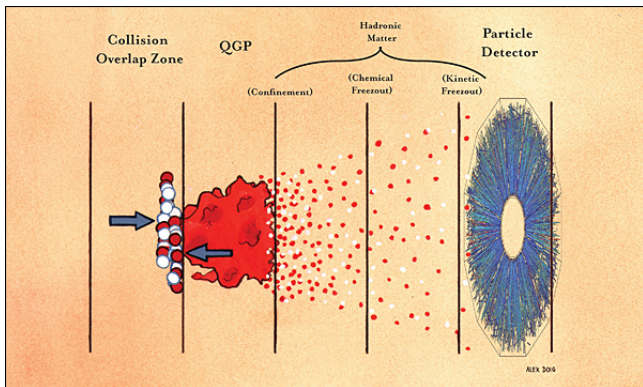

for Au+Au collisions: 197 protons and neutrons per nucleus

QGP created thousands or even millions of times per sec @RHIC

inside the QGP: q's and g's in soup  $250,000 \times$  hotter than center of the sun

10-22 seconds: for q's and g's to freeze back into hadrons

(diagram of Ágnes Mócsy, [see ref later](#))

# What do we observe?

bulk matter well described by hydro models with small  $\eta/s$   
matter is nearly opaque to the passage of high  $p_T$  quarks and gluons  
(up to the highest measured momenta and the heaviest measured quarks)

basic probes high  $p_T$  quarks and gluon produced by hard (large momentum transfer) QCD processes (probe on short length scales and lose energy via gluon bremsstrahlung and multiple scattering)

# Collisions and observation

- features of particle angular correlations in heavy-ion, proton-proton ( $pp$ ), proton-lead ( $p+Pb$ ), deuteron-gold ( $d+Au$ ) collisions and gold-gold collisions ( $Au+Au$ )
- emergence of structures very different from di-jet expectations in  $pp$  collisions in vacuum:
  - small azimuthal angle (near-side) large pseudorapidity correlation, the *ridge* (also observed in large-multiplicity  $pp$ ,  $p+Pb$ , and  $d+Au$  collisions)
  - broadening in large azimuthal angle (away-side) correlation

# Ridge

Schematic diagram of ridge (Ágnes Mócsy)

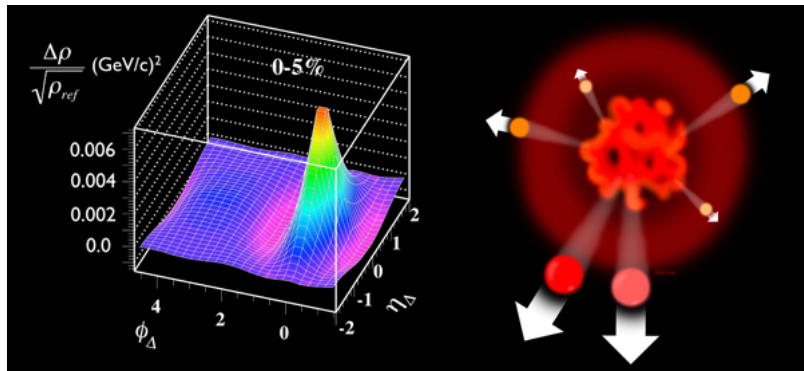

# Jet-quenching

High- $p_T$  particle production  $\rightarrow$  strongly suppressed in heavy-ion collisions relative to  $pp$  collisions

STAR NPA 757  
(2005): Peak  
suppressed at  
 $\Delta\phi = \pm\pi$  rad

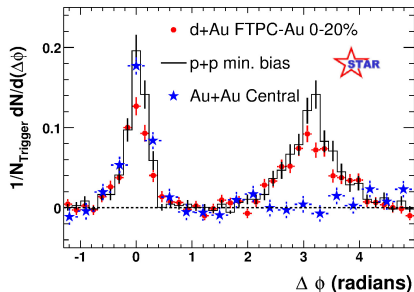

# Jet-quenching

STAR NPA 757  
(2005): Peak  
suppressed at  
 $\Delta\phi = \pm\pi$  rad

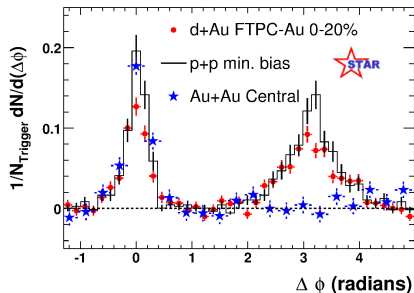

Why?

parton E-loss in the high density medium

and its energy distribution is a steeply falling function

surviving high  $p_T$ -particles with minimal interactions with the medium

# Single and di-hadron production

- Surface bias: medium intrn probability increases with the path length
- Two sides of the story:
  - single high  $p_T$  hadrons sensitive to partons directed outward (from the near-surface region of the collision zone)  $\Rightarrow$  limited information of QCD medium and jet-medium intrns
  - jet production is back-to-back in LO QCD  $\Rightarrow$  away-side jet partner opposite to a high- $p_T$  particle with a long path-length, maximizing probability of in-medium intrn
- single and di-hadron production as complementary measurements
  - useful to constrain the magnitude of geometrical dependence of E-loss

# Dijet momentum (im)balance

Use the asymmetry ratio

$$A_J = \frac{p_{T,1} - p_{T,2}}{p_{T,1} + p_{T,2}}$$

where

- 1, leading; 2, subleading; so  $A_J > 0$
  - $p_{T,1} > 120$  GeV/c and  $p_{T,2} > 50$  GeV/c
  - $A_J$  near  $p_{T,1}$  threshold:  $A_J < 0.41$
  - 300 GeV/c leading jets  $A_J = 0.7$
- pp data at  $\sqrt{s} = 7$  TeV and PbPb data at  $\sqrt{s} = 2.76$  TeV

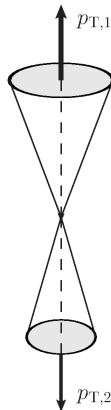

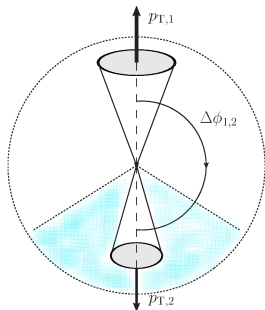
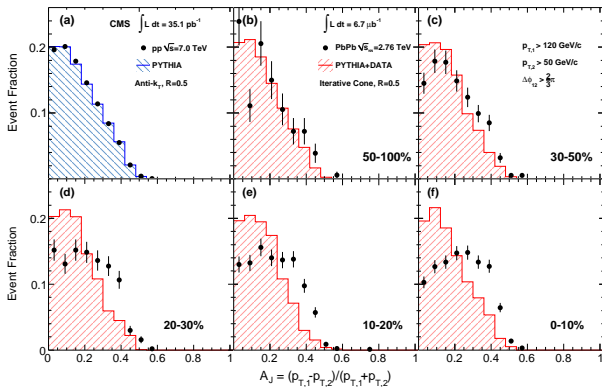
CMS 2011, asymmetry in PbPb at  $\sqrt{s} = 2.76$  TeV

Phys.Rev.C84:024906,2011; arXiv:1102.1957 [nucl-ex]

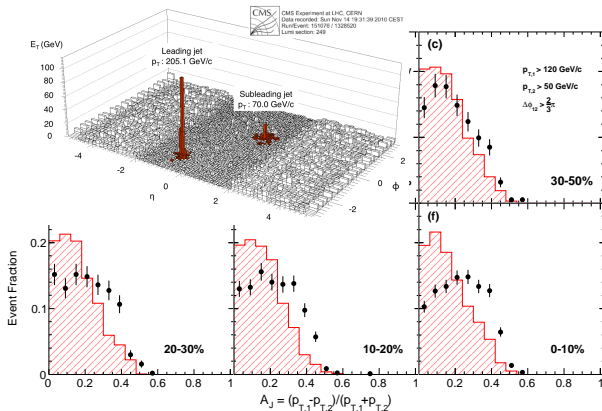
CMS 2011, asymmetry in PbPb at  $\sqrt{s} = 2.76$  TeV

For most central bins

→ **deficit** of balanced pairs and **excess** of unbalanced pairs

Dijet momentum (im)balance: missing  $p_T$ 

Another way to learn about overall momentum balance in dijet events: per event, project tracks onto leading jet axis and build

$$\langle p_T^{\parallel} \rangle = \frac{1}{N} \sum_{i \in \text{all tracks}} -p_T^i \cos(\phi_i - \phi_L)$$

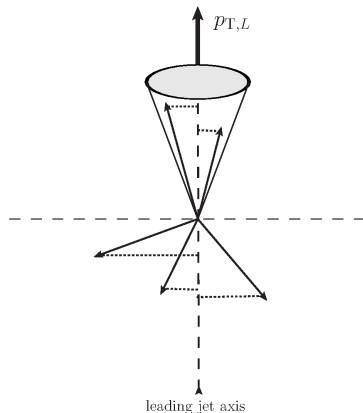

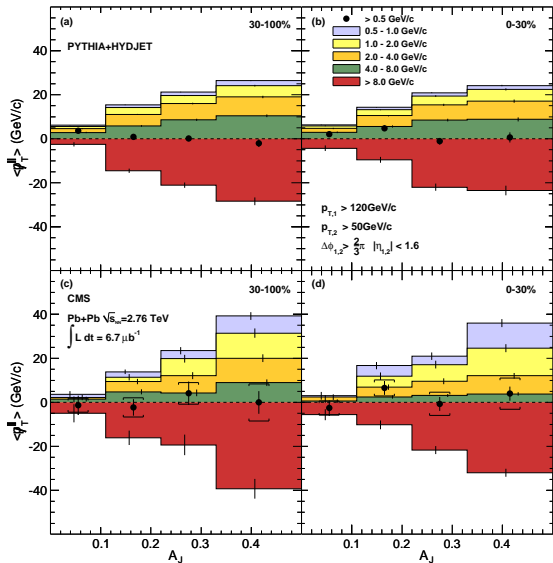
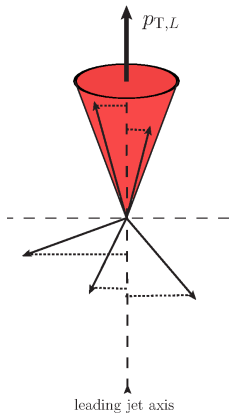
CMS 2011, missing  $p_T$  in PbPb at  $\sqrt{s} = 2.76$  TeV

CMS 2011, missing  $p_T$  in PbPb at  $\sqrt{s} = 2.76$  TeV

→ solid circles:  
momentum balance  
of events, recovered  
within uncertainties

- ✓ for both  
centrality ranges
- ✓ even for large  
asymmetry

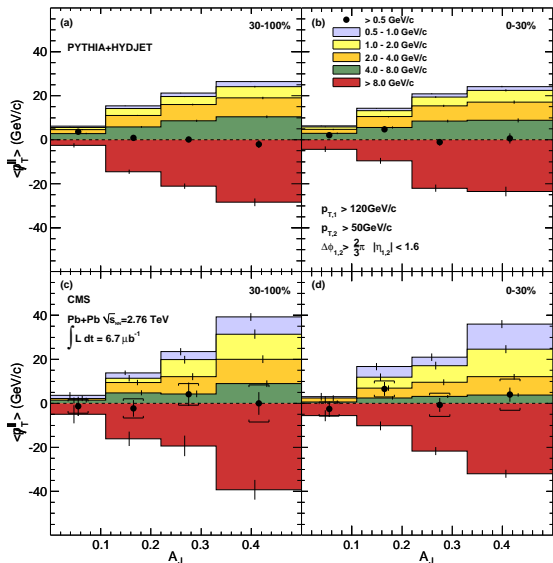

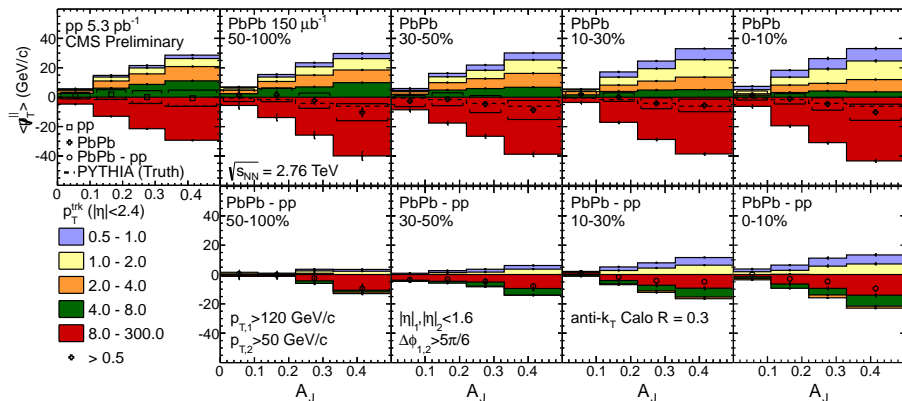
CMS 2014, missing  $p_T$  in PbPb at  $\sqrt{s} = 2.76$  TeV

→ Events balanced to within 10 GeV/c.

May 2014, CMS PAS HIN-14-010

# CMS simulated data samples

- enhance Pythia dijets in the momentum range studied,  $p_T < 80$  GeV/c
- PYTHIA dijet events processed with full detector simulation and analysis chain
- Additional samples produced: PYTHIA dijet events embedded into min bias PbPb events at the raw data level
- embedding: real PbPb data events and PbPb events simulated with HYDJET event generator
- for the  $A_J > 0.33$  selection,  $\gtrsim 10\%$  of PYTHIA dijet events are 3-jet events

# Questions

- ✓ Distribution of events in asymmetry: how can we understand this deficit of balanced pairs vs excess of unbalanced pairs?
  - Overall balance of  $p_T$ : how can we understand the structure of the away side for  $p_T < 8 \text{ GeV}/c$ ?
  - Geometry: surface emission vs bulk emission / more asymmetric vs more symmetric
  - Energy loss  $\leftrightarrow$  in/out-of cone rad

# Answers so far...

- Measurement: 3 contributions to reconstructed jet

$$p_T = p_T^{0-jet} + p_T^{jet-med} + p_T^{background}$$

*0 – jet* jet survives and exits + fragments in the vacuum

*jet – med* jet deposits energy and momentum and excites medium; jet and medium become correlated by had recombination; medium stimulates jet into hard collinear emissions

*background* medium uncorrelated with jet (no intn) but is collected when jet is reconstructed (just by location in angular space)

See for example review by Majumder [arXiv:1405.2019](https://arxiv.org/abs/1405.2019) [nucl-th]

# Answers so far...

- Assume uncorrelated portion is removed (from expt)
- Most current MC event generators

$$p_T = p_T^{0-jet} + p_T^{PART-OF-jet-med}$$

- The other part: out-of-equilibrium deposited E correlated with jet direction
- And then some: E deposited by hard jet in dense medium that flows out of jet cone

See for example review by Majumder [arXiv:1405.2019](https://arxiv.org/abs/1405.2019) [nucl-th]

# Answers so far: MCs

2.76 ATeV PbPb, 0-5% centrality

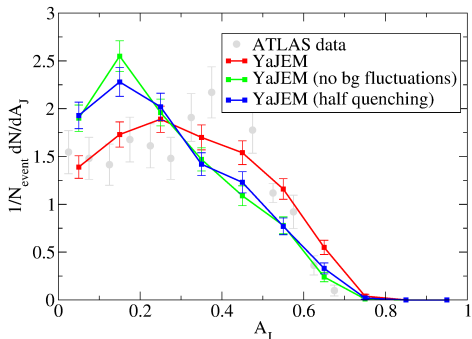

T. Renk (2012)

dijet asymmetry in Pb+Pb ( $\sqrt{s} = 2.76$  ATeV)

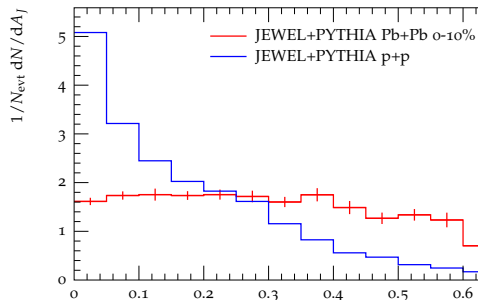

K. Zapp, F. Krauss, U. Wiedemann (2012)

# Answers so far: Eloss and hydro

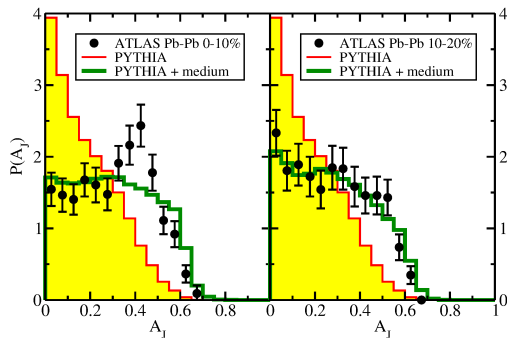

G.-Y. Qin, B. Müller (2012) ↑

T. Tachibana, T. Hirano (2012) →

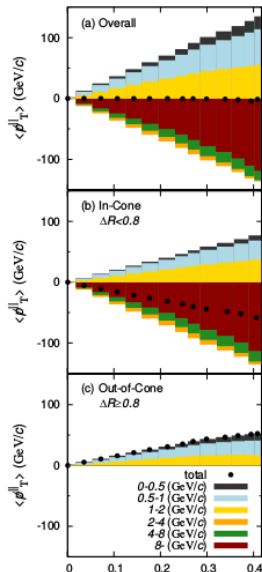

# Our study

We tackle these questions in a scenario that involves some basic ingredients:

- 1 Hard scattered partons that propagate in-medium:  $2 \rightarrow 2$  vs  $2 \rightarrow 3$
- 2 Partons lose avg energy (from linearized hydro with diff. sources)
- 3 Geometry conditions: surface emission
- 4 Hadronization conditions: in vacuum

# Example set up

- ▷ E-loss
  - $\frac{dE}{dx} = 5 \text{ GeV/fm}$
- ▷ E-loss profile: gaussian
  - $\langle \Delta E \rangle = 40 \text{ GeV}; \quad 10 \text{ GeV width}$

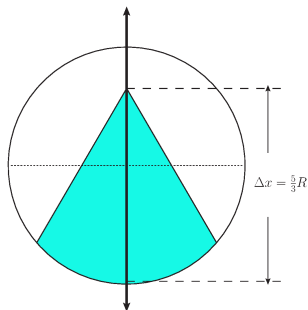

- \* from hydro via: particle mom. dist. from CF

$$\frac{dN}{d\phi} \propto \Delta y \int_{p_T^{\min}}^{p_T^{\max}} \frac{dp_T p_T}{(2\pi)^3} \int d\Sigma_\mu p^\mu e^{-p_T/T_0} \left( \frac{p_T}{T_0} \right) \left( \frac{\delta\epsilon}{4\epsilon_0} + \frac{\mathbf{g}_y \sin \phi + \mathbf{g}_z \cos \phi}{\epsilon_0(1 + c_s^2)} \right)$$

## Sample characterization: pp vs AA

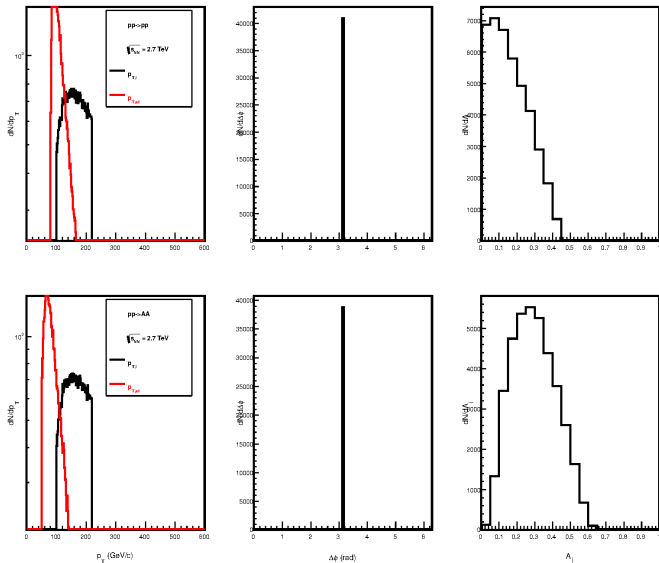

# Sample characterization: ppp vs AAA

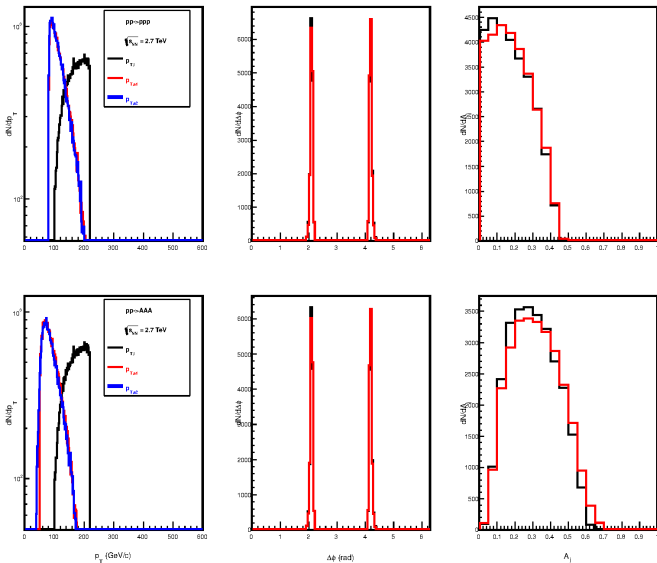

# $A_j$ : 50/50 sample for $2 \rightarrow 2 + 2 \rightarrow 3$

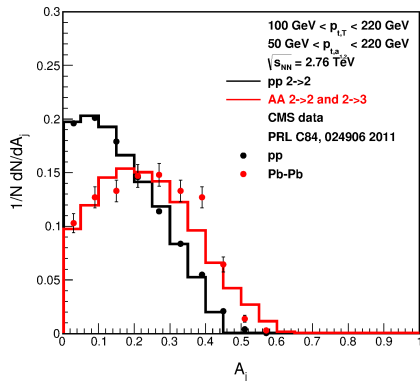
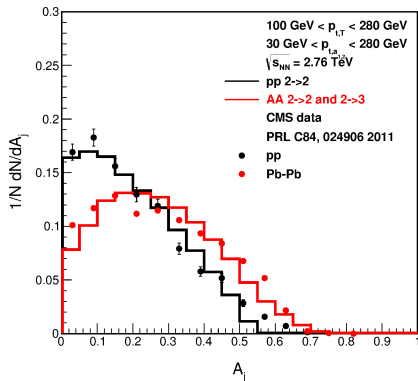

$p_{T,1}^{\parallel}$  in  $pp \rightarrow 2$ :  $100 \text{ GeV} < p_{T,1} < 220 \text{ GeV}$ ,  $50 \text{ GeV} < p_{T,2} < 220 \text{ GeV}$

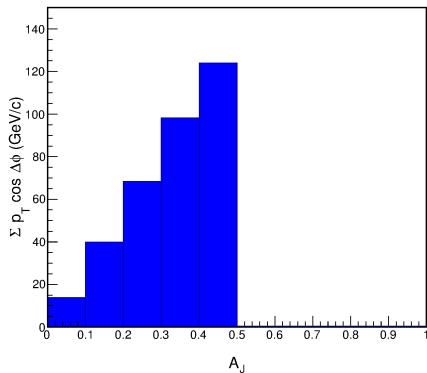
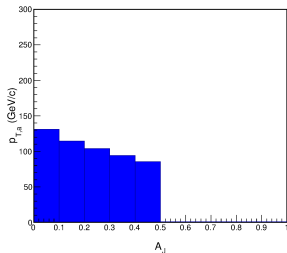
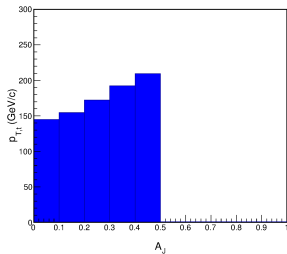

$p_{T,1}^{\parallel}$  in AA  $100 \text{ GeV} < p_{T,1} < 220 \text{ GeV}$ ,  $50 \text{ GeV} < p_{T,2} < 220 \text{ GeV}$

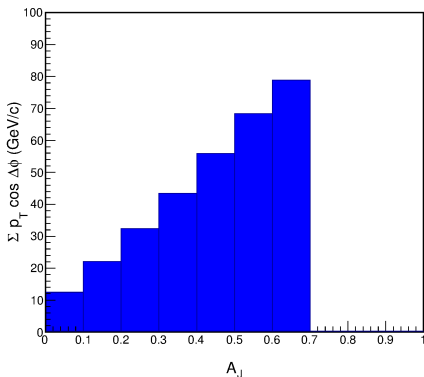

# $A_J$ : 70/30, 90/10 samples

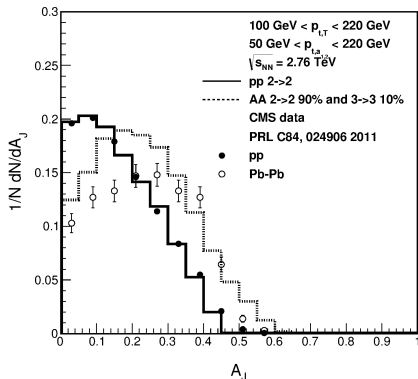
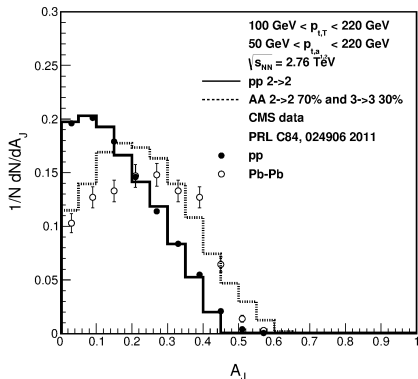

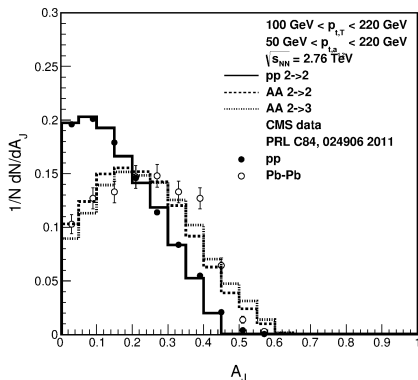
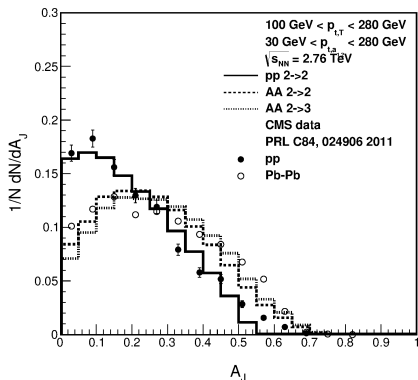
$A_J$ : 50/50 sample,  $2 \rightarrow 2$  vs  $2 \rightarrow 3$ 

# Immediate improvements

- for the initial conditions: instead of localization profile for hard scattering, produce initial condition from saturation (?)
- for the pQCD part:  $2 \rightarrow 2$  vs  $2 \rightarrow 3$   
At the moment people infer this is a dijet shape and the rest is into in/out-of-cone rad. How much of this is  $2 \rightarrow 3$  where smallest away is lost but medium excited by it?
- for the E-loss part: Depending on the interplay between the evolving density of the medium during the collision and the medium size and formation length,  $dE/dx$  can be either constant or proportional to  $L$   
→ use a generalized source (in progress with J. Castaño)

## No conclusions yet: work in progress

Going back to the questions now with 3-prong analysis:

- Overall balance of  $p_T$ : how can we understand the structure of the away side for  $p_T < 8 \text{ GeV}/c$ ?
- Geometry: surface emission vs bulk emission / more asymmetric vs more symmetric
- Energy loss  $\leftrightarrow$  in/out-of cone rad

Expect to have soon:

- characterization of momentum in away side with asymmetry to see effects of E-loss implementation
- connection to other observables such as sphericity ( $\rightarrow$  Isabel)

MANY THANKS