



Development of Data Acquisition System for CALET on the ISS

TADAHISA TAMURA¹, SHOJI TORII², YUKI SHIMIZU², KIN'YA HIBINO¹, SHOJI OKUNO¹, KENJI YOSHIDA³,
HISASHI KITAMURA⁴, YUKIO UCHIHORI⁴, HIROYUKI MURAKAMI⁵

FOR THE CALET COLLABORATION

¹*Faculty of Engineering, Kanagawa University*

²*Research Institute for Science and Engineering, Waseda University*

³*Department of Electronic & Information Systems, Shibaura Institute of Technology*

⁴*National Institute of Radiological Sciences*

⁵*Department of Physics, Rikkyo University*

ttamura@kanagawa-u.ac.jp

Abstract: We have proposed a plan of CALET (CALorimetric Electron Telescope) to Japan Aerospace Exploration Agency (JAXA) to make observations of high energy cosmic rays, electrons, gamma-rays, and nuclei, on the International Space Station (ISS). It has been approved as one of phase-A projects starting in FY2007. The calorimeter (CAL) which is a main instrument of CALET consists of an imaging calorimeter (IMC) and a total absorption calorimeter (TASC). The CAL also has a silicon array (SIA) over the IMC and an anticoincidence detector (ADC) which covers the whole of detector. We will have a preliminary report of the data acquisition system of CALET on the ISS in order to carry out simultaneous observations of electrons, gamma-rays, and nuclein various energy regions.

Introduction

We have proposed CALET (CALorimetric Electron Telescope) to make observations of electrons, gamma-rays, and nuclei on the International Space Station (ISS) [1-3]. CALET has been being developed to have a capability to discriminate incident particles with high accuracy [4]. The calorimeter (CAL) which is a main instrument of CALET consists of an imaging calorimeter (IMC) and a total absorption calorimeter (TASC).

Instrumentation

The IMC comprises 18 layers of scintillating fibers (SCIFIs) which are inserted between tungsten plates. Each layer of SCIFI is composed of x- and y-direction belts. One belt is made of 896 SCIFI of 1 mm square in cross section and has a width of 896 mm. The fluorescence from SCIFI is read out with 64 anodes photo-multiplier tubes (MAPMTs). Each SCIFI corresponds to one anode of MAPMT. Therefore, we need to read out

32256 channels of 504 MAPMTs in total for the IMC. Silicon arrays (SIA) are to be set on the top of the IMC to determine the charge of the incident particle precisely [5].

The TASC is made of 12 layers of BGO. One layer includes 48 logs of BGO. The fluorescence from each BGO log is to be read out with one photo-multiplier tube (PMT) or three photodiodes (PDs) in one package. We are now investigating which sensor is better to read out BGO signals extending over 6 orders of magnitude. Whichever sensor we choose, at least 3 channels of readout circuit in different gain are necessary for one BGO log to cover its dynamic range. In total, readout circuits of 1728 channels are used for the TASC.

An anti-coincidence detector (ACD) covers the CAL to reject charged particles. It is necessary for the observation of gamma-rays below 10 GeV. A signal from the ACD is not included in a trigger condition for the observation of gamma-rays over 10 GeV. Otherwise back-scattered particles from shower induced by incident gamma-ray will activate the ACD to reject the event. The ACD is

composed of plastic scintillators of 1 cm thickness segmented into 85 tiles. Wave length shifter fibers are buried in each tile of plastic scintillator, and are read out by 2 PMTs. We use 170 PMTs in total to read out the ACD. Detectors and sensors of CAL are summarized in Table 1.

Table1: Characteristics of CAL (Preliminary)

CAL	Detector Material + Sensor	Power [W]	Data [kbps]
IMC	SCIFI + MAPMT	200	150
TASC	BGO + (PMT or Triple-PD)	60	50
SIA	Silicon Pixel	120	30
ACD	Plastic Scintillator + PMT	15	20
Total		395	250

Electronics

Front-end Circuit

Figure 1 shows a configuration of the IMC. The MAPMTs are attached to the SCIFIs at the end of the SCIFI belts. The FECs are installed just behind the MAPMTs. We have developed an analog ASIC, VA32HDR14, that is optimized for the readout of the MAPMT. Each FEC includes a 16 bits ADC and FPGA for data process control.

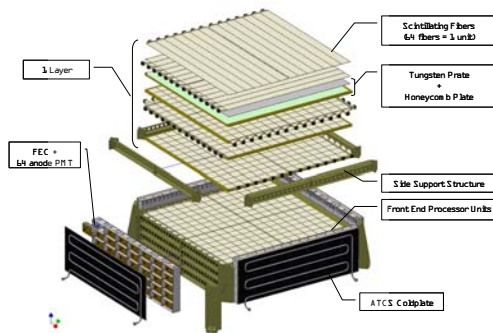

Figure 1: Schematic structure of IMC

Figure 2 shows a quarter of the TASC structure. A triple-PD package or a PMT is attached to one BGO log at its end. The FEC units to read out the PDs or the PMTs are set around the TASC. Development of the FEC for TASC will be reported

in detail at the other pages in this proceedings by Y. Katayose [6].

Estimated power consumption and data rate are listed in the Table 1. The estimated values are just preliminary.

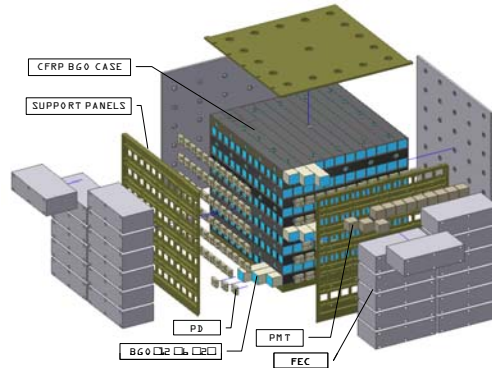

Figure 2: Schematic structure of a quarter of TASC

Data Acquisition System

The electronics system of CALET can play a role to take data from the detectors and to send them to the JEM-EF system via a data processor, DP. Commands are received also through the DP. The power is supplied from a standard utility unit of JEM-EF, Power Distribution unit of Attached Payload (PDAP). A block diagram of the electronics system is presented in Fig. 3. The PDAP transforms the standard power of 120 V on the JEM-EF to 28 V. The data acquisition (DAQ) transforms the power of 28 V to several adequate voltages and redistributes the secondary power to electronics system of CALET.

The FEC on each detector starts to make an event-data ready by receiving a trigger signal generated by the TRG. When the event data get ready in FECs of all detectors, the DAQ begins to acquire data from the FECs.

As support sensors, CALET has a GPS, the temperature sensors, and a visual star camera (VSC) to get a precise attitude.

A gamma-ray burst monitor (GBM) is to be installed on CALET [7]. Once a gamma-ray burst is detected, the DAQ starts the gamma-ray data taking all the energy range of the CAL.

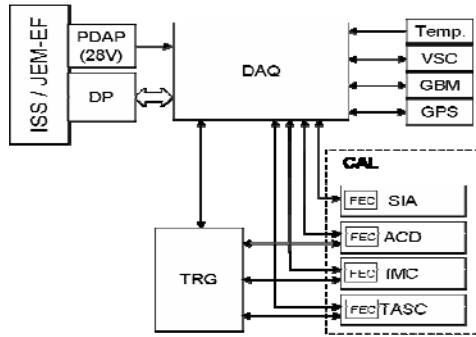

Figure 3: Block diagram of electronics system.

The DAQ has four kinds of interfaces to the DP as shown in Fig. 4. The DAQ receives commands and timing information from the DP through one of the interface. Synchronous clock is supplied to the DAQ from the DP through another interface. Event and monitor data to be sent by telemetry are transferred to the DP from the DAQ through the other interface. Periodical house keeping data are sent via the rest interface from the DAQ to the DP.

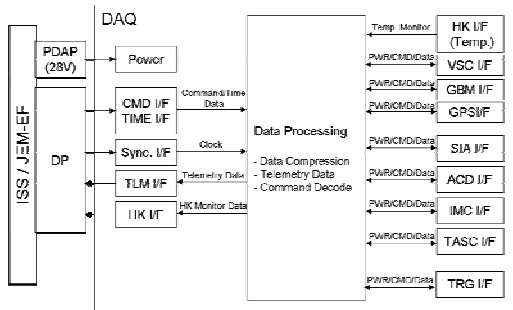

Figure 4: Block diagram of DAQ.

A data processing unit in the DAQ performs compression of data acquired from the detectors and the other sensors. It builds packages of data in a telemetry format, and decodes the commands to change some conditions. It sends appropriate commands to FECs of the detectors or the TRG unit. For example, a scheduling of the trigger mode setting or energy threshold level for the trigger can be changed by the commands. The DAQ also distributes the secondary power to the detectors and the other units.

Trigger Mode

Triggers are to be generated by combining the information from the IMC, the TASC and the ACD. We will adopt three trigger modes. ‘Shower’ trigger will be generated if shower energy over 10 GeV is detected by the IMC and the TASC. ‘Low energy gamma-ray’ trigger will be generated if a track is detected in the IMC and no signal is detected in the ACD. ‘Low energy electron’ trigger will be generated if shower energy between 1 GeV and 10 GeV is detected by the IMC and the TASC. Combination of these trigger modes are used for CALET observation according to several situations.

Shower Trigger

The observation of electrons up to the highest energy range, ~10 TeV, is one of the most important objectives of CALET. In order to detect electrons effectively against background protons, we use a method of shower trigger which had been well established in BETS and PPB-BETS experiments [8,9].

For the shower trigger, development of a cascade is measured at each layer of the IMC and the TASC. It is essential to the shower trigger that almost all electromagnetic showers should start development before a depth of a few radiation lengths. The TRG discriminates the shower development measured by the IMC and the TASC, and issues a trigger if the shower development is recognized to be electron-like and more than 10 GeV. Gamma-rays over 10 GeV can be detected with the shower trigger because the gamma-rays can make an anti-coincidence signal due to the back-scattered particles.

Showers induced by nuclei generally starts at deeper part than electromagnetic showers. Therefore, the background protons are effectively eliminated by the shower trigger. Showers induced by high energy nuclei cause a lot of back-scattered particles, and the shower trigger might be issued in 1 TeV to 1000 TeV even if the starting points are deep.

We roughly estimate a trigger rate of the shower trigger to be about 30 Hz from simulations and a previous balloon experiment [10]. Most of the shower triggers can be caused by background protons.

Low Energy Gamma-ray Trigger

Gamma-rays over about 1 GeV induce electromagnetic showers. At lower energies, however, we could detect an electron-positron pair created by the gamma-rays. Effective detection of tracks caused by gamma-rays is very difficult if background charged particles are not rejected with the ACD. The low energy gamma-ray trigger will be generated if a track is detected at more than 3 layers of SCIFI and no hit exists on the ACD. A rate of the low energy gamma-ray trigger is estimated to be about 45 Hz.

Low Energy Electron Trigger

Electron observations below 10 GeV is important to study the solar activity [3]. We have a plan to make low energy electron observations near the north and south poles where the cutoff rigidity is less than 10 GV. The trigger is performed by shower trigger adopted to electrons over 1 GeV. This trigger mode is used only near the north and south poles. The estimated observation time is 2.8 % of the total. Outline of the trigger modes are summarized in Table 2.

Table2: Estimated Trigger mode and rate

Trigger mode (Energy Range)	Object	Trigger Rate [Hz]
Shower (>10 GeV)	Electron, Gamma- ray, Nuclei	30
Low energy Gamma-ray (20 MeV – 10 GeV)	Gamma-ray	45
Low energy Elec- tron (1 GeV – 10 GeV)	Electron	100

Summary

The detector system of CALET has been designed on the basis of technologies established in previous balloon payload for the electron and gamma-ray observations. We have been developing the FECs for the IMC and the TASC. The data acquisition system will be considered more definitely in the phase-A starting in FY2007. The triggers will be generated by the TRG unit with

signals from the IMC, TASC, and ACD. Observations of electrons, gamma-rays, and nuclei will be made simultaneously by the combination of three kinds of trigger. We have already made a balloon experiment with a 1/64 scale model and have verified the electronics system and the detector performance.

References

- [1] S. Torii et al., OG.1.5 in this proceedings.
- [2] K. Yoshida et al., HE.3.5 in this proceedings.
- [3] Y. Komori et al., SH.3.1 in this proceedings.
- [4] K. Kasahara et al., OG.2.7 in this proceedings.
- [5] P. S. Marrocchesi et al., OG.1.5 in this proceedings.
- [6] Y. Katayose et al., OG.1.5 in this proceedings.
- [7] K. Yamaoka et al., OG.2.7 in this proceedings.
- [8] S.Torii et al., NIM A 452 (2000) 81.
- [9] S.Torii et al. , ASR 37 (2006) 2095.
- [10] Y. Shimizu et al., OG.1.5 in this proceedings.