

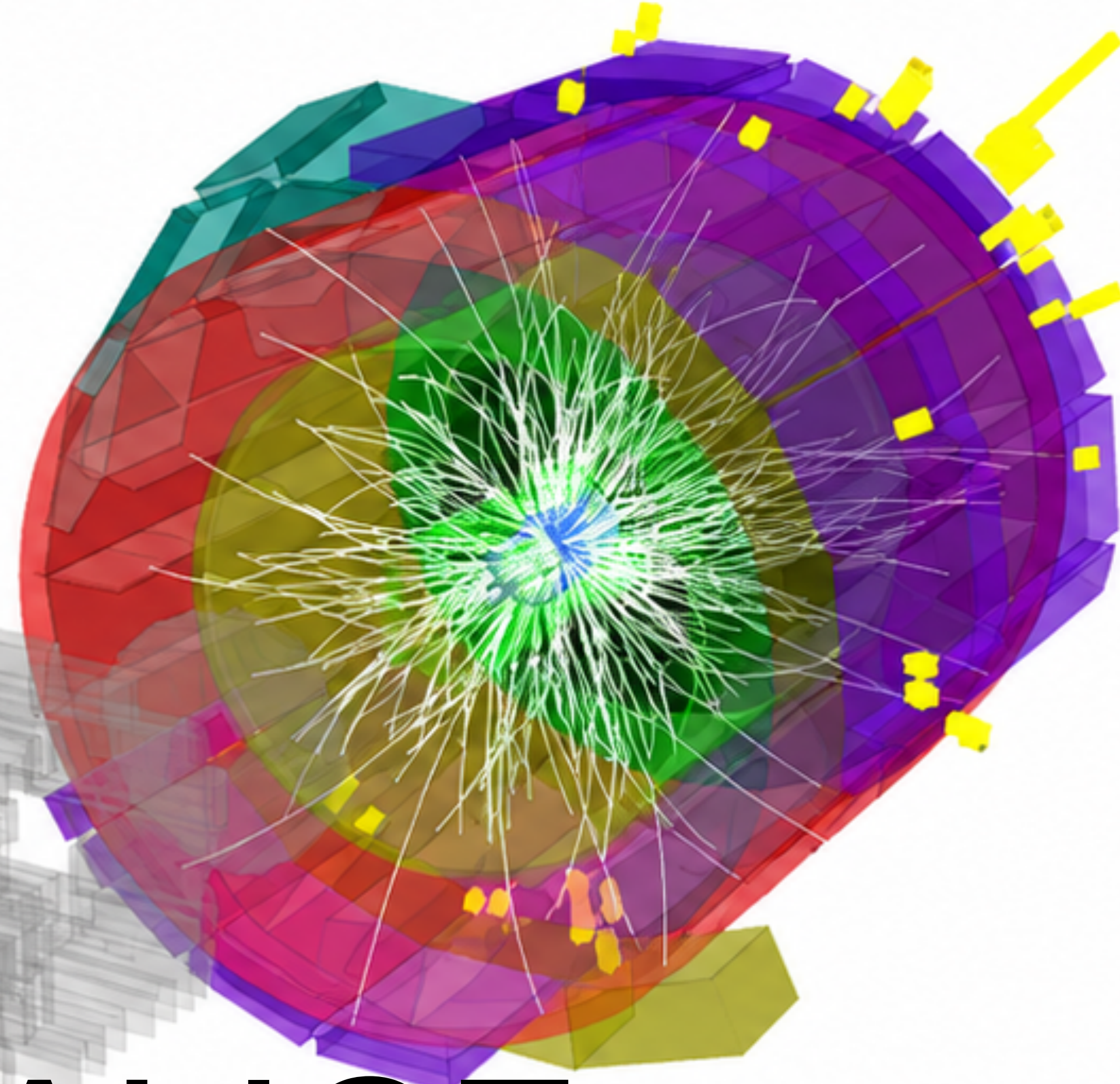

XL

Annual Meeting
of the Division of
Particles and Fields



ALICE overview

Antonio Ortiz



Instituto de
Ciencias
Nucleares
UNAM

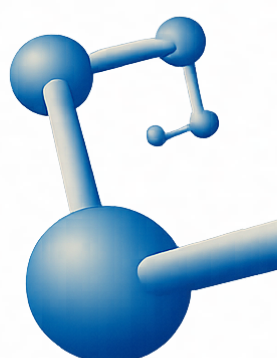

475+
UNIVERSIDAD
1331 MÉXICO 2026

Mexico City / June 17, 2026

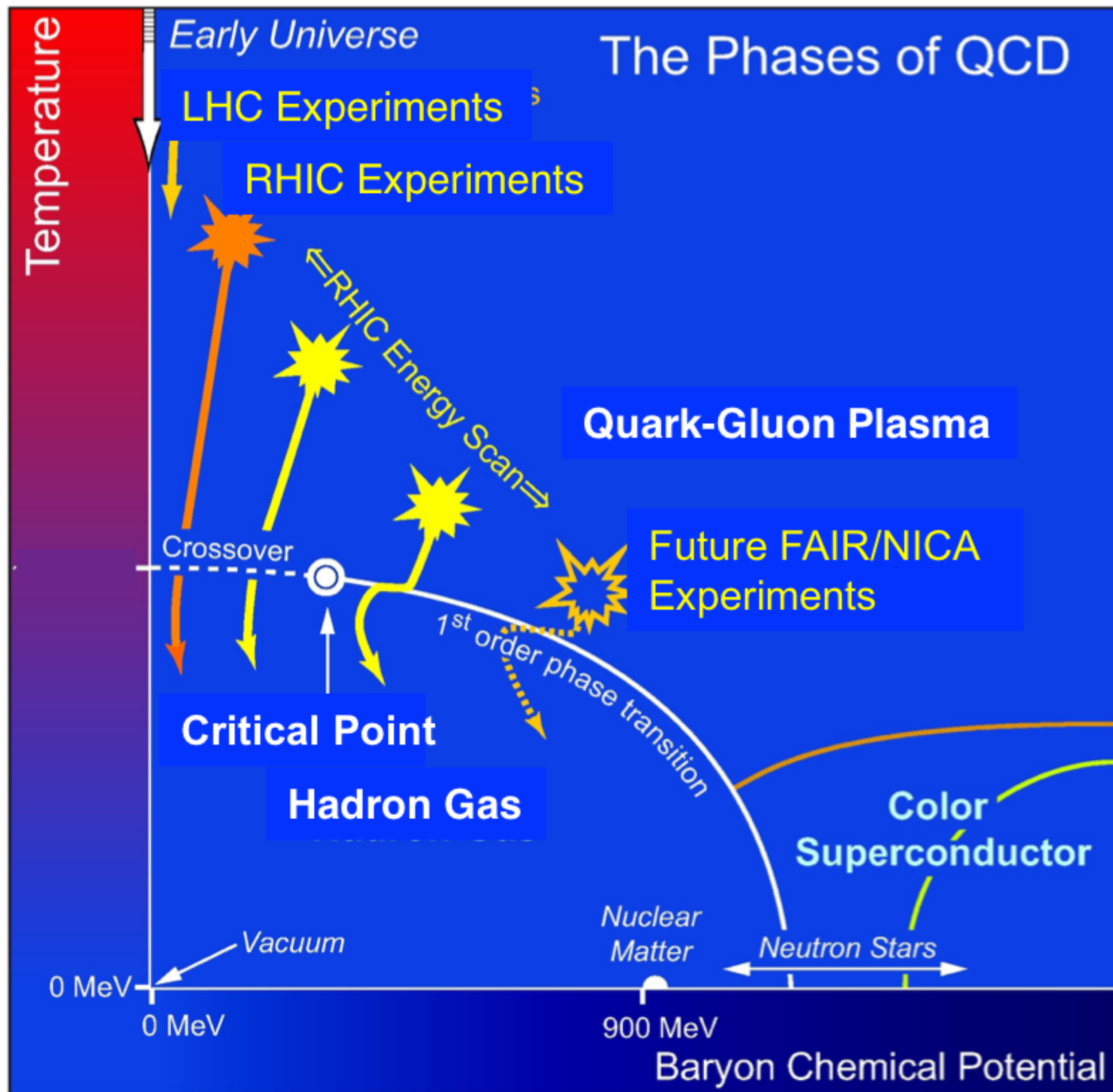

Tapan K. Nayak 2020 *J. Phys.: Conf. Ser.* **1602** 012003

QCD laboratory!

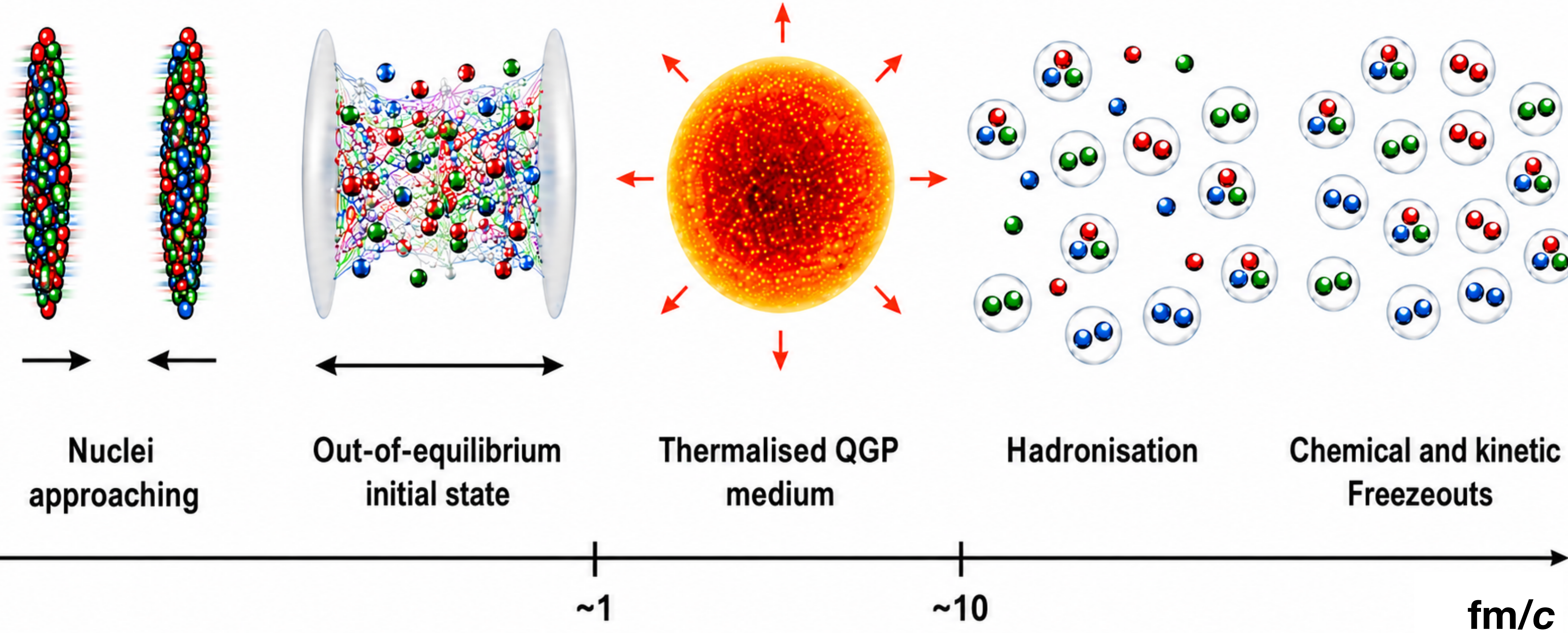

ALICE (A Large Ion Collider Experiment)

37 countries, 165 institutes, 1912 members

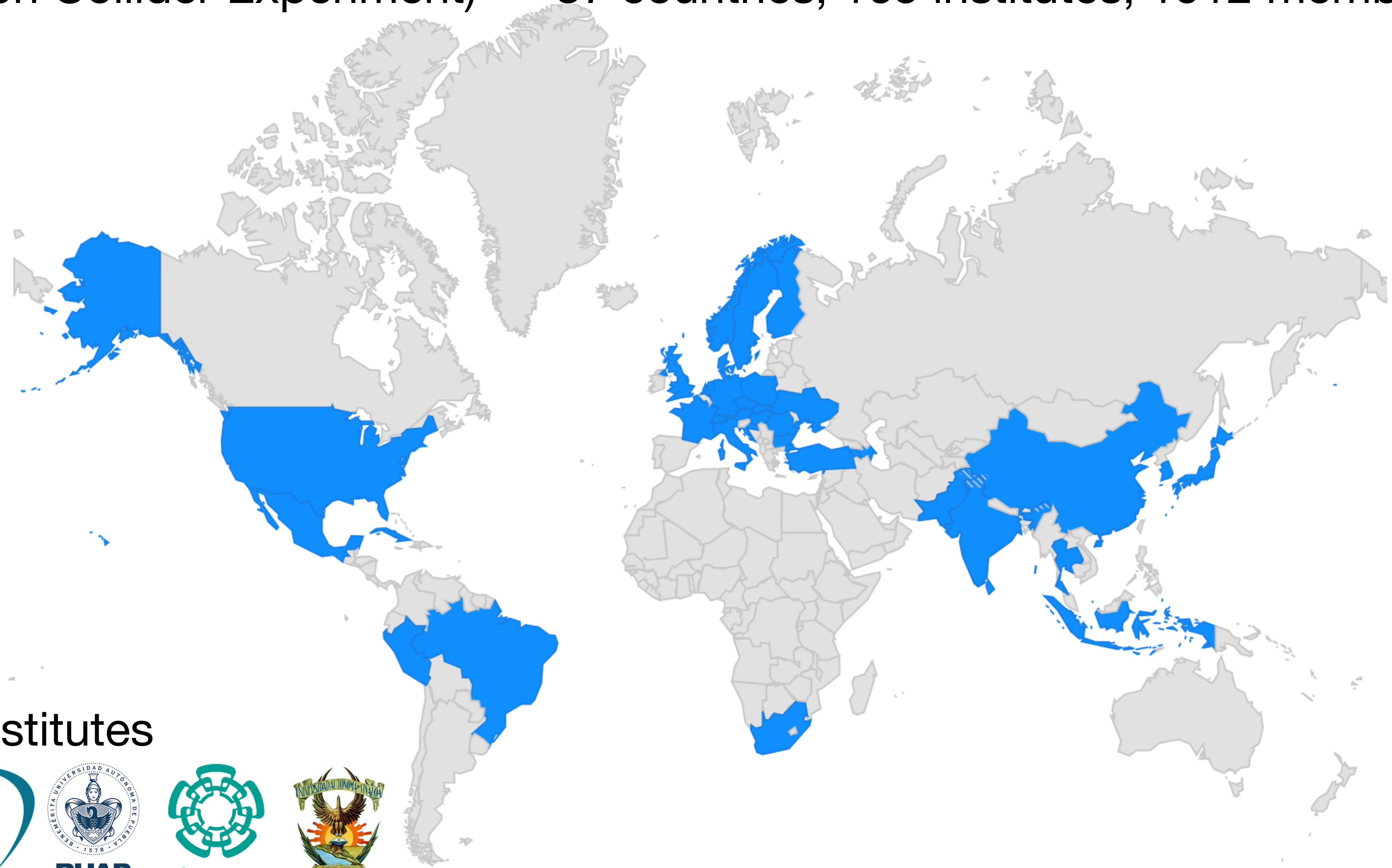

Mexico:

48 members, 5 institutes





The ALICE experiment: A journey through QCD

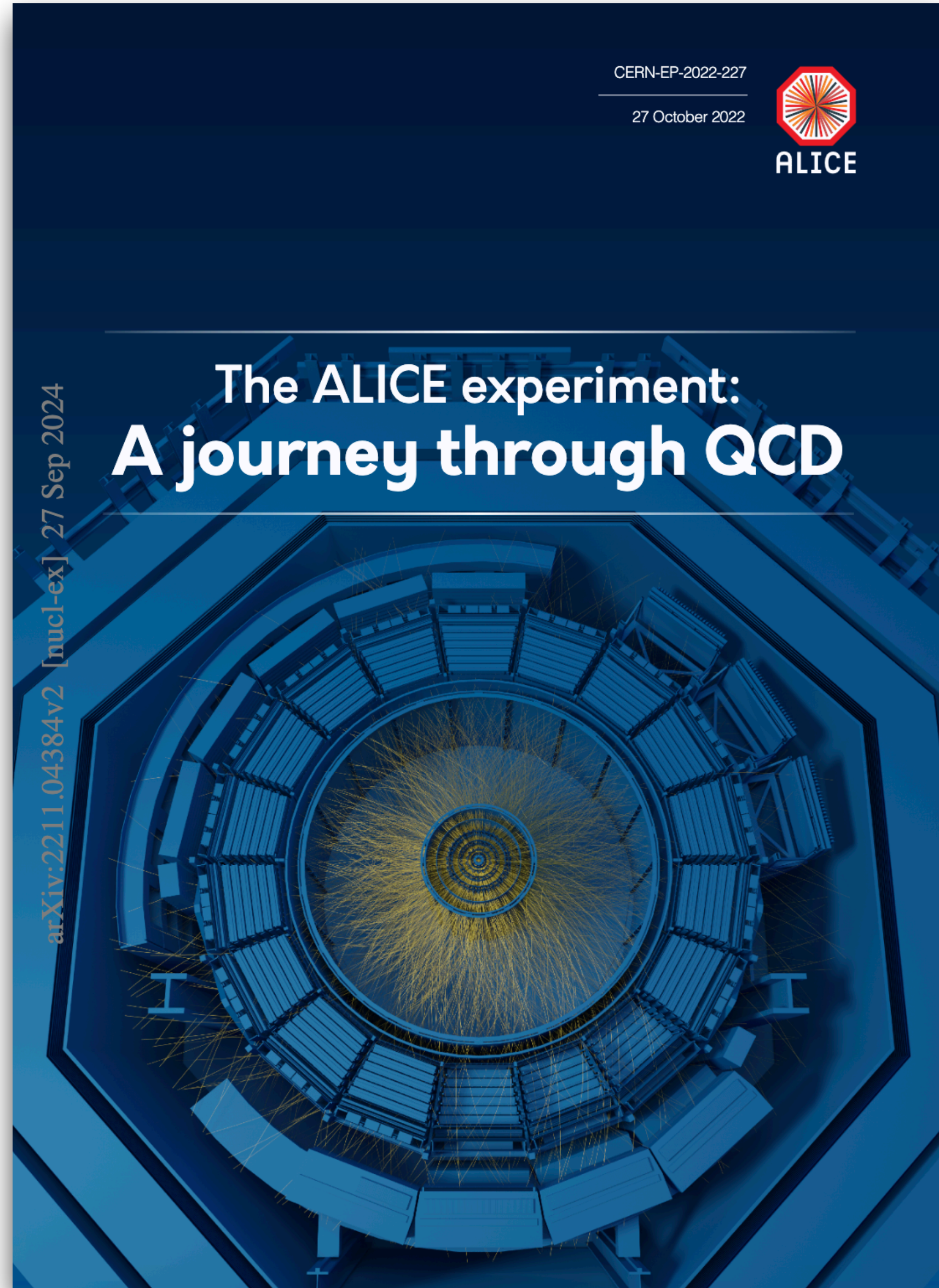

arXiv:2211.04384v2 [nucl-ex] 27 Sep 2024

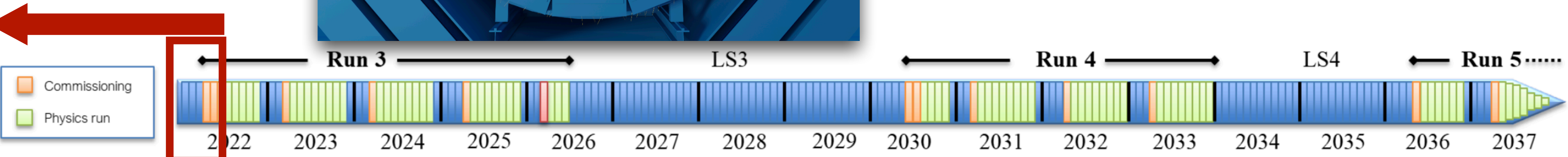
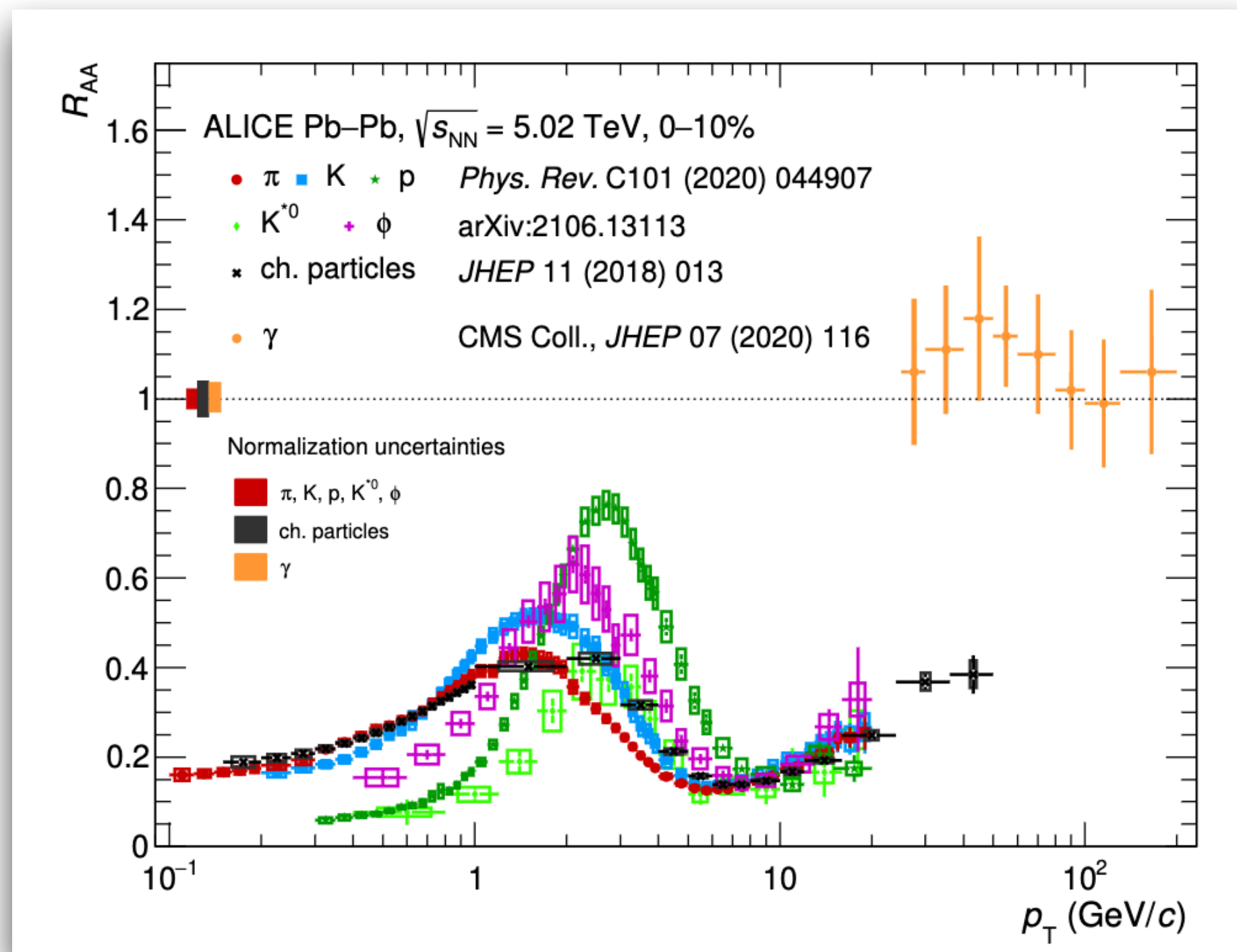

ALICE in Run 3

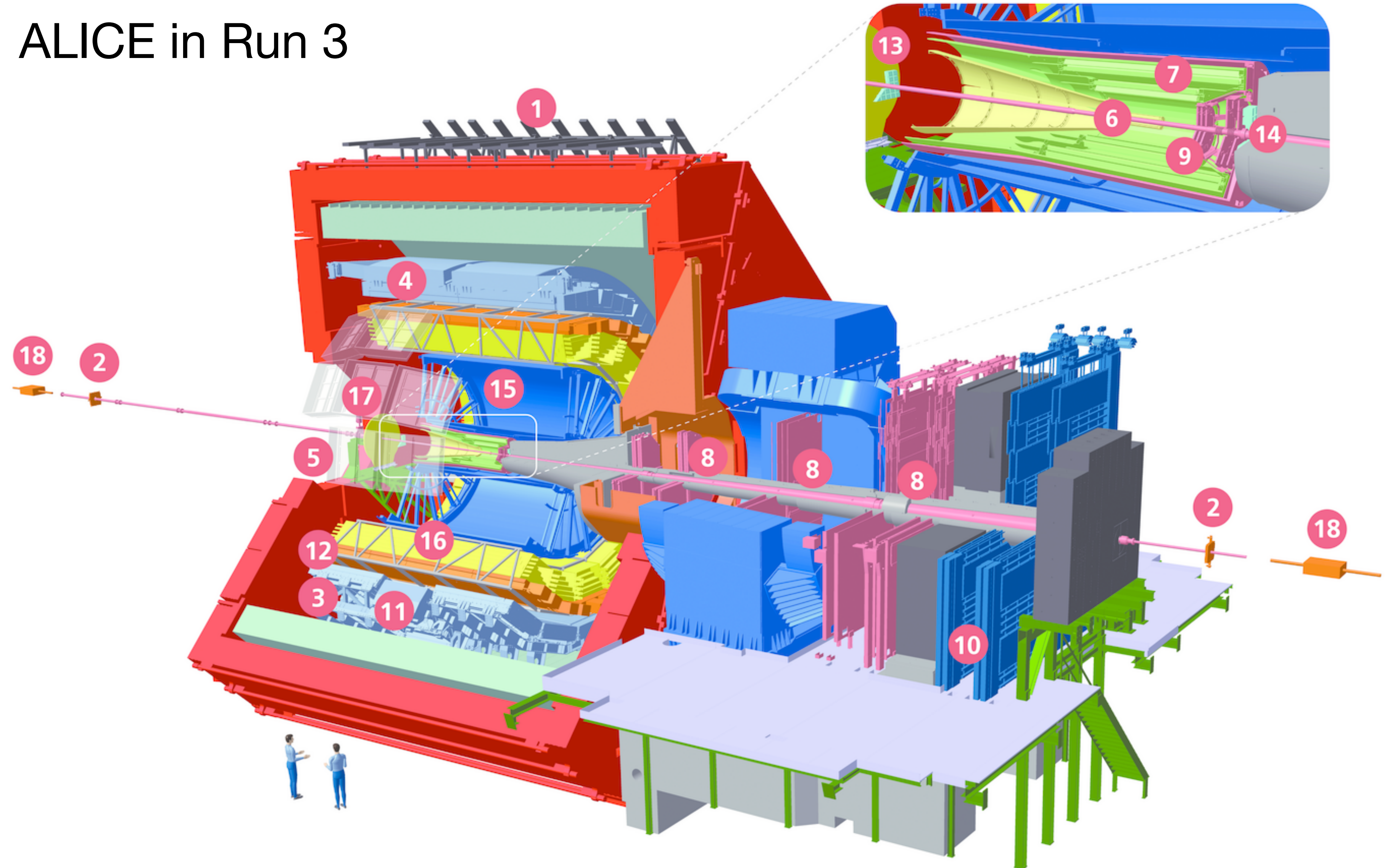

- 1 ACORDE | ALICE Cosmic Rays Detector
- 2 AD | ALICE Diffractive Detector
- 3 DCal | Di-jet Calorimeter
- 4 EMCal | Electromagnetic Calorimeter
- 5 HMPID | High Momentum Particle Identification Detector
- 6 ITS-IB | Inner Tracking System - Inner Barrel
- 7 ITS-OB | Inner Tracking System - Outer Barrel
- 8 MCH | Muon Tracking Chambers
- 9 MFT | Muon Forward Tracker
- 10 MID | Muon Identifier
- 11 PHOS / CPV | Photon Spectrometer
- 12 TOF | Time Of Flight
- 13 T0+A | Tzero + A
- 14 T0+C | Tzero + C
- 15 TPC | Time Projection Chamber
- 16 TRD | Transition Radiation Detector
- 17 V0+ | Vzero + Detector
- 18 ZDC | Zero Degree Calorimeter

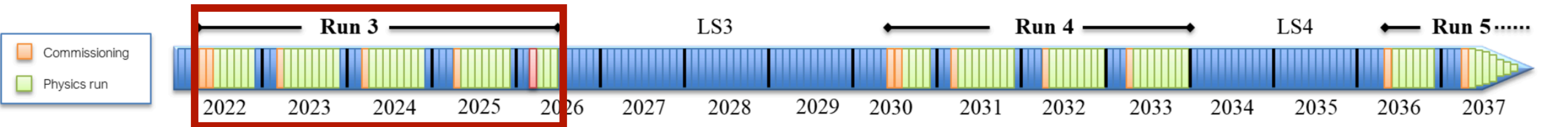

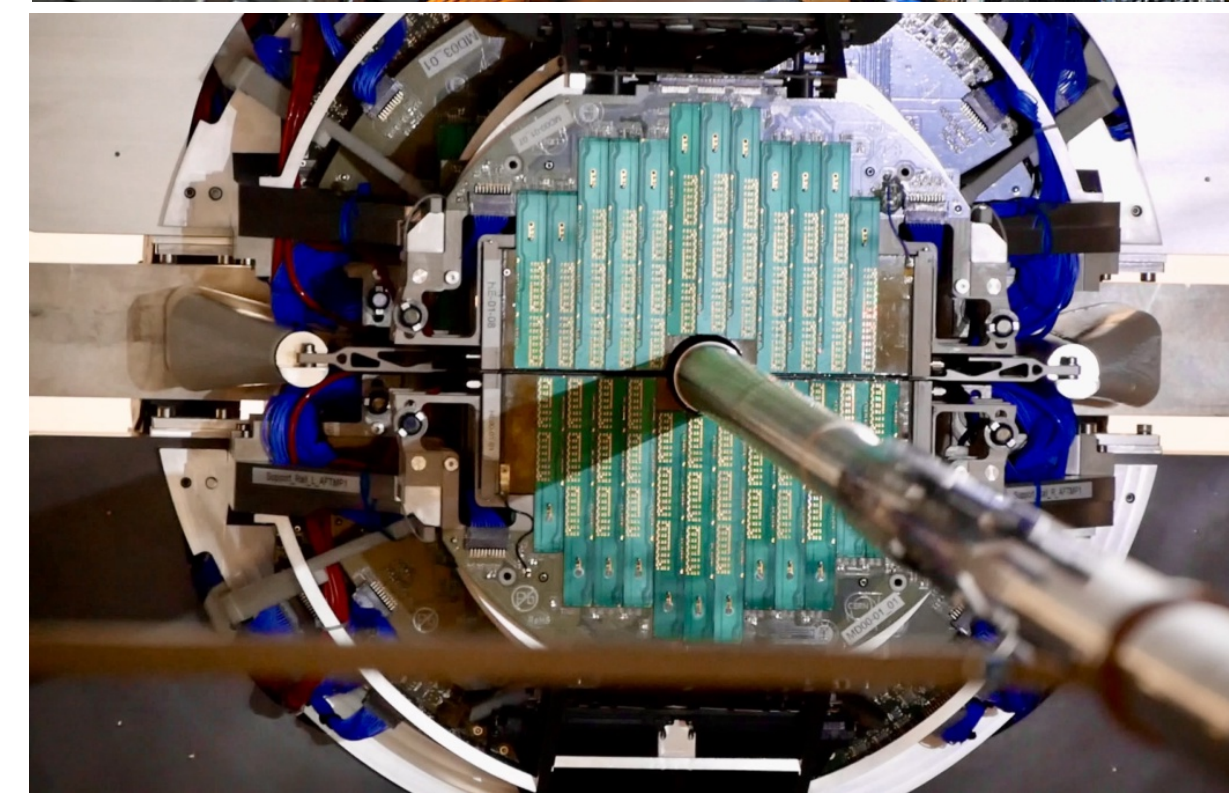
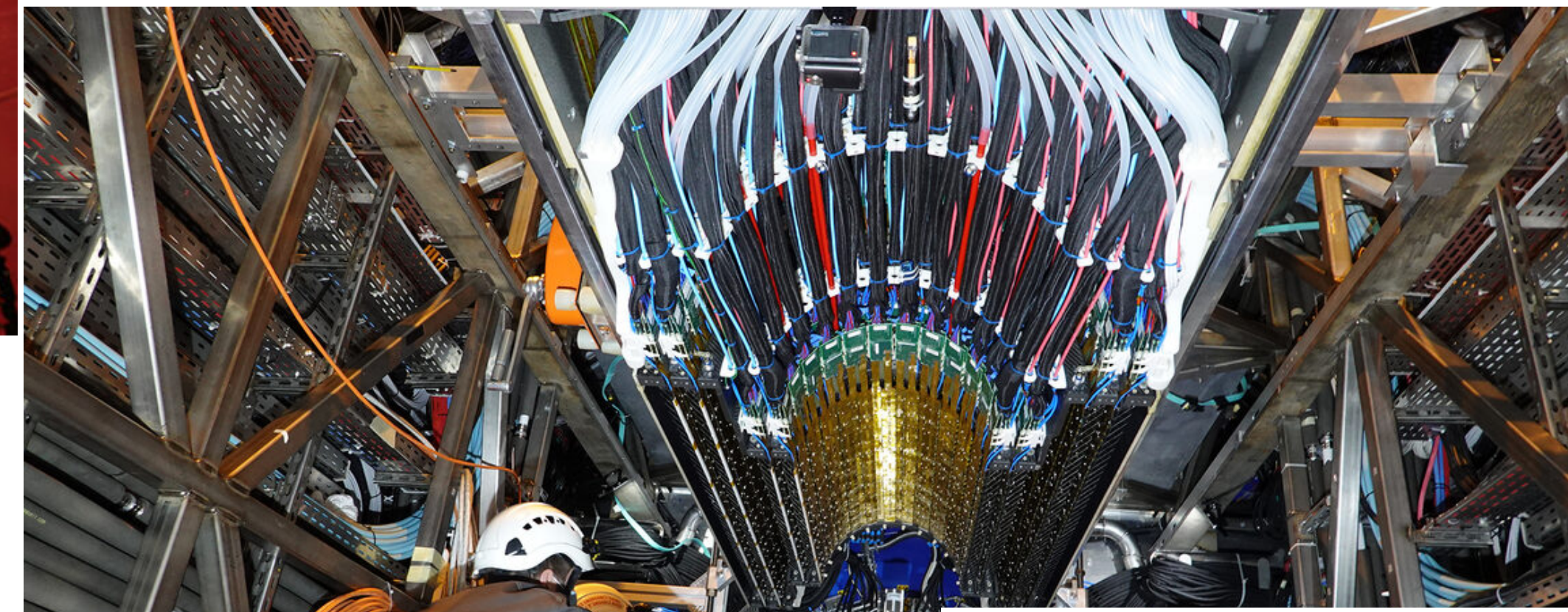
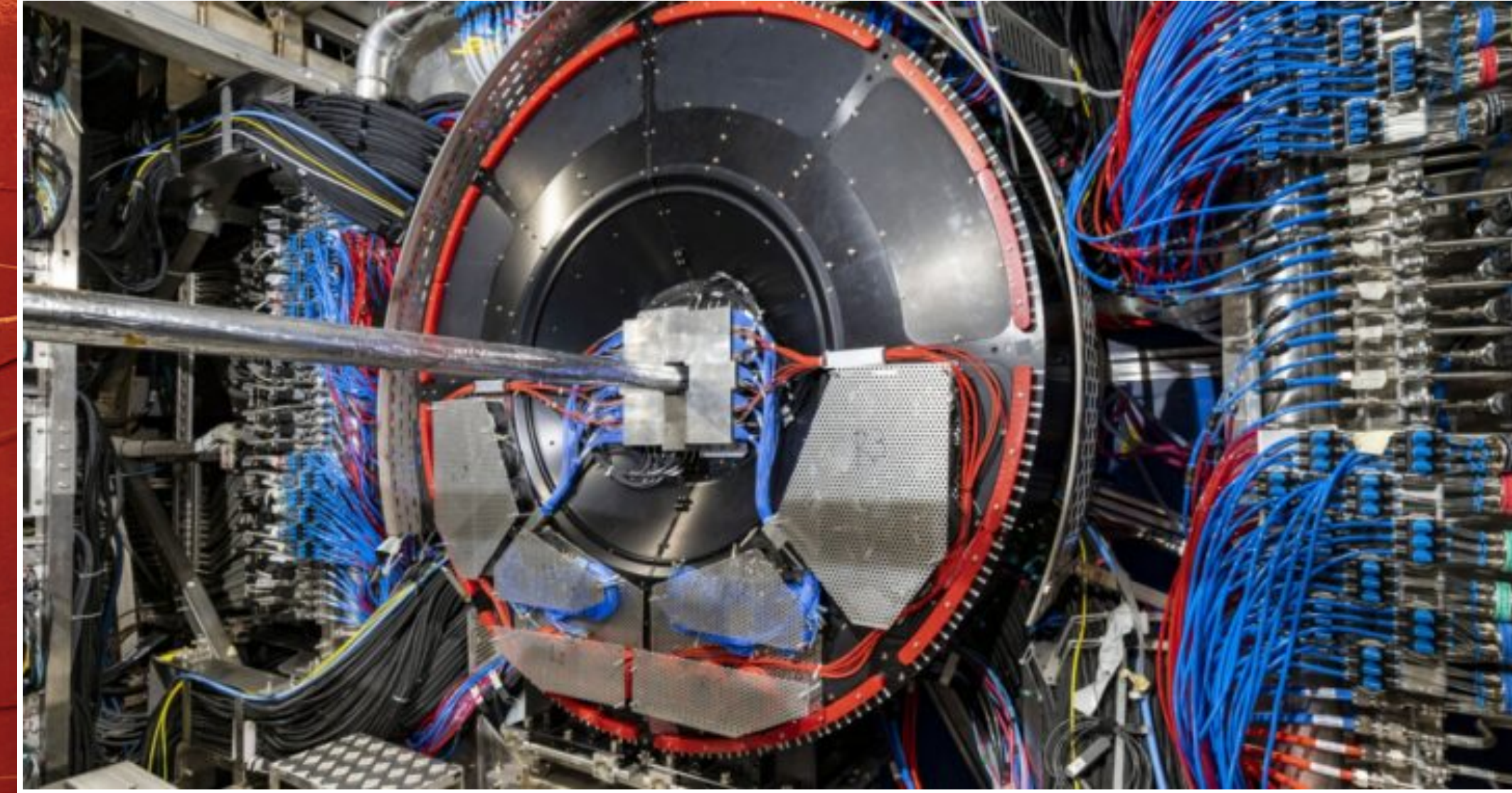
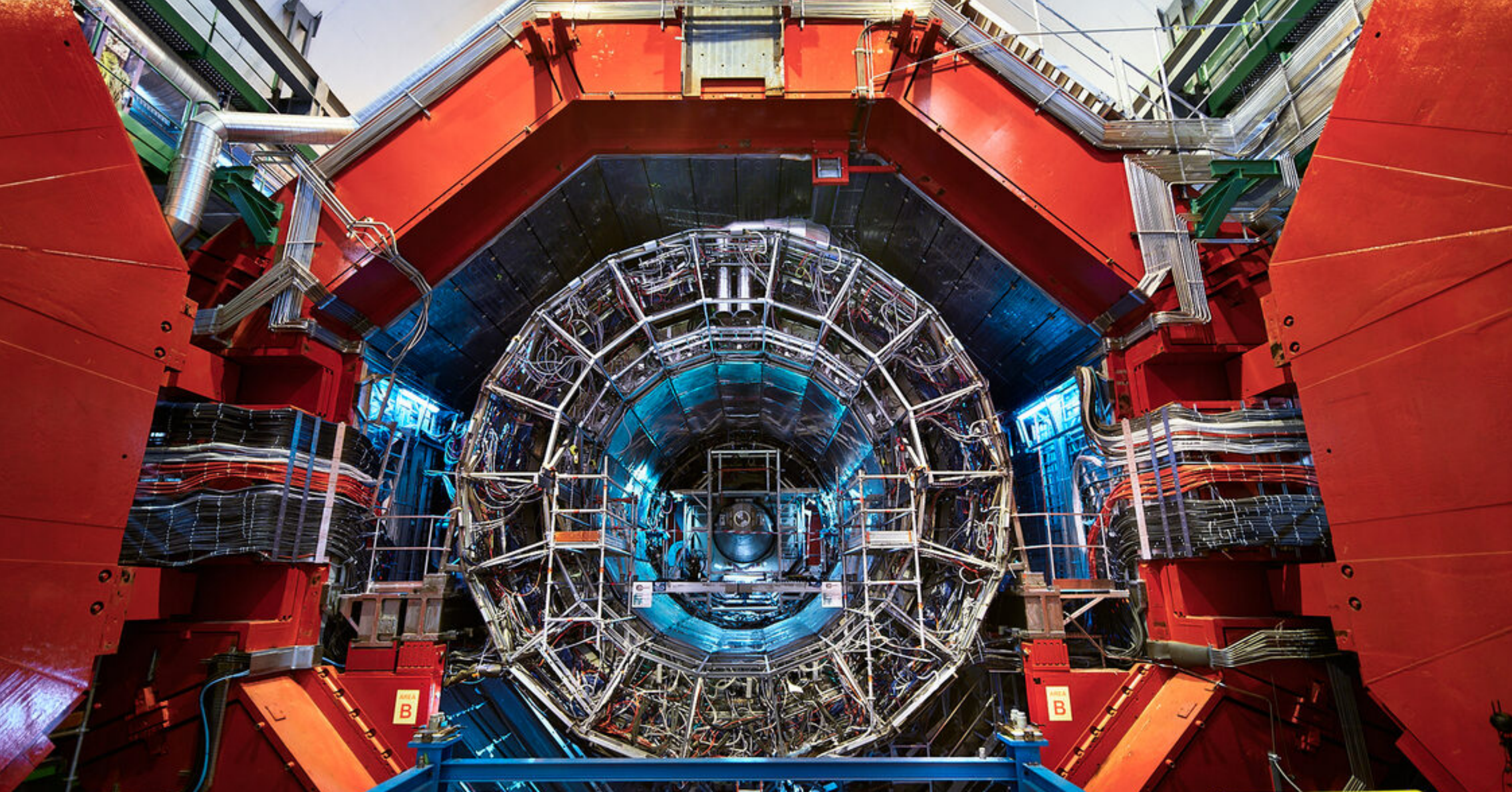

LHC Run 3 (2022-2026)

- New Inner tracking system (7 layers of MAPS detectors)
- TPC GEM readout chambers for continuous readout
- Cherenkov and scintillator arrays for interaction time
- Muon tracking system at forward rapidity
- Advanced GPU farm for data processing and reconstruction

- $\sim 8 \times 10^{12}$ MB pp events (**x1000 more than Runs 1+2**)
- $\sim 6.5 \times 10^9$ MB OO events
- $\sim 50 \times 10^9$ MB Pb-Pb events (**x120 more MB than Runs 1+2, x20 more central than Runs 1+2**)

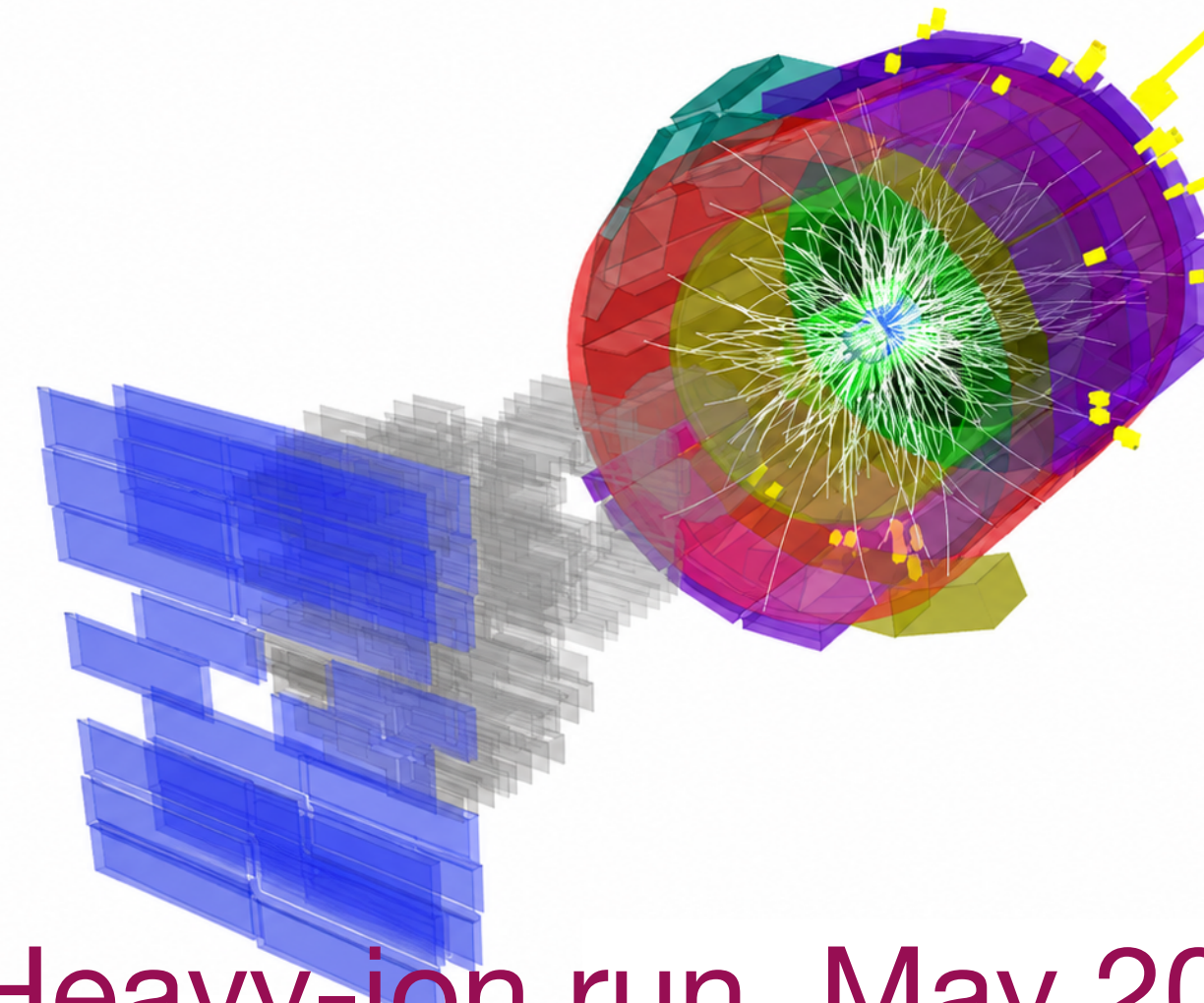

Heavy-ion run, May 2026

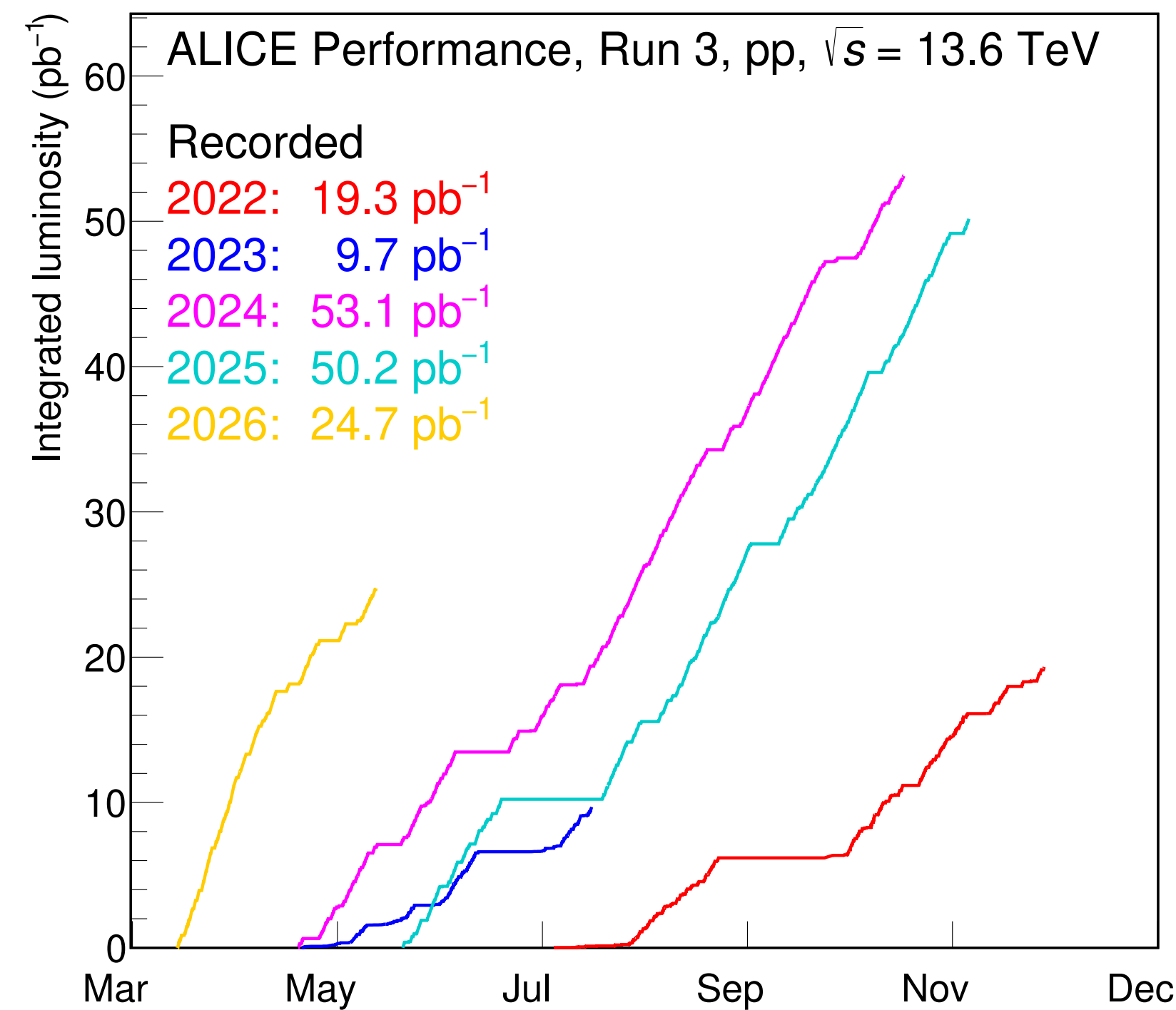

ALI-PERF-630176

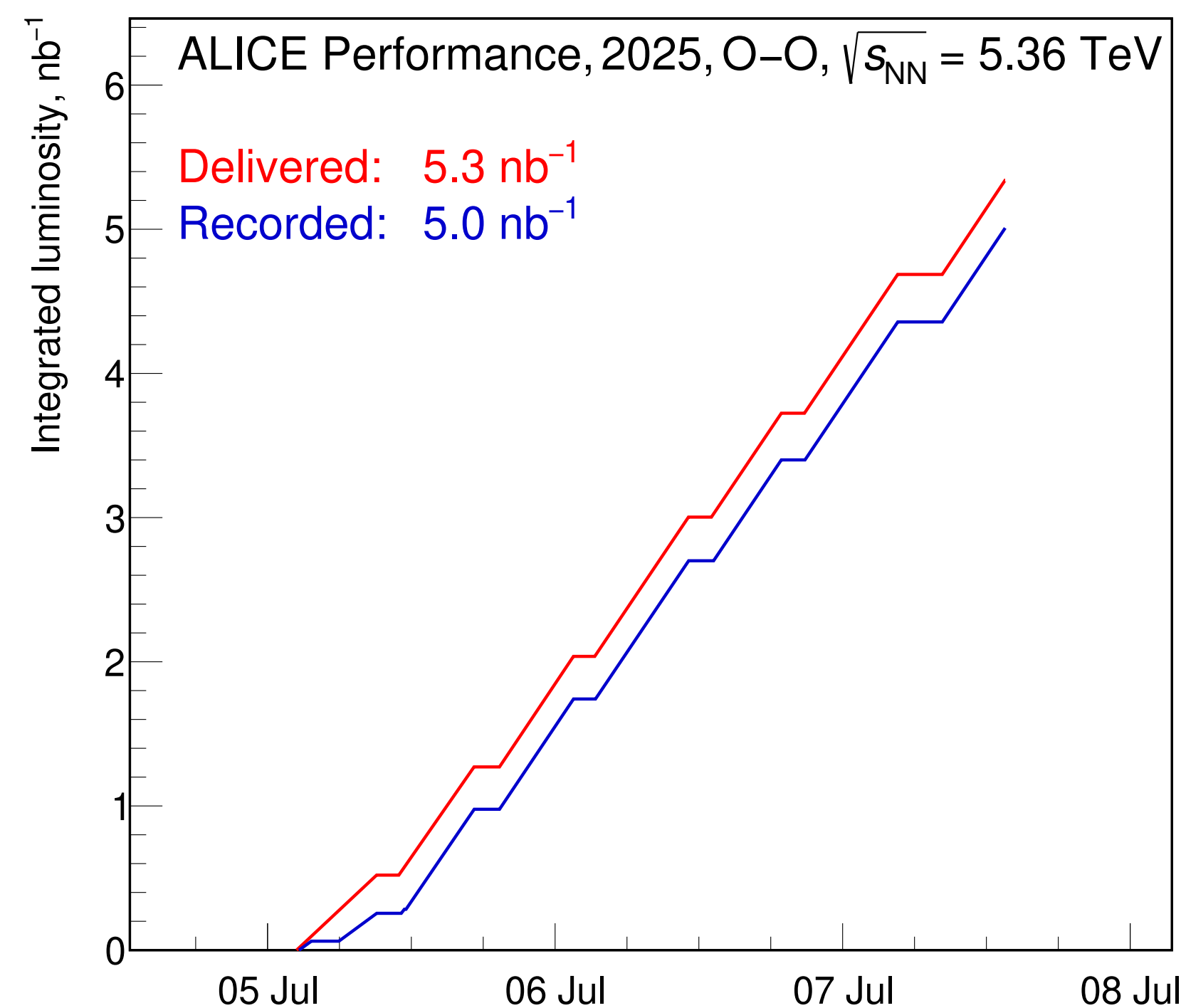

ALI-PERF-608698

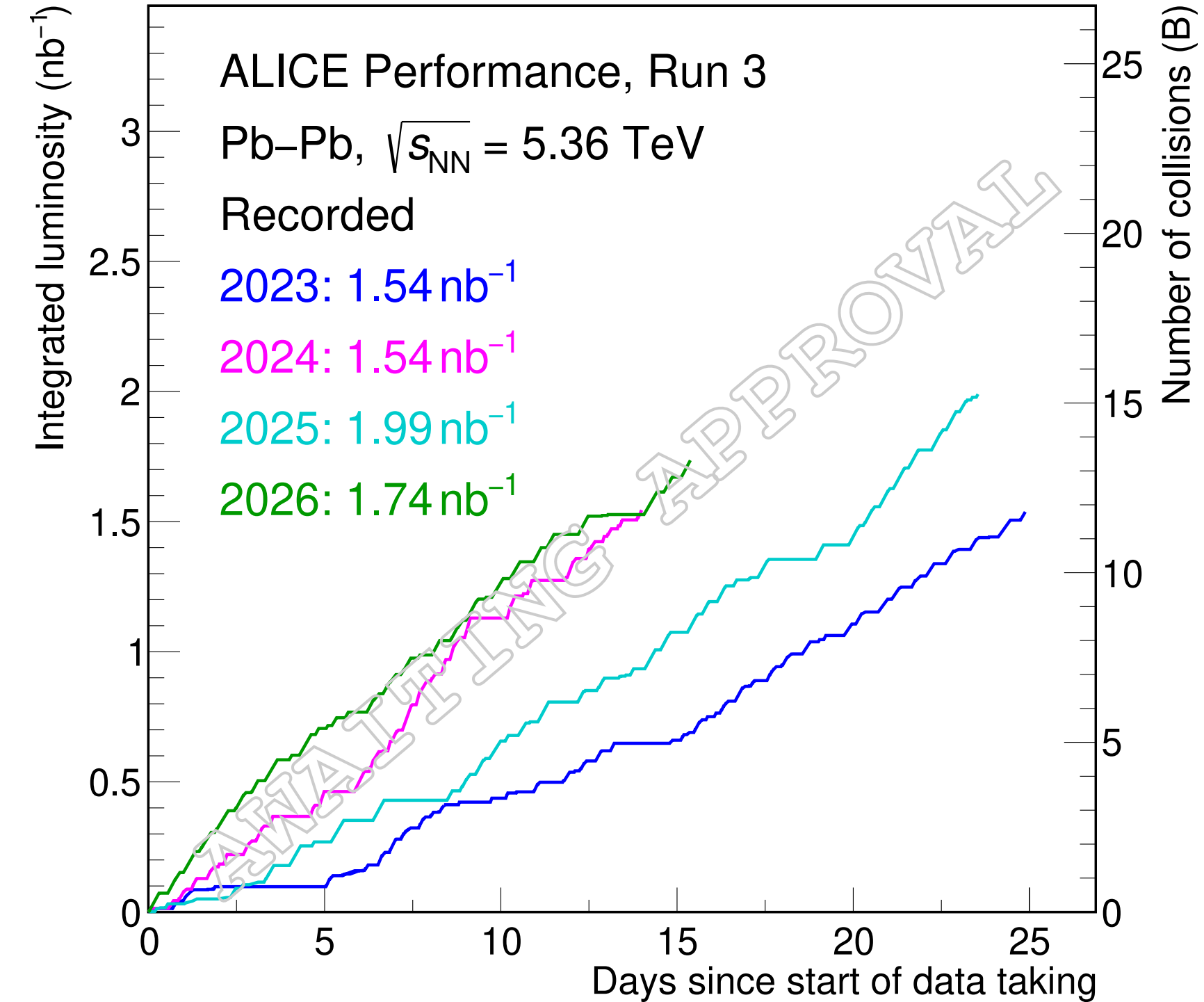

ALI-PERF-634120

Upgraded ALICE detector achieves excellent precision down to p_T of 0 GeV/c

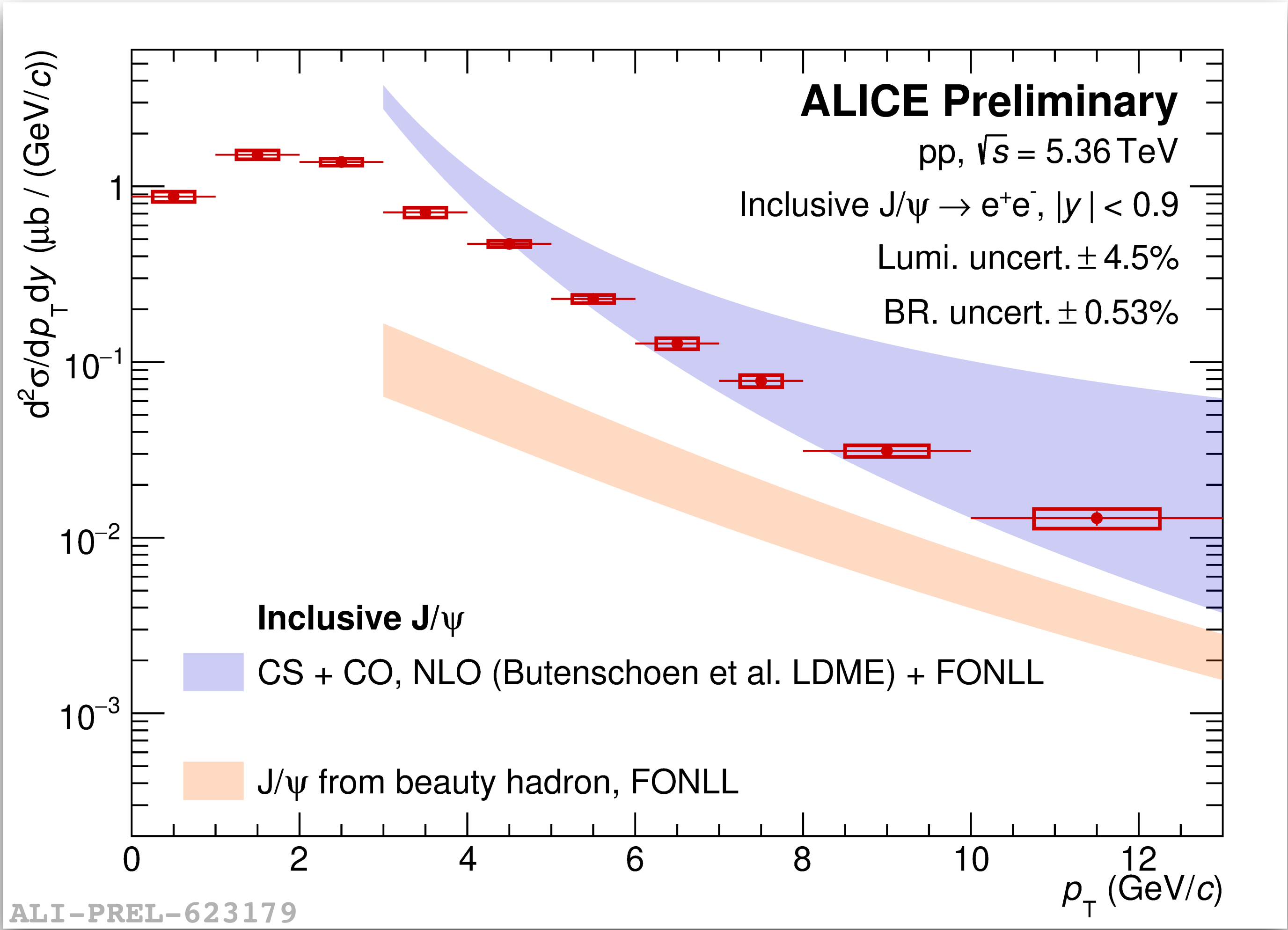
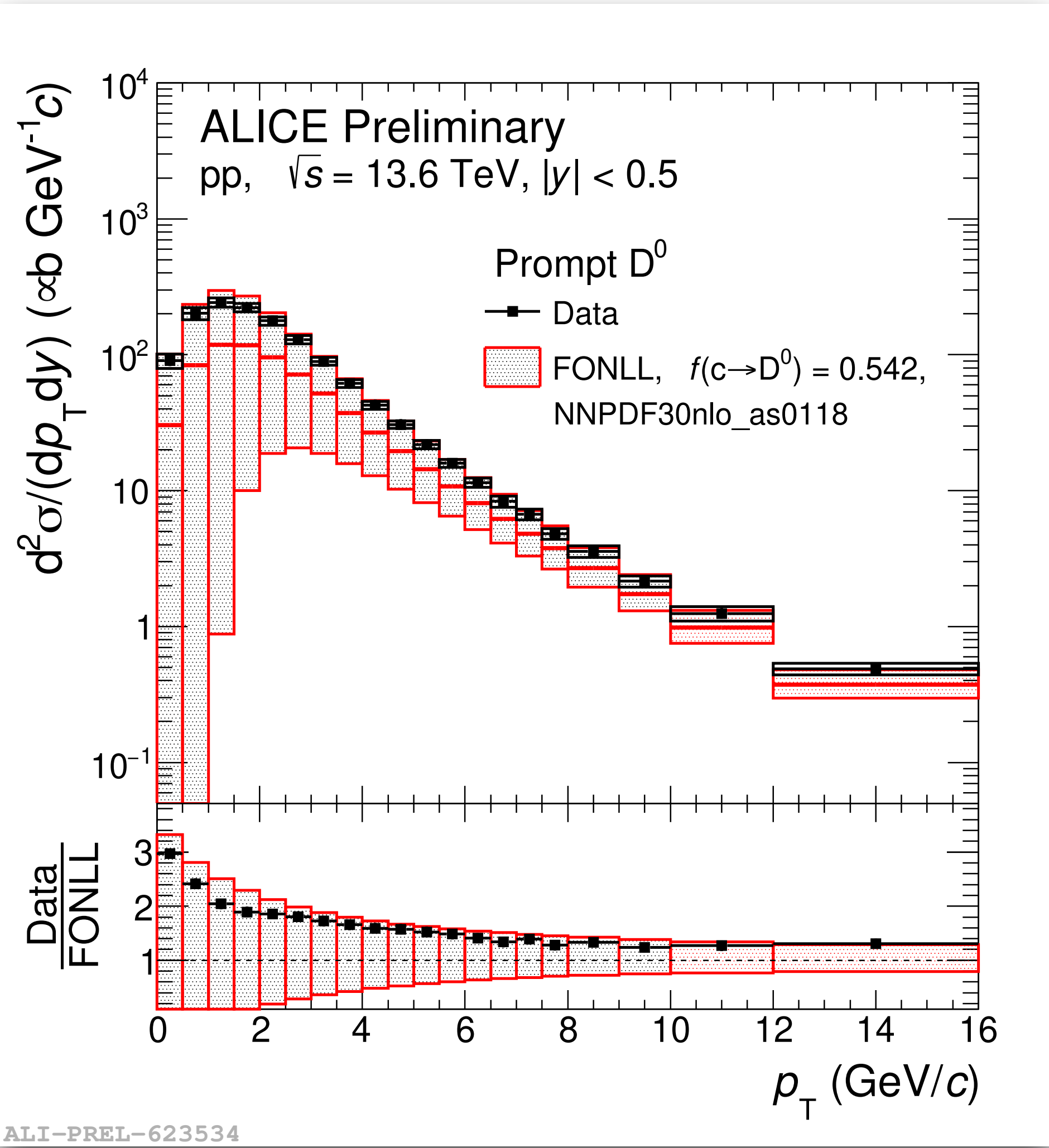

ALICE results can help constrain theoretical uncertainties in regions with large npQCD contributions

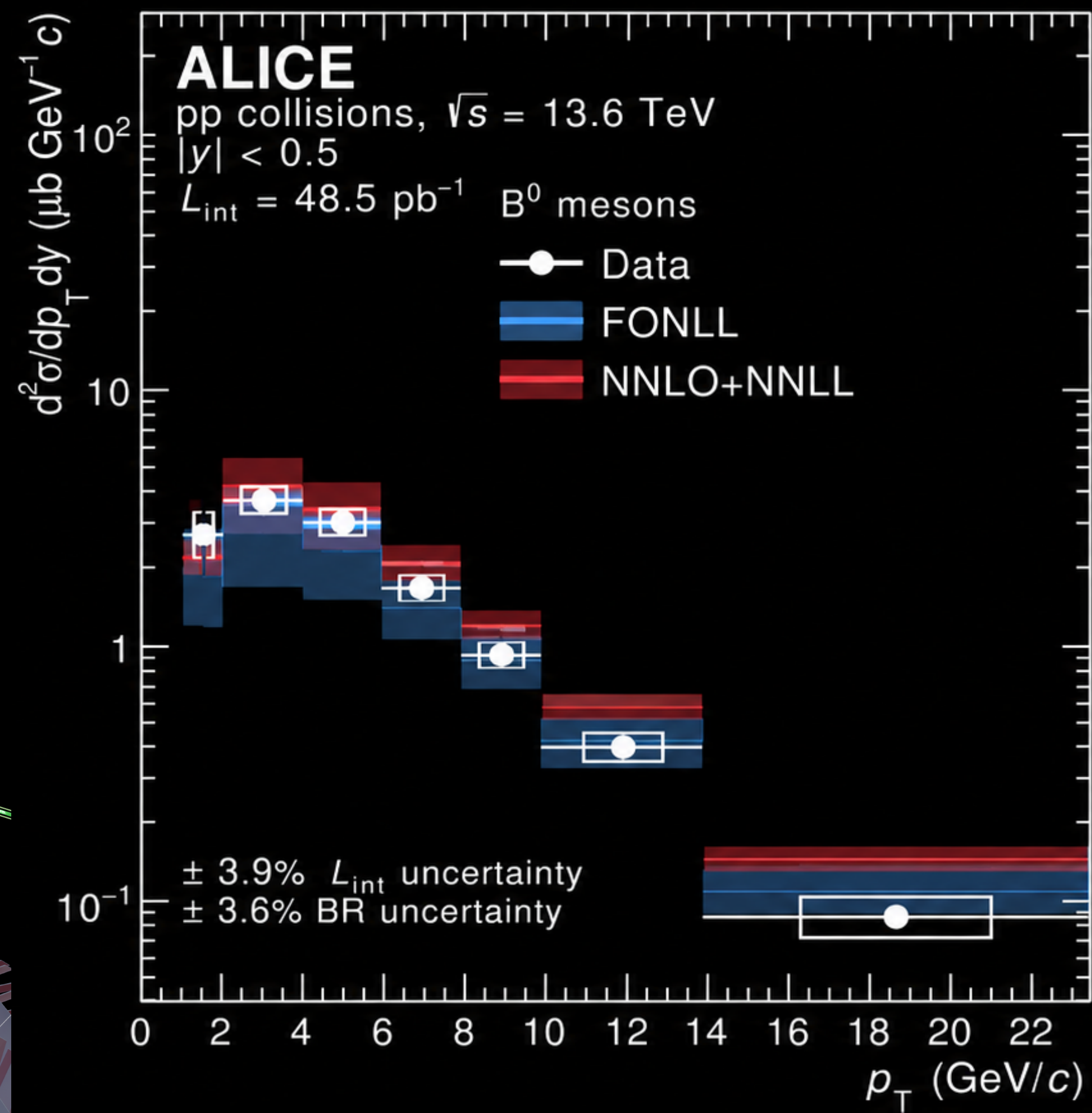
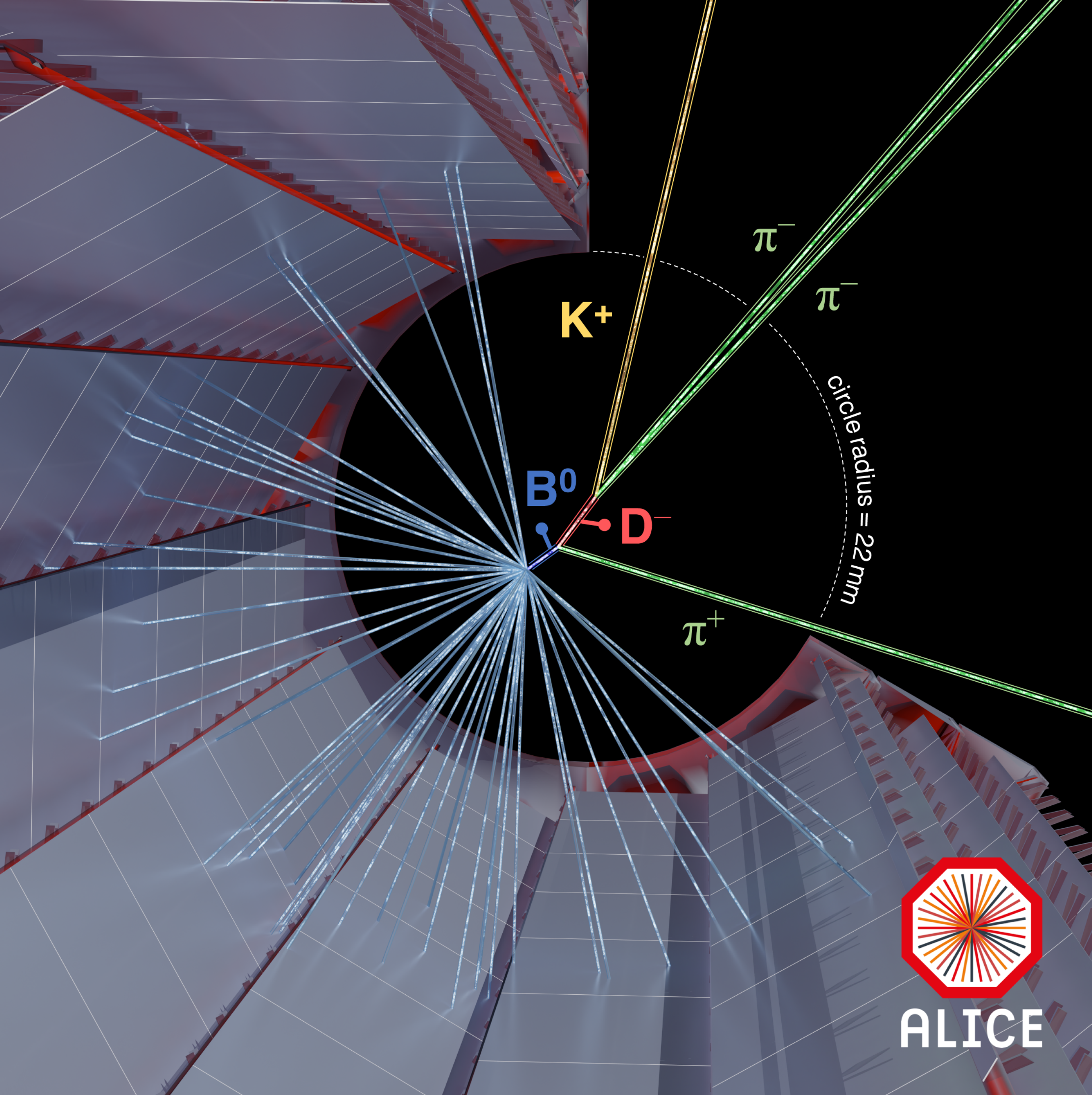

First LHC measurement of B⁰ production in a previously unexplored momentum range

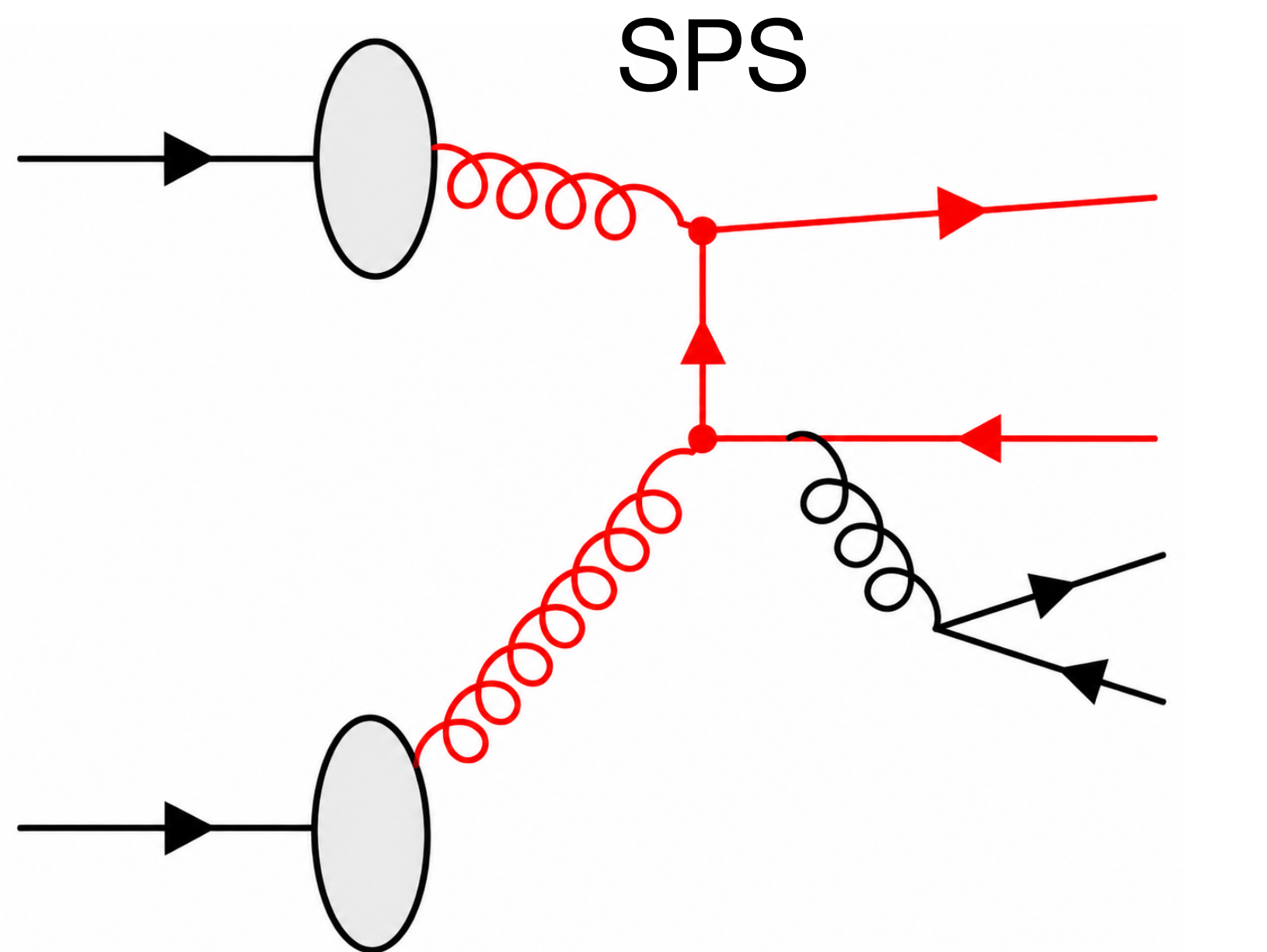
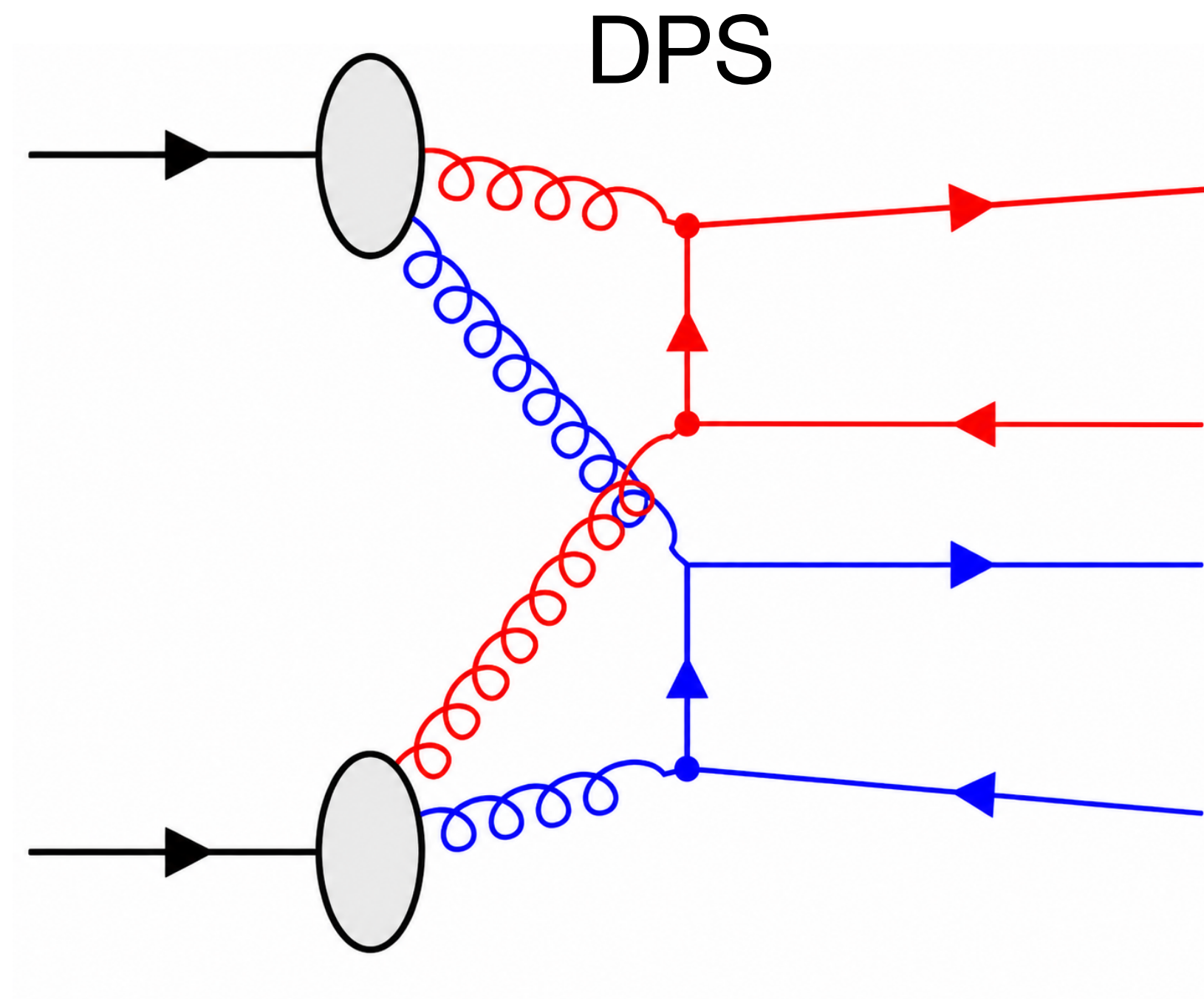

Prompt D^0 , $|y| < 0.6$
 $p_T > 0.5 \text{ GeV}/c$

Inclusive J/Ψ
 $2.5 < y < 4.0$, $p_T > 0$

D^0 - J/Ψ
 $1.9 < \Delta y < 4.6$

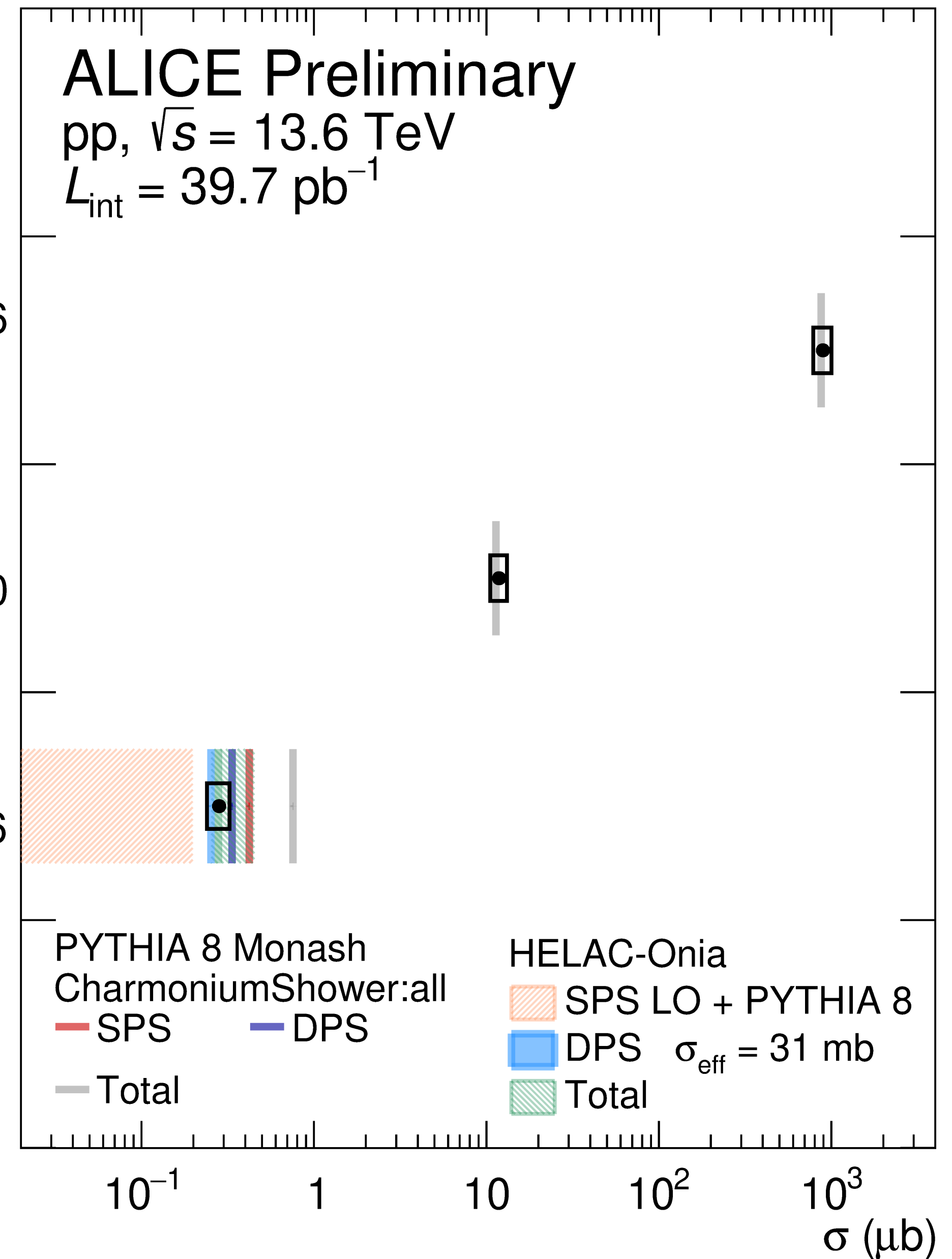

ALI-PREL-609949

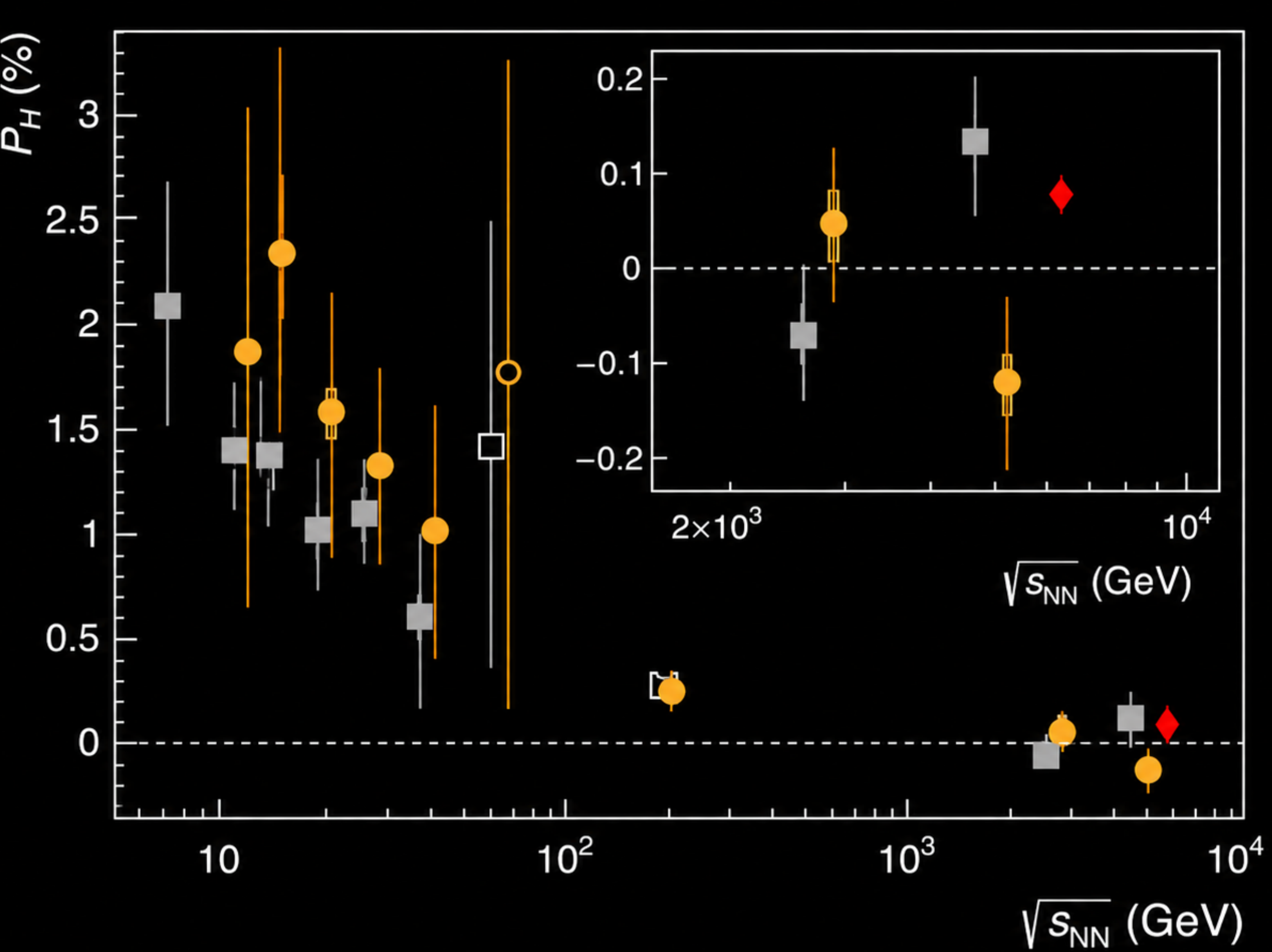

ALICE Preliminary
 ◆ $(\Lambda + \bar{\Lambda})/2$
 Pb–Pb 15–50%
 $0.5 < p_T < 5$ GeV/c
 $|y| < 0.5$
 ALICE PRC 101, 044611 (2020)
 ▲ Λ ● $\bar{\Lambda}$
 Pb–Pb 15–50%
 $0.5 < p_T < 5$ GeV/c
 $|y| < 0.5$
 STAR Nature 548, 62-65 (2017)
 ▲ Λ ● $\bar{\Lambda}$
 □ Λ ○ $\bar{\Lambda}$
 Au–Au 20–50%
 $0.5 < p_T < 6$ GeV/c
 $|\eta| < 0.8$

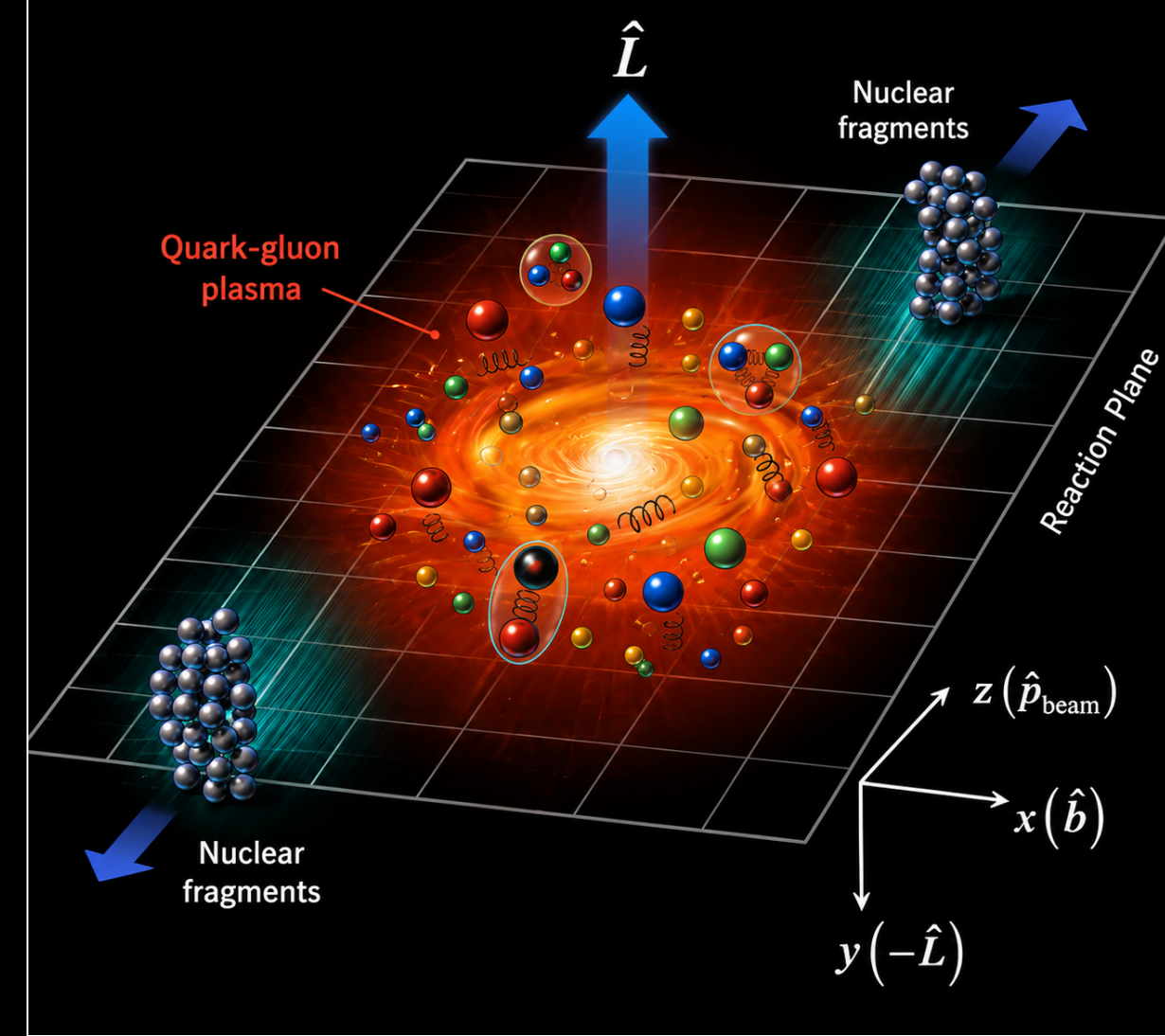

Perspective

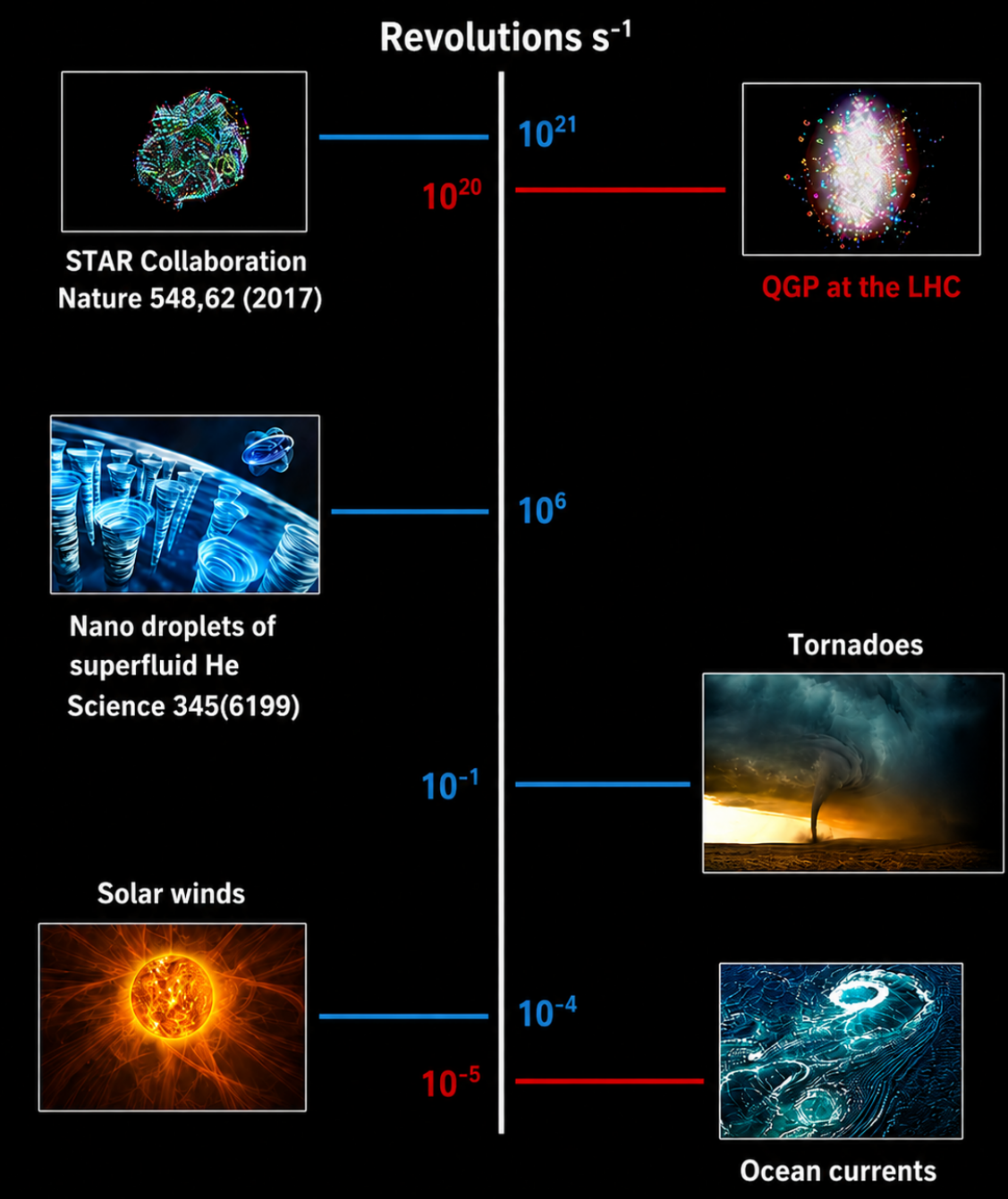

Large L deposited in the collisions causes the QGP to rotate
 Global vorticity of the medium results in a polarisation of the Λ hyperon spin

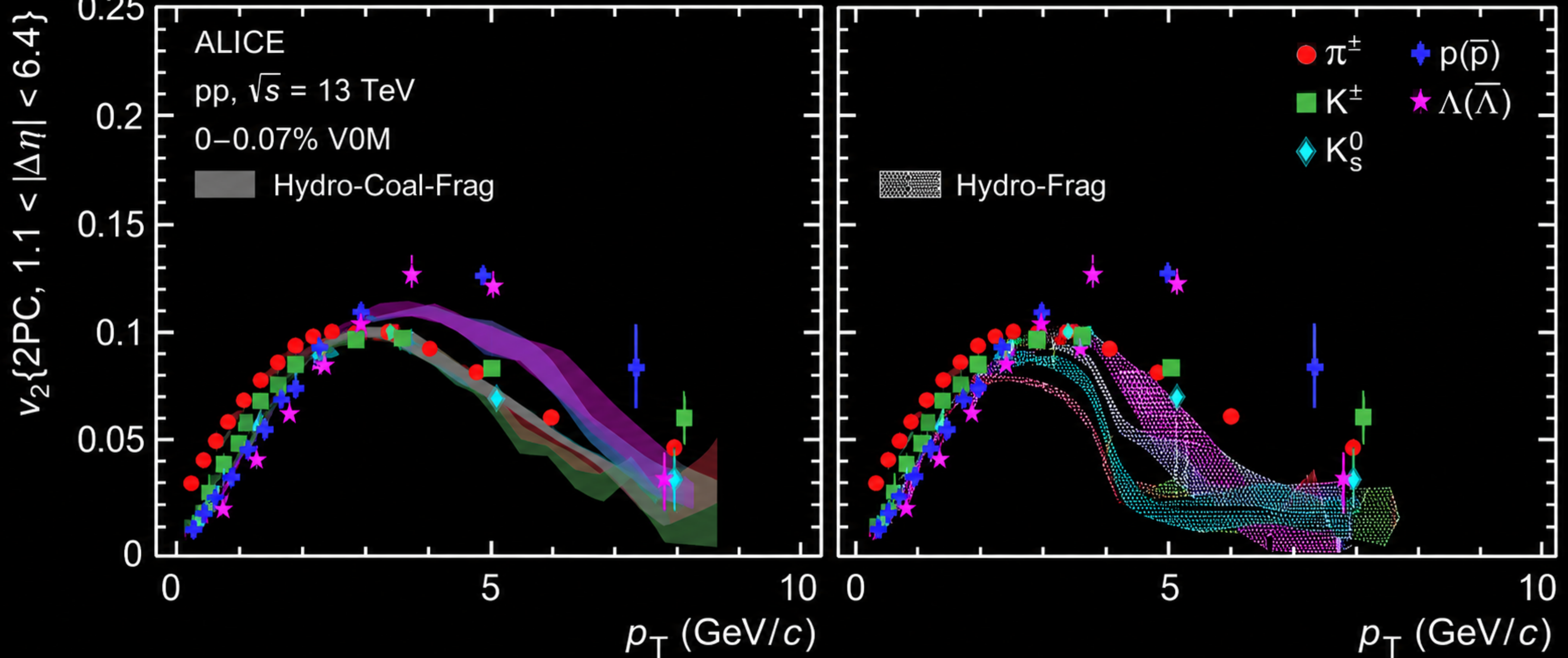

nature communications

Explore content ▾ About the journal ▾ Publish with us ▾

nature > nature communications > articles > article

Article | [Open access](#) | Published: 20 March 2026

Observation of partonic flow in proton–proton and proton–nucleus collisions

The ALICE Collaboration

Nature Communications 17, Article number: 2585 (2026) | [Cite this article](#)

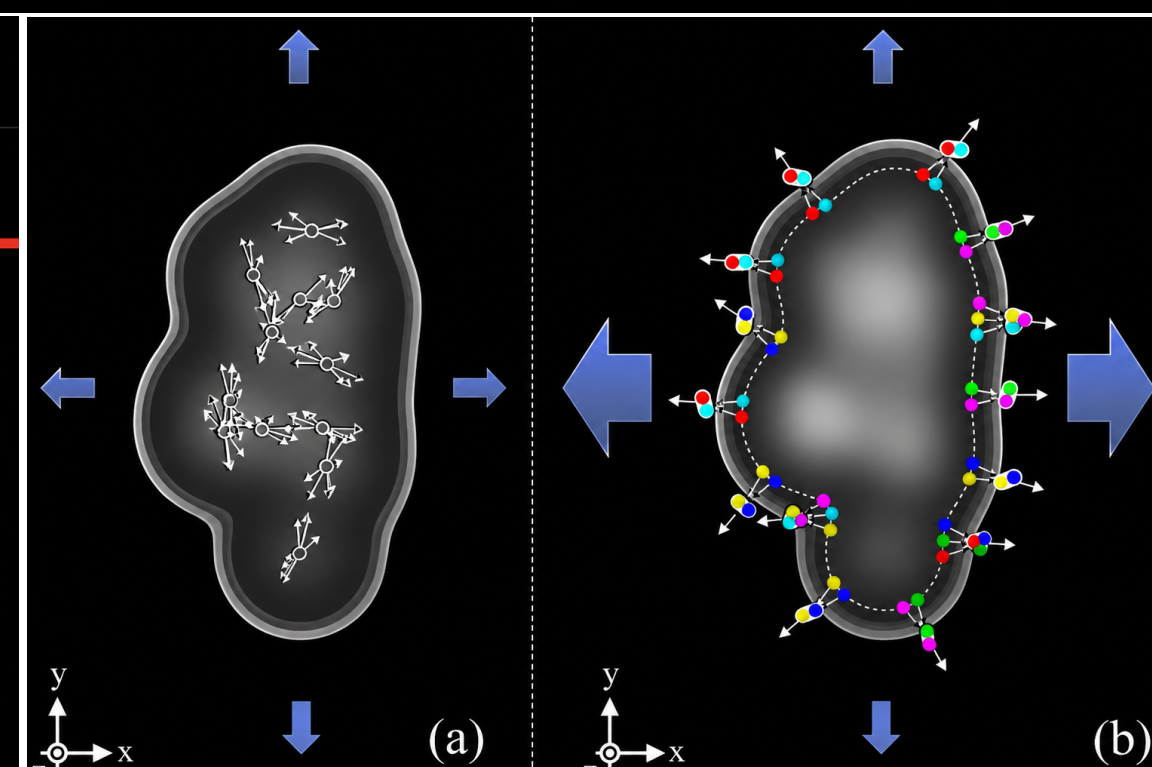

More than 10 years of evidence for QGP-like phenomena in small systems: collectivity in high-multiplicity pp and p–A collisions and apparent strangeness enhancement, but still no indication of jet quenching

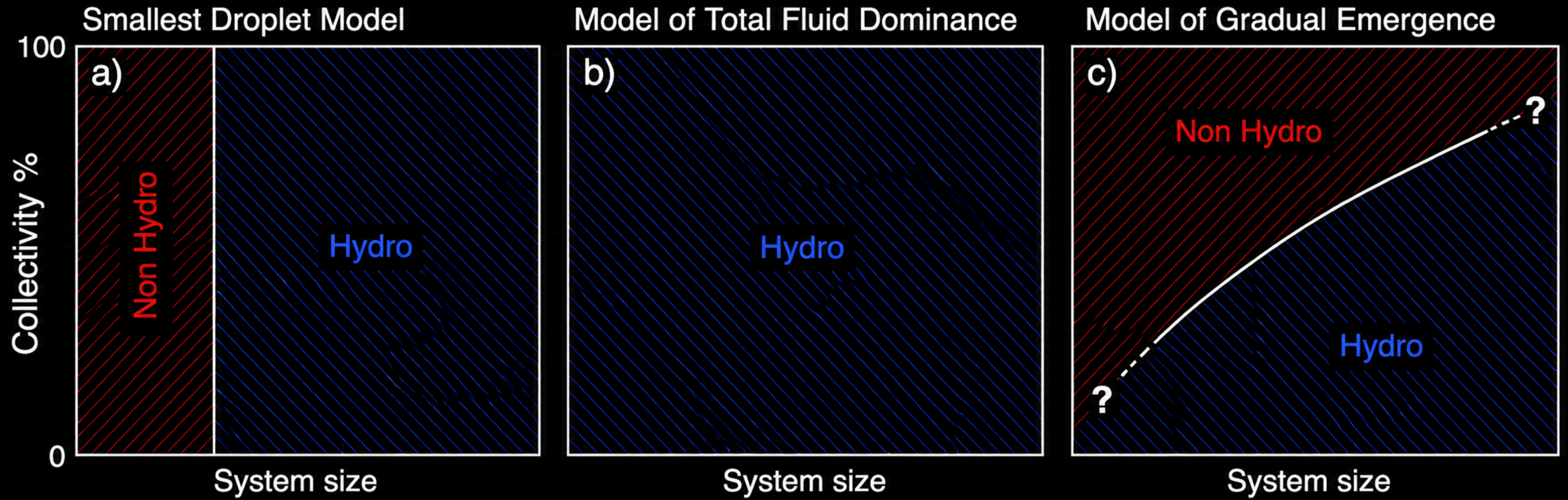

J.F. Grosse-Oetringhaus, U.A. Wiedemann, A Decade of Collectivity in Small Systems, CERN-TH-2024-110

Flow in ultra small systems?

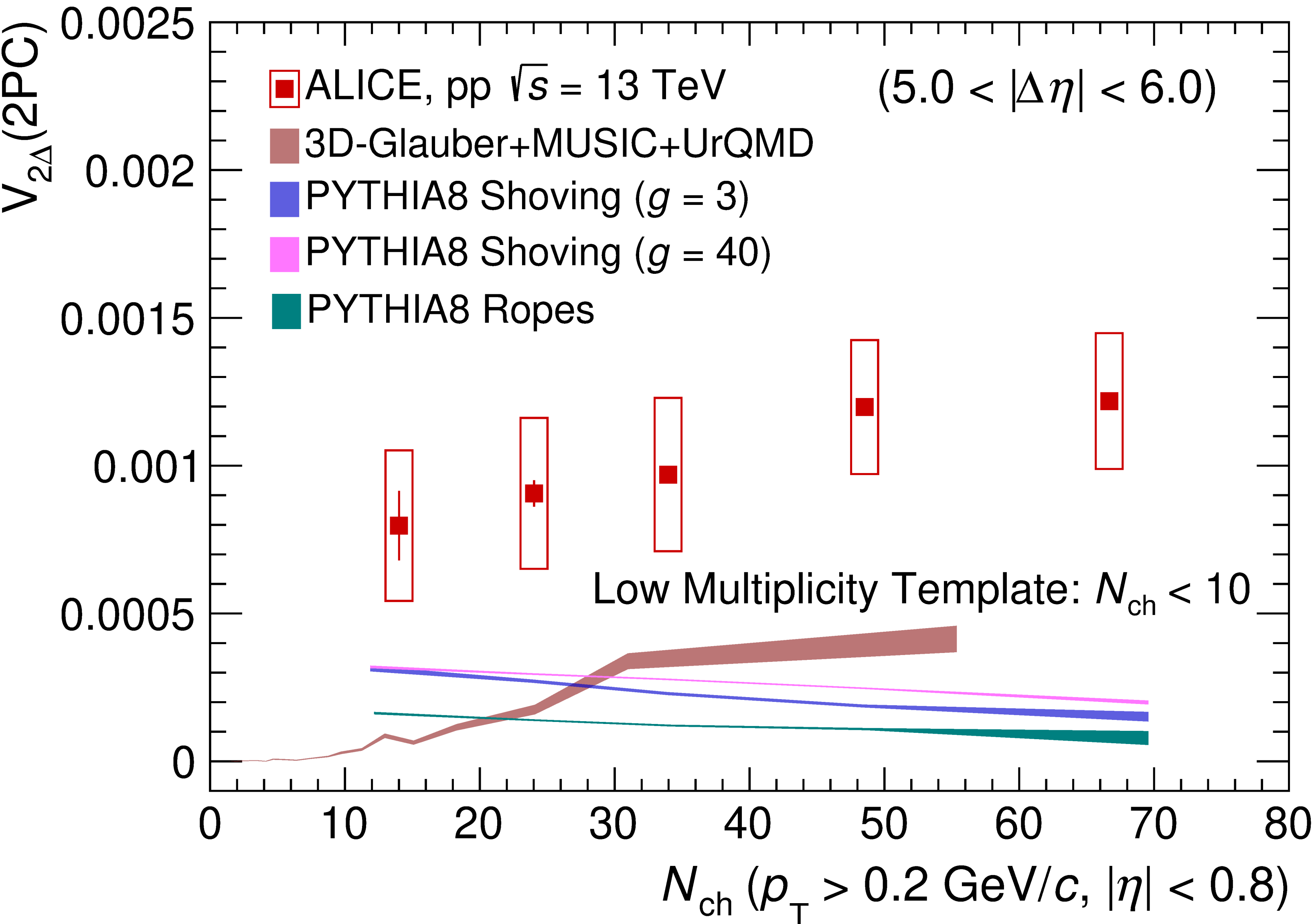

ALICE, arXiv:2504.02359

$$Y(\Delta\phi) = FY^{LM}(\Delta\phi) + G \left[1 + \sum_{n=2}^3 2V_{n\Delta} \cos(n\Delta\phi) \right]$$

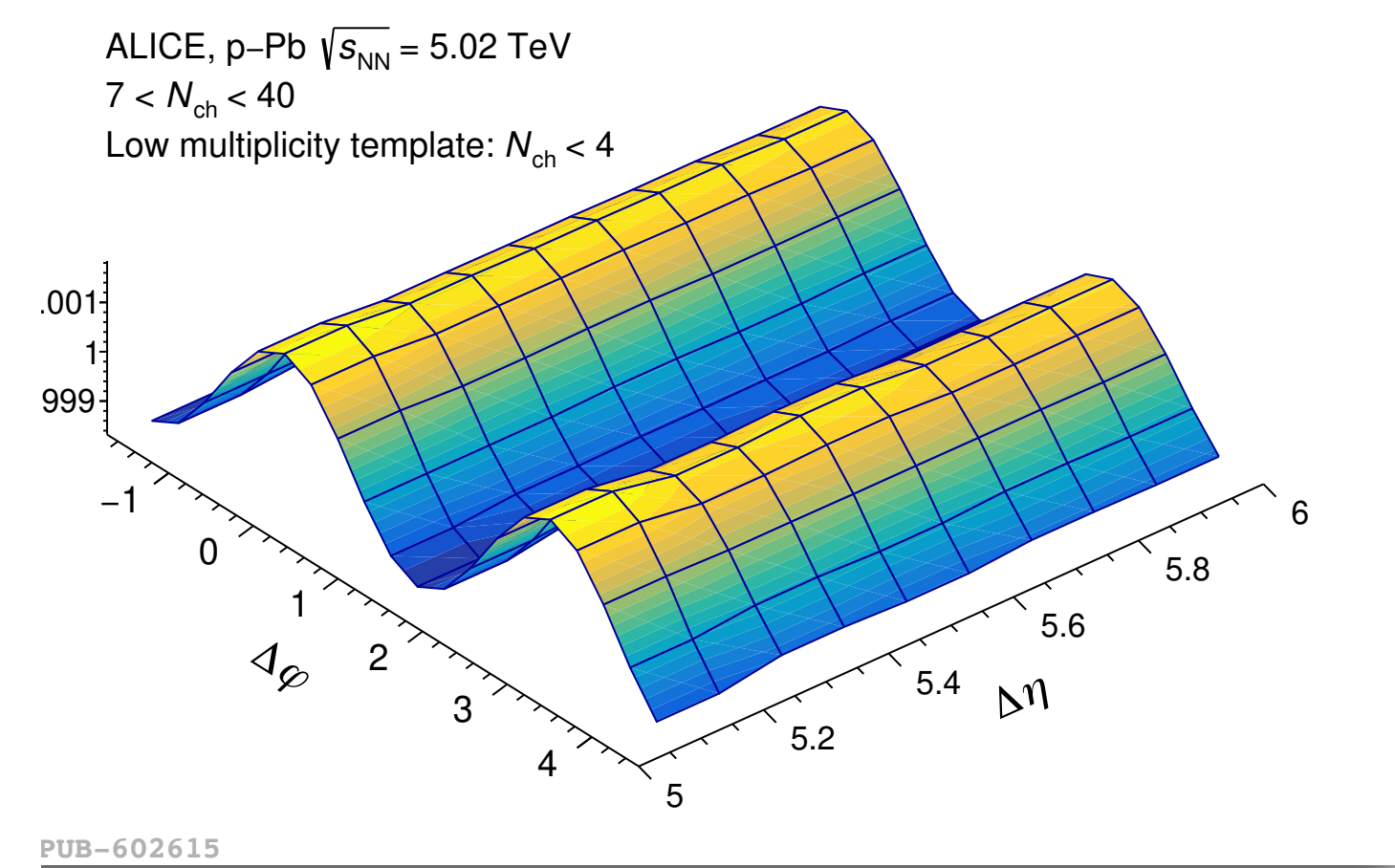

Origin of non-zero v_2 in ultra small systems:

Dushmanta Sahu [17/06 12:05 'Sala B' Session]

Charged pion, kaon and (anti)proton p_T spectra in pp collisions at $\sqrt{s} = 13.6$ TeV

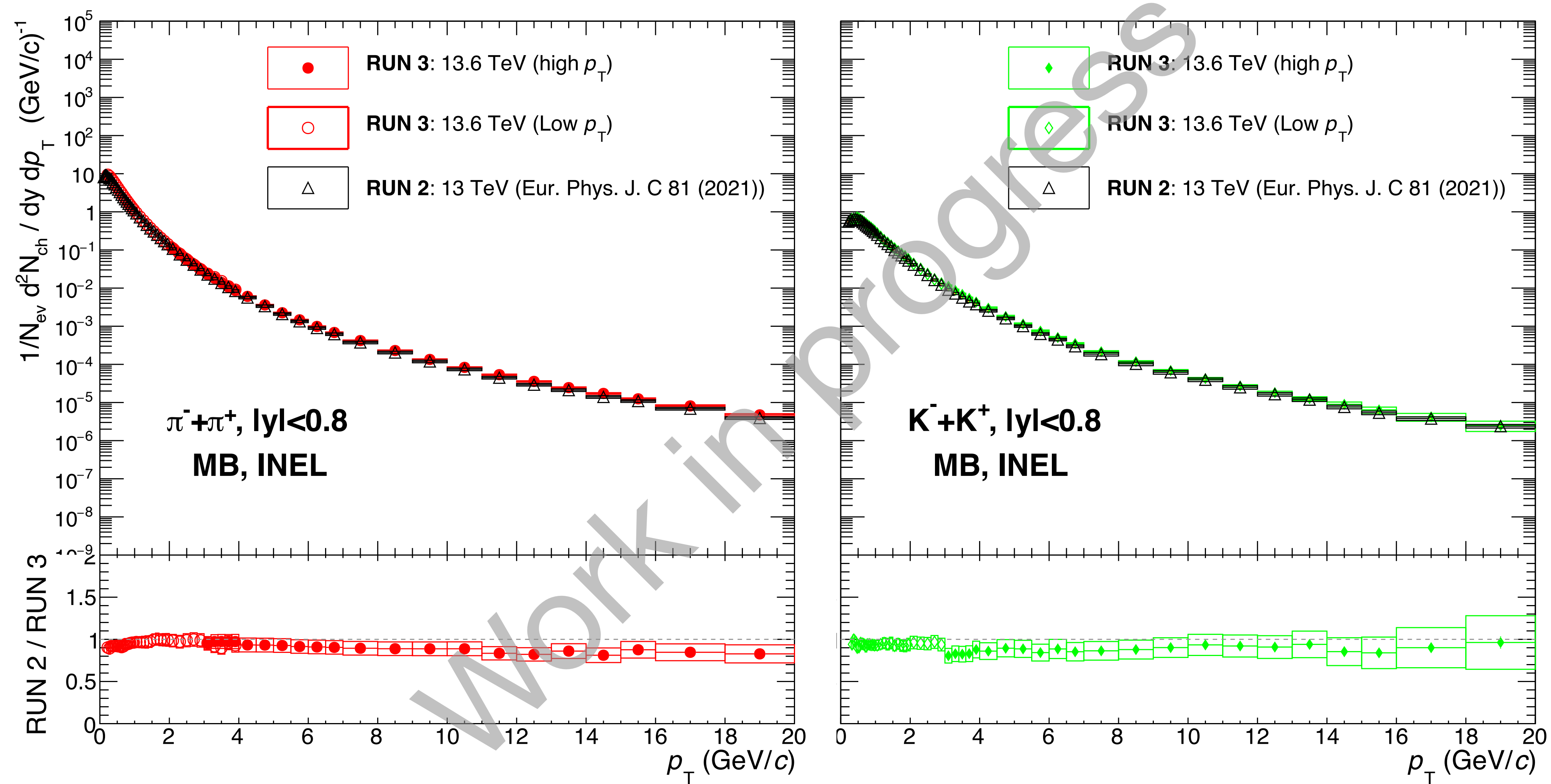

Paper proposal: July 1st, 2026. Identified hadron production as a function of FT0 multiplicity in pp

Paola Vargas [Poster Session]

High- p_T leading charged particle

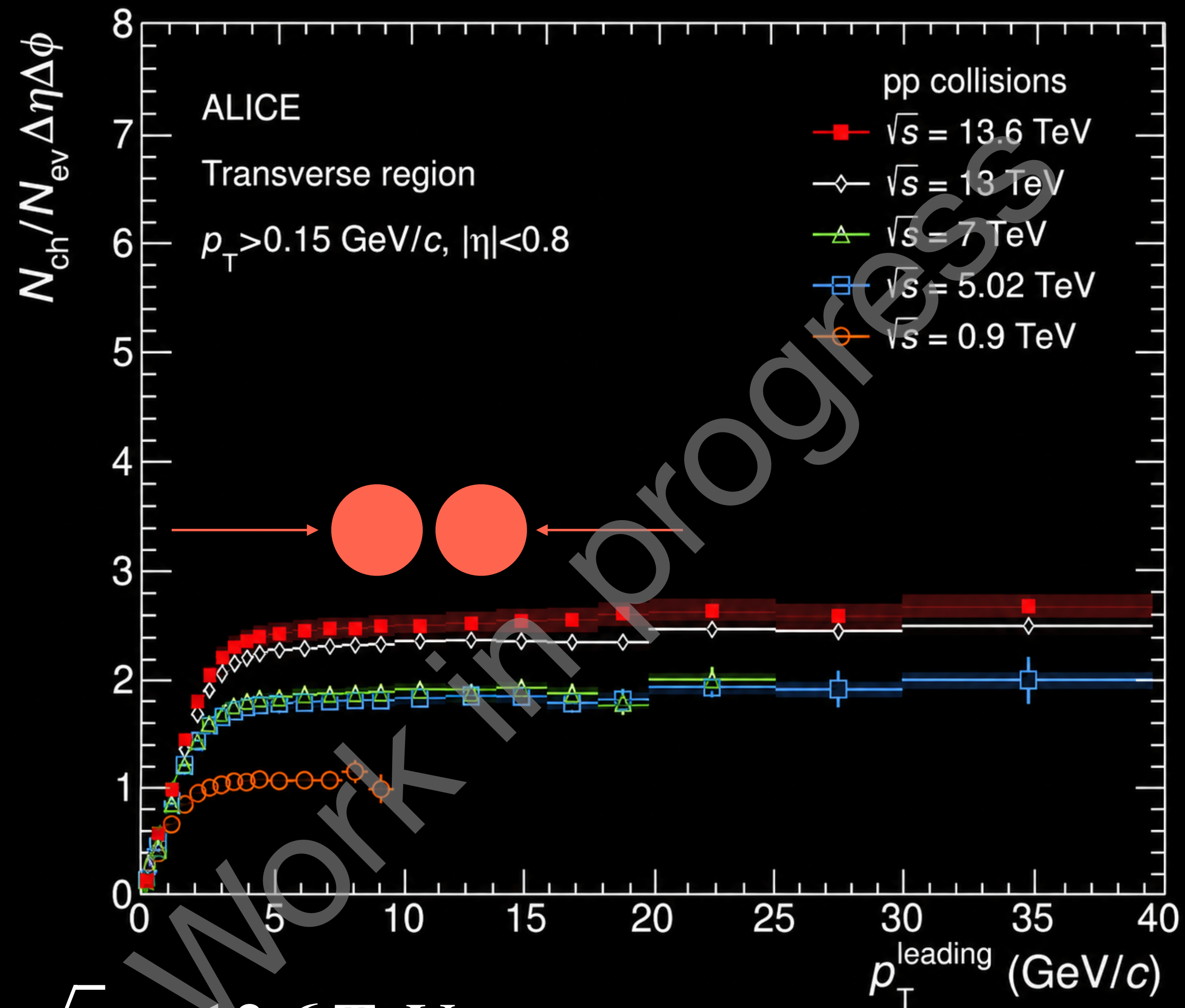
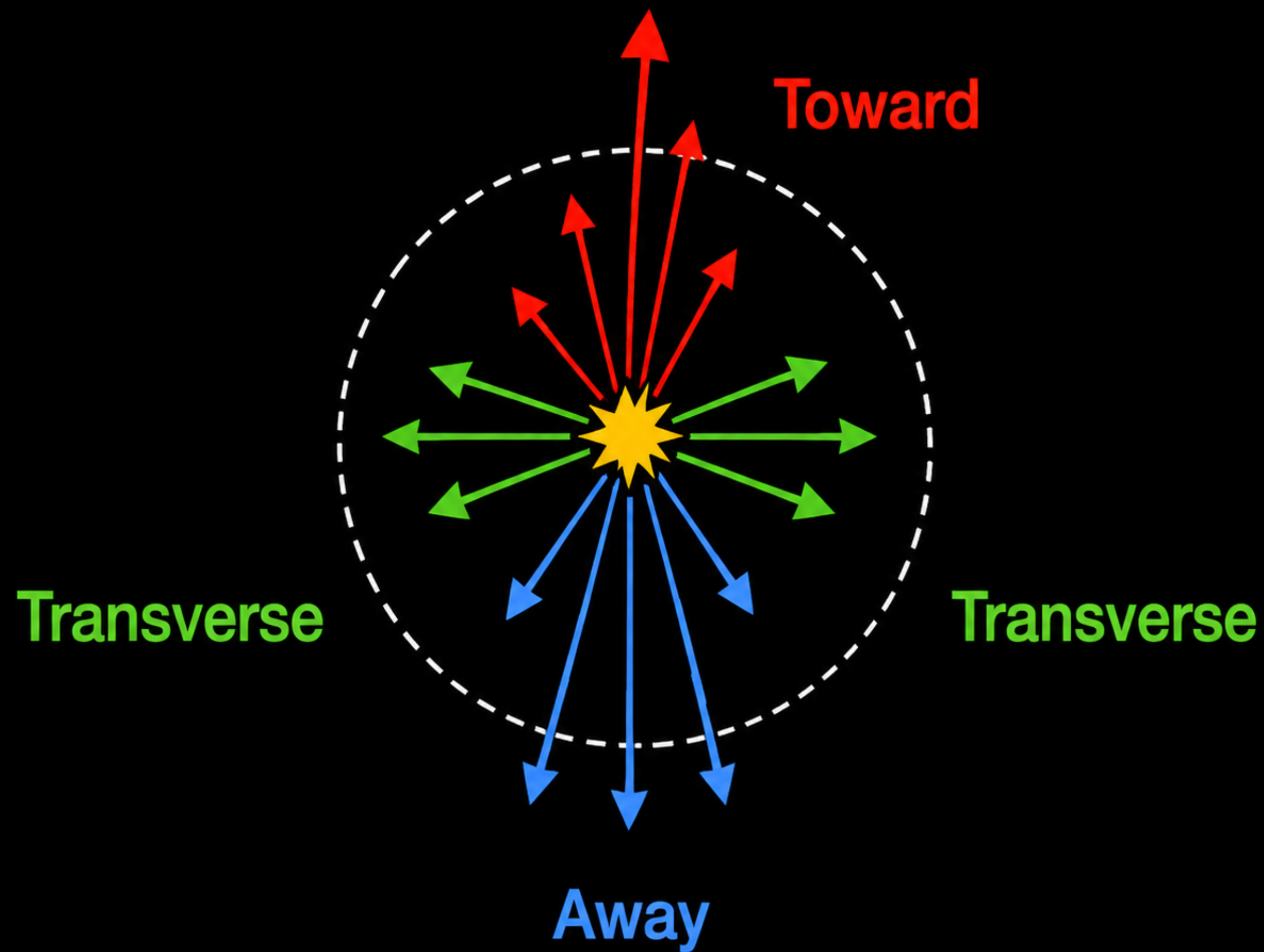

Underlying event activity in pp collisions at $\sqrt{s} = 13.6$ TeV
Energy dependence of UE activity in pp collisions, approval: July 1st, 2026

Jesús Eduardo Muñoz

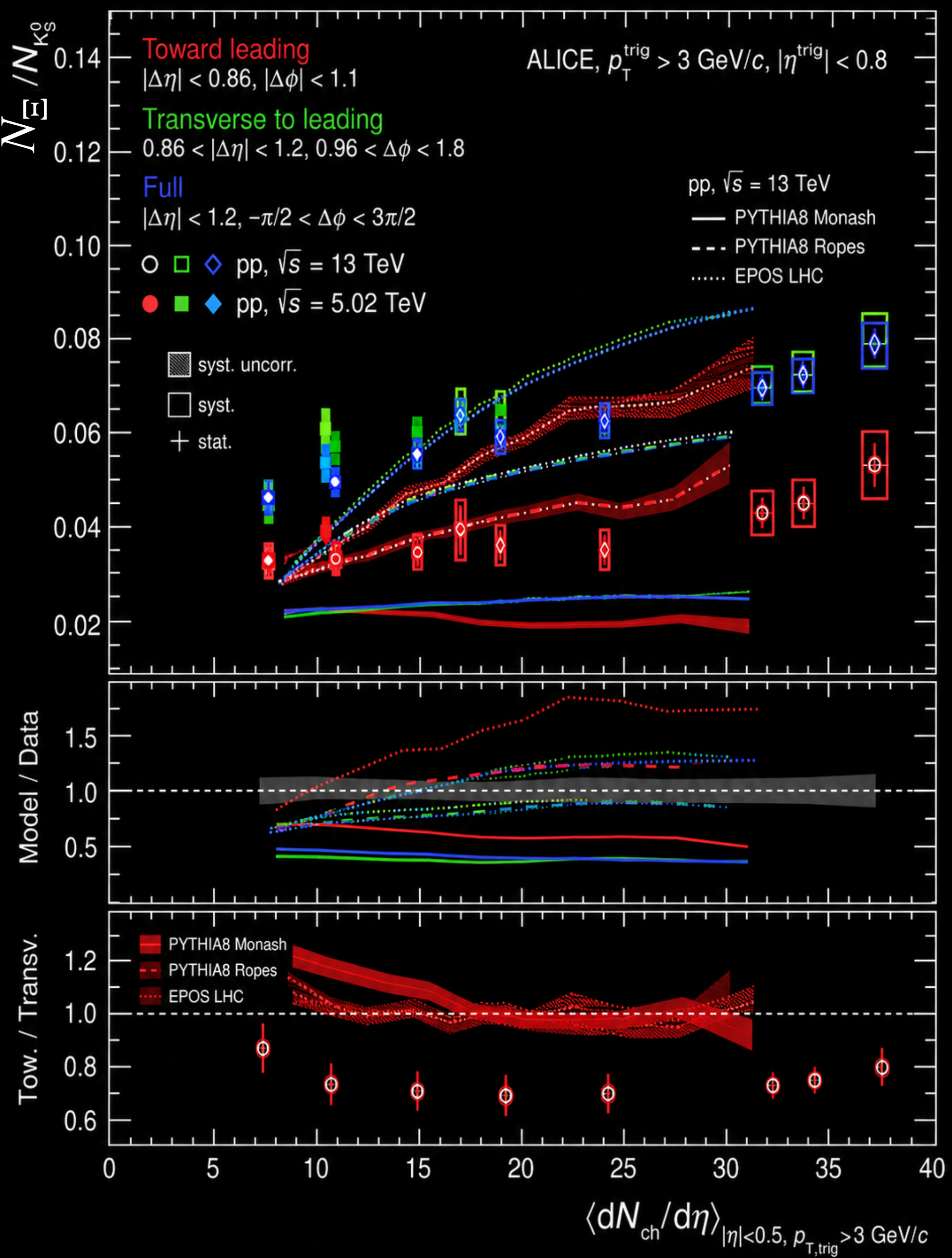

ALICE pp, $\sqrt{s} = 13 \text{ TeV}$
 V0M Multiplicity Percentile 0–100 %
 h- K_S^0 correlations

$3 < p_T^{\text{trigg}} < 15 \text{ GeV}/c$
 $1.6 < p_T^{\text{assoc}} < 2.0 \text{ GeV}/c$

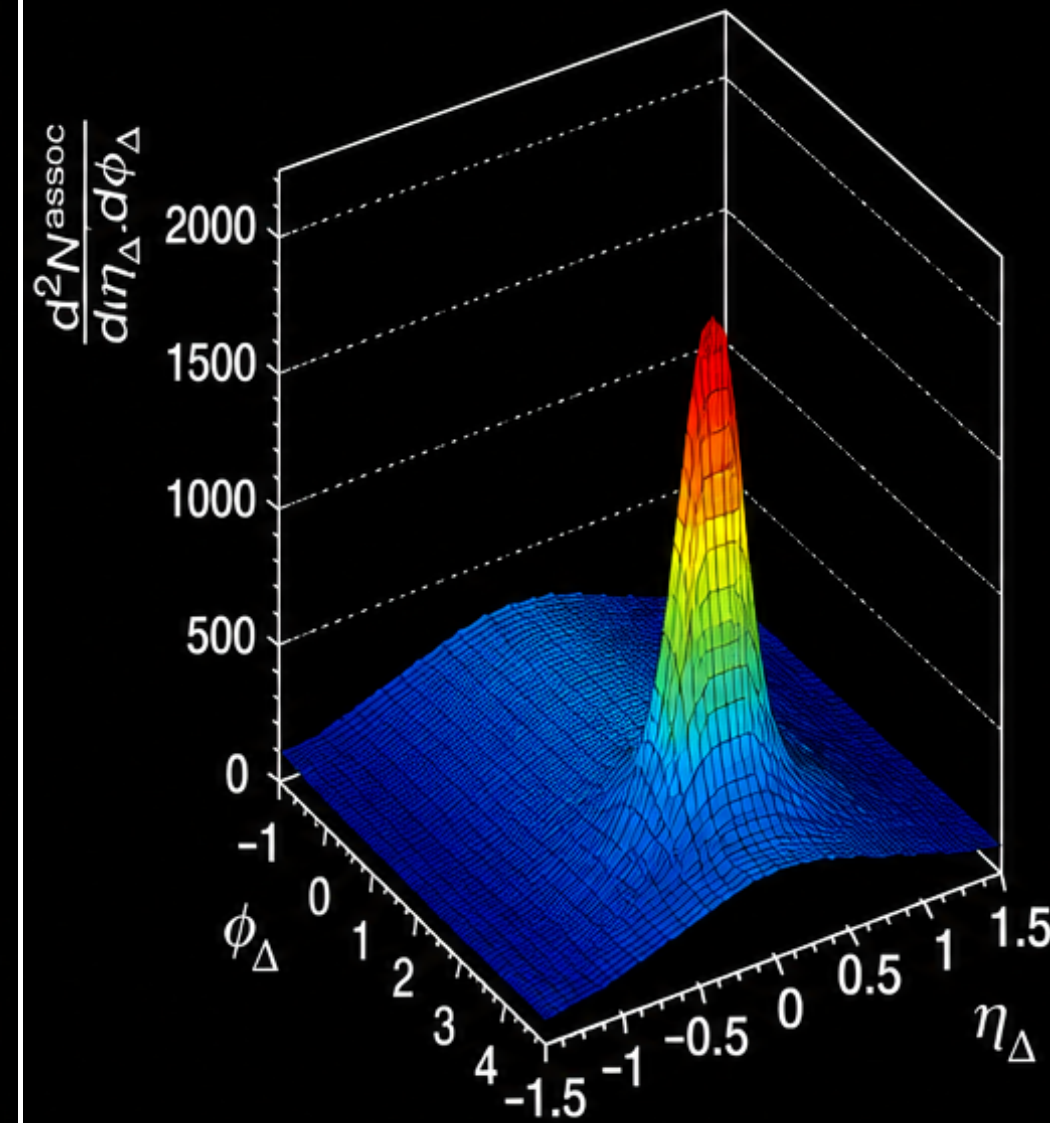

(a) Raw correlation
 $d^2 N^{\text{assoc}} / d\eta_\Delta d\phi_\Delta$

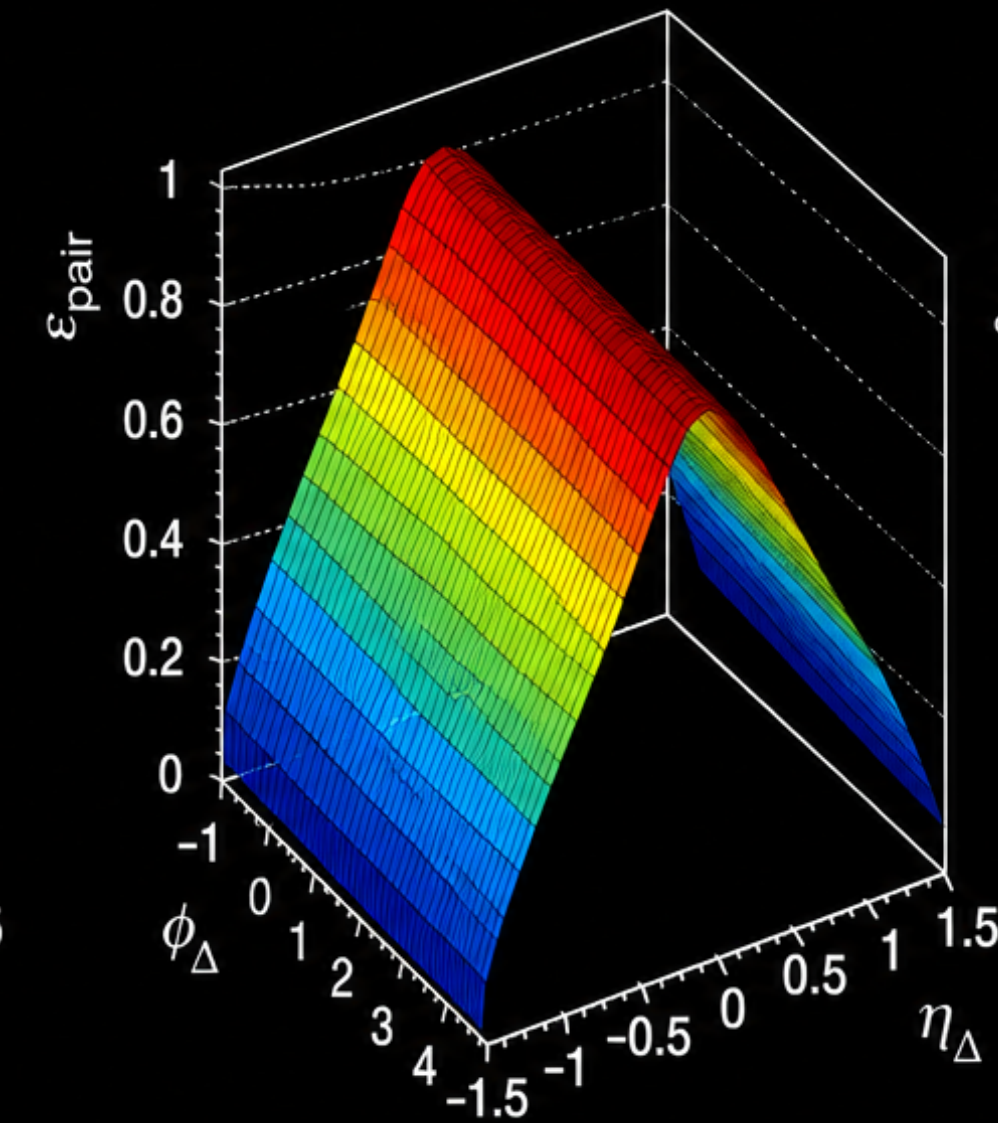

(b) Pair efficiency
 ϵ_{pair}

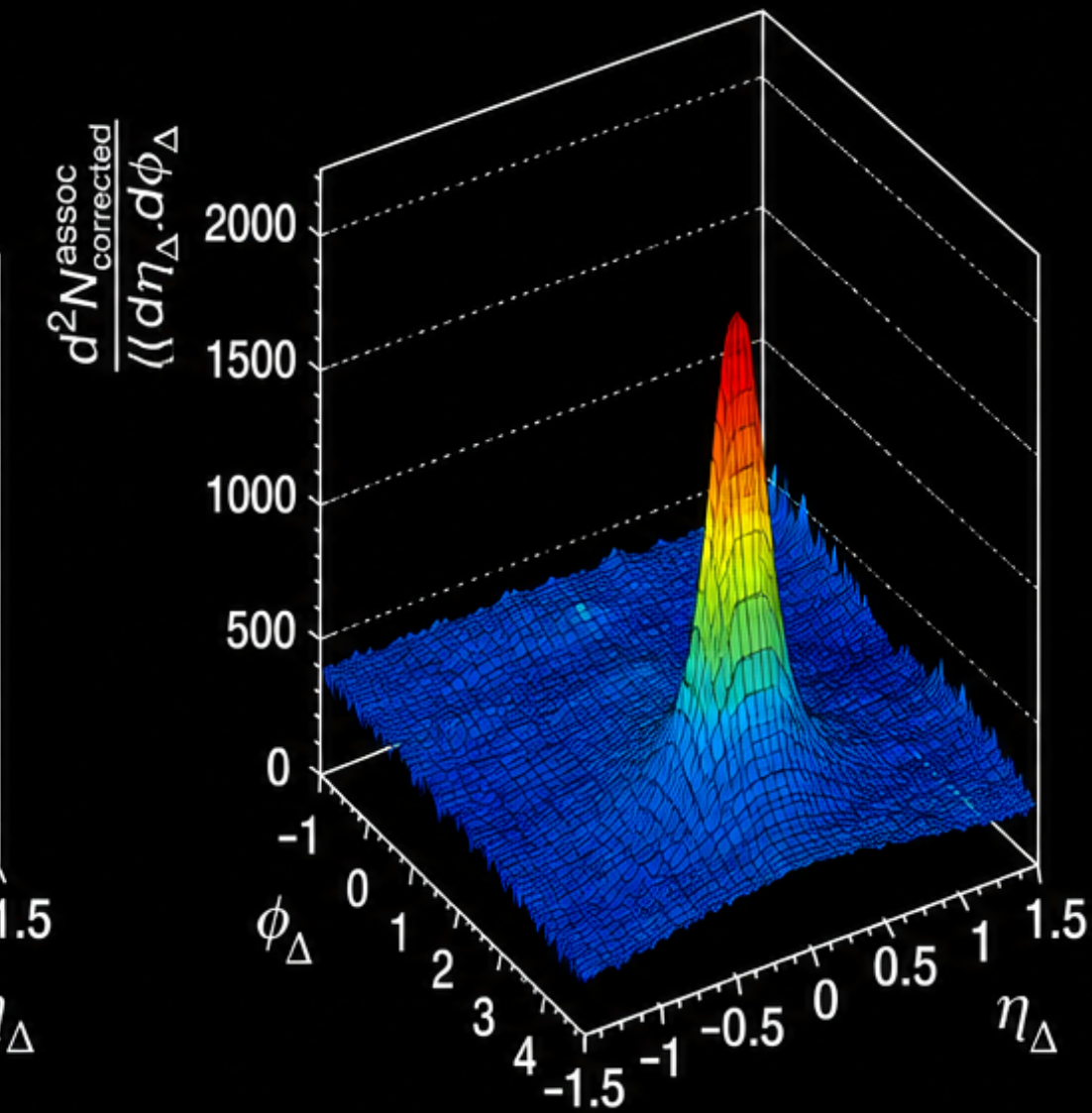

(c) Efficiency-corrected correlation
 $d^2 N^{\text{assoc}}_{\text{corrected}} / d\eta_\Delta d\phi_\Delta$

ALI-PUB-584358

ALICE, JHEP 09 (2024) 204

Strangeness enhancement in jets?

Origin of the apparent enhancement in the jet-like region:

Victor Vázquez [Poster Session]

Jet quenching in small systems?

Selection bias produces the broadening in high multiplicity pp collisions

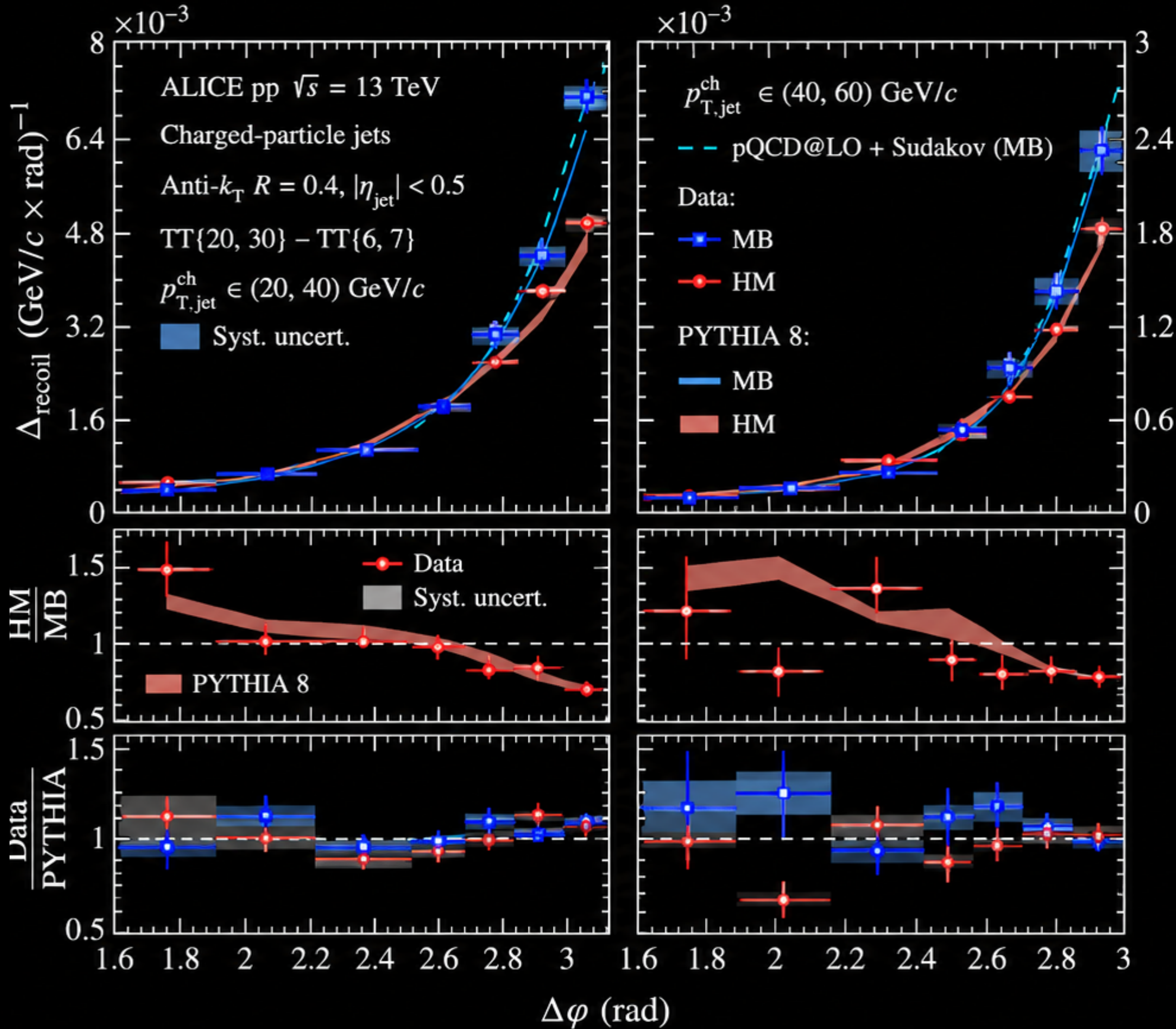
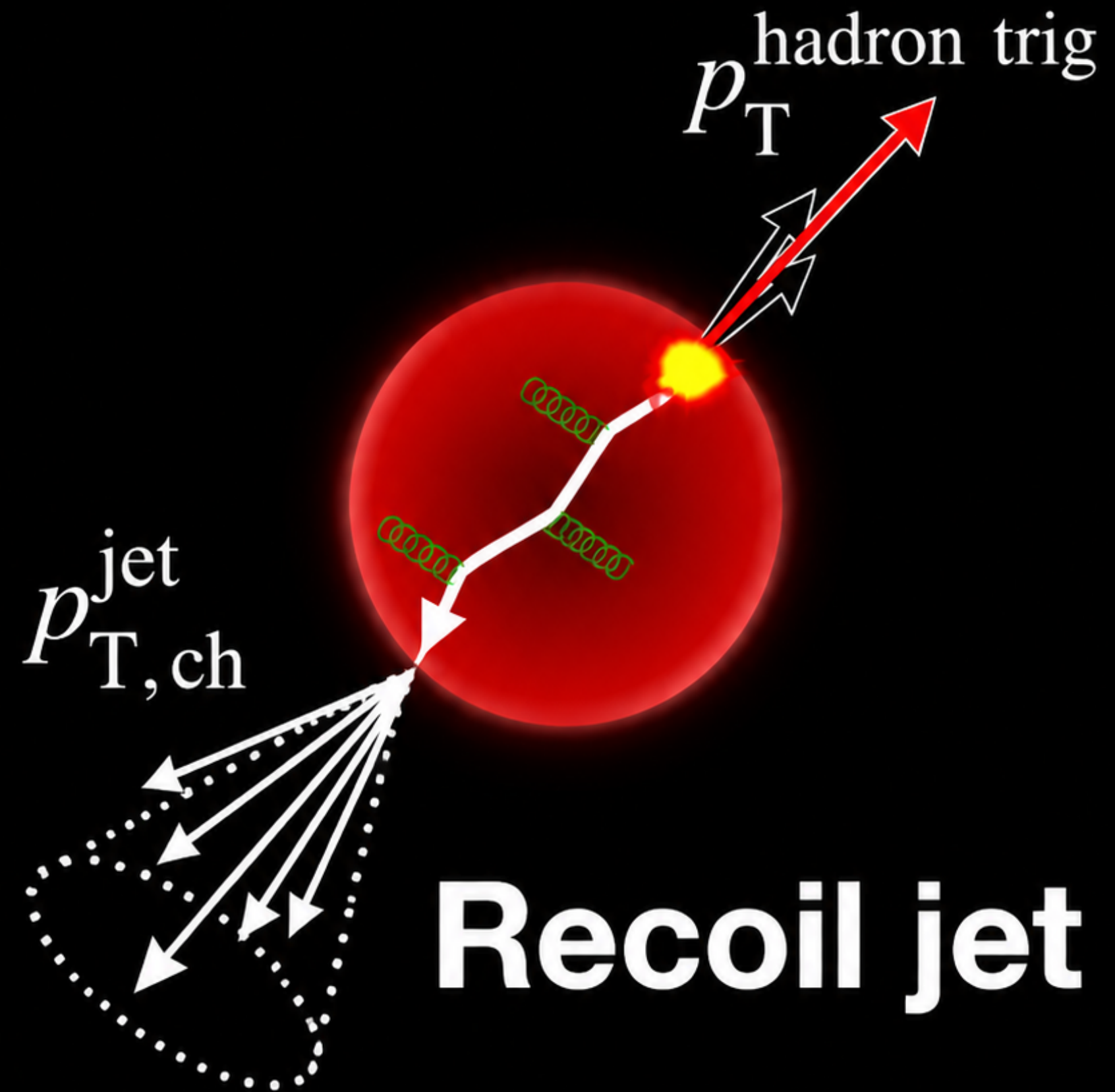

Flattenicity (A. Ortiz et al., PRD107 (2023) 7 076012; JPG51 (2024) 12 125003; JPG52 (2025) 9, 095001; ALICE, PRD111 (2025) 012010) has been implemented in the jet recoil study

Jesus Eduardo Muñoz [Poster Session]

Strong suggestion of QGP formation in OO collisions

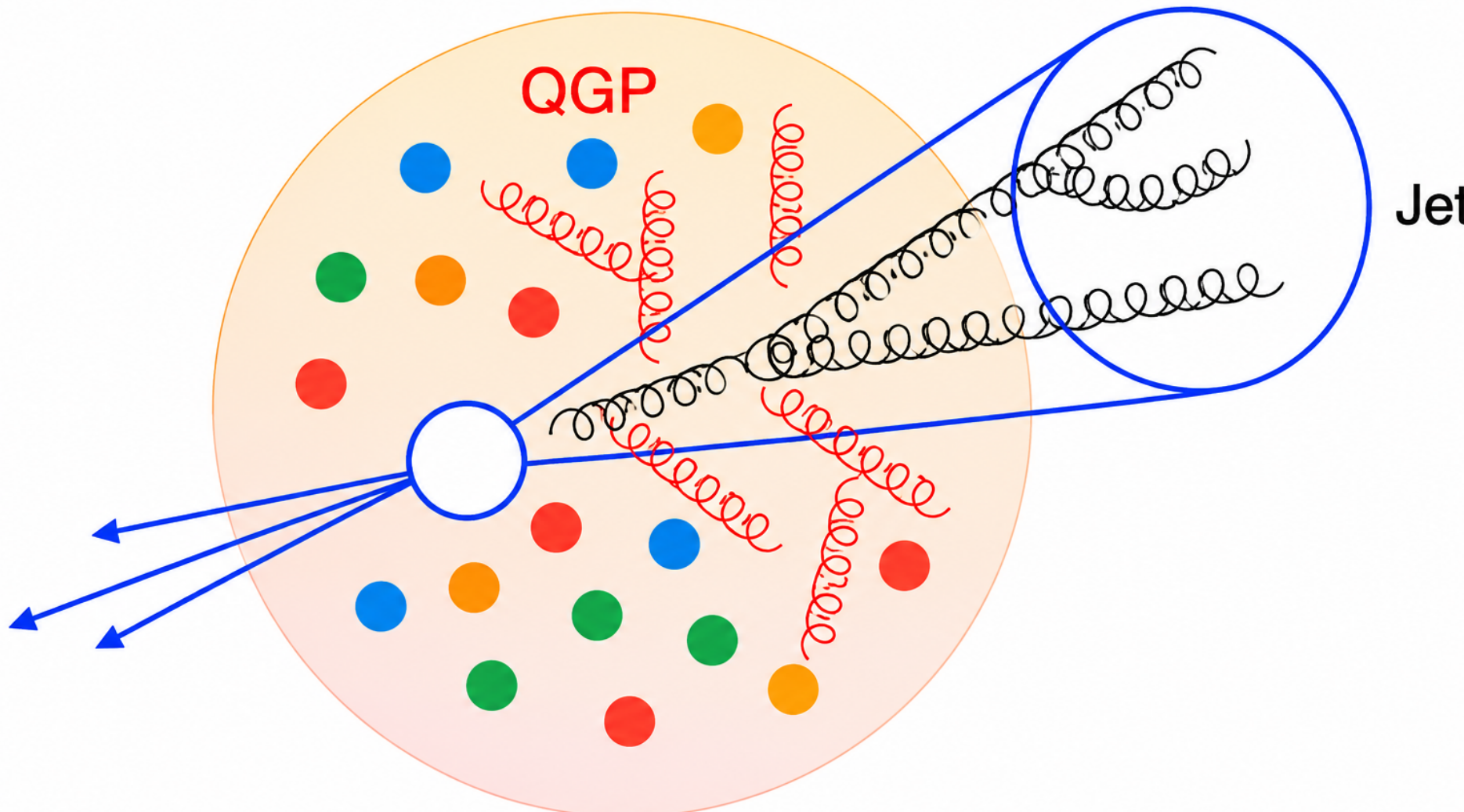

$$R_{OO} = \frac{1}{T_{AA}} \frac{d^2N/dydp_T}{d^2\sigma_{pp}/dydp_T}$$

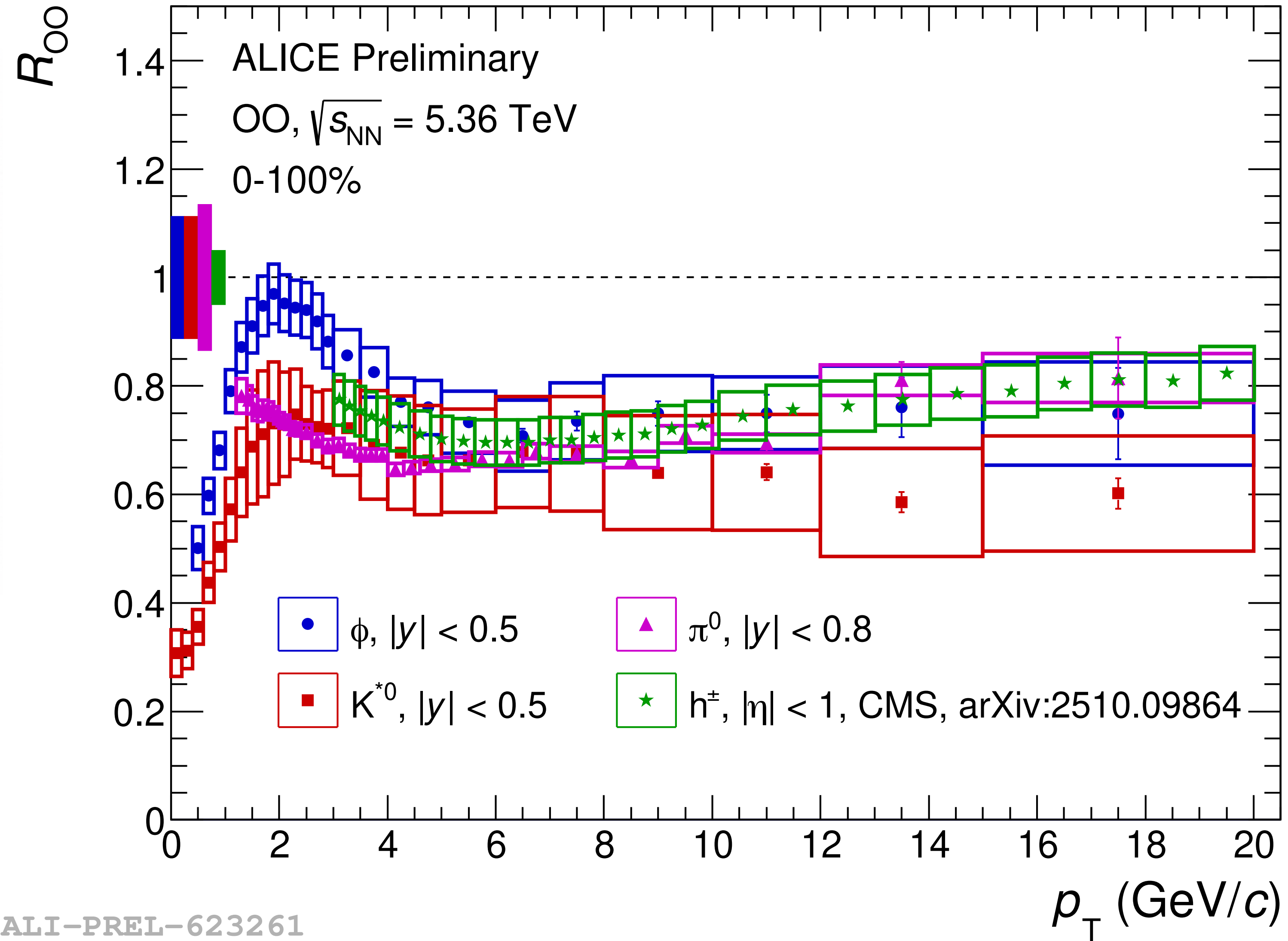

ALI-PREL-623261

OO collisions suppressed compared to pO
 baseline - indicates the presence of hot nuclear
 effects beyond nPDF effects

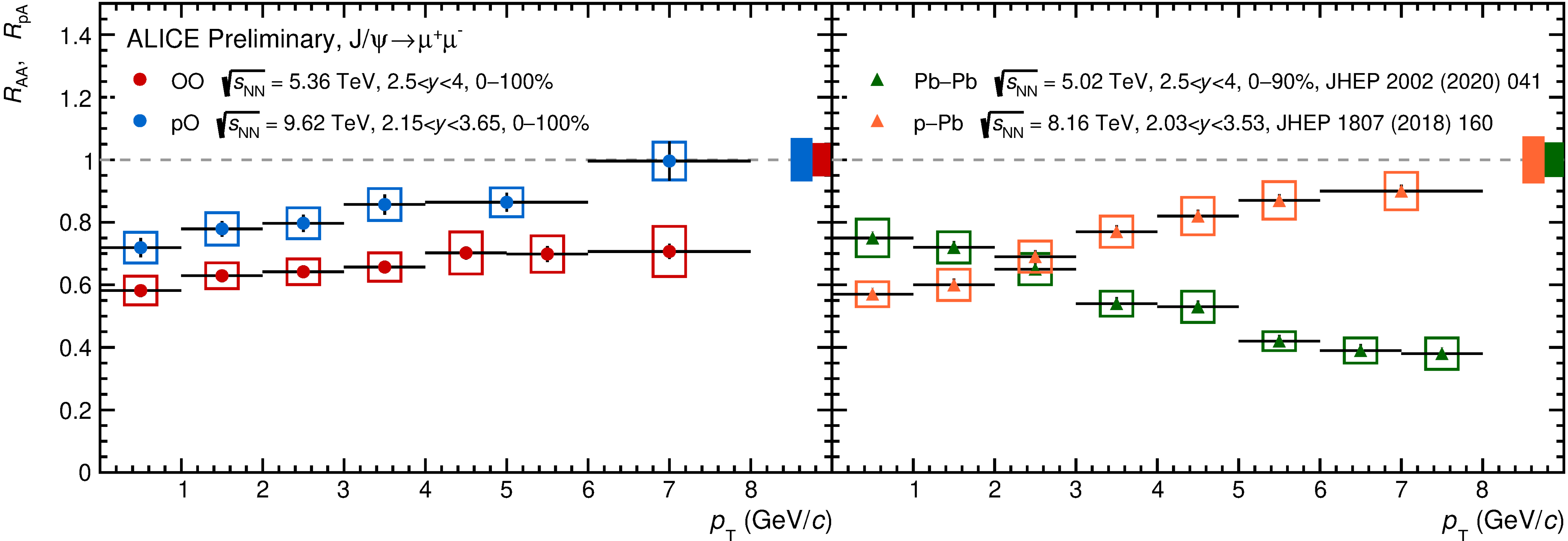
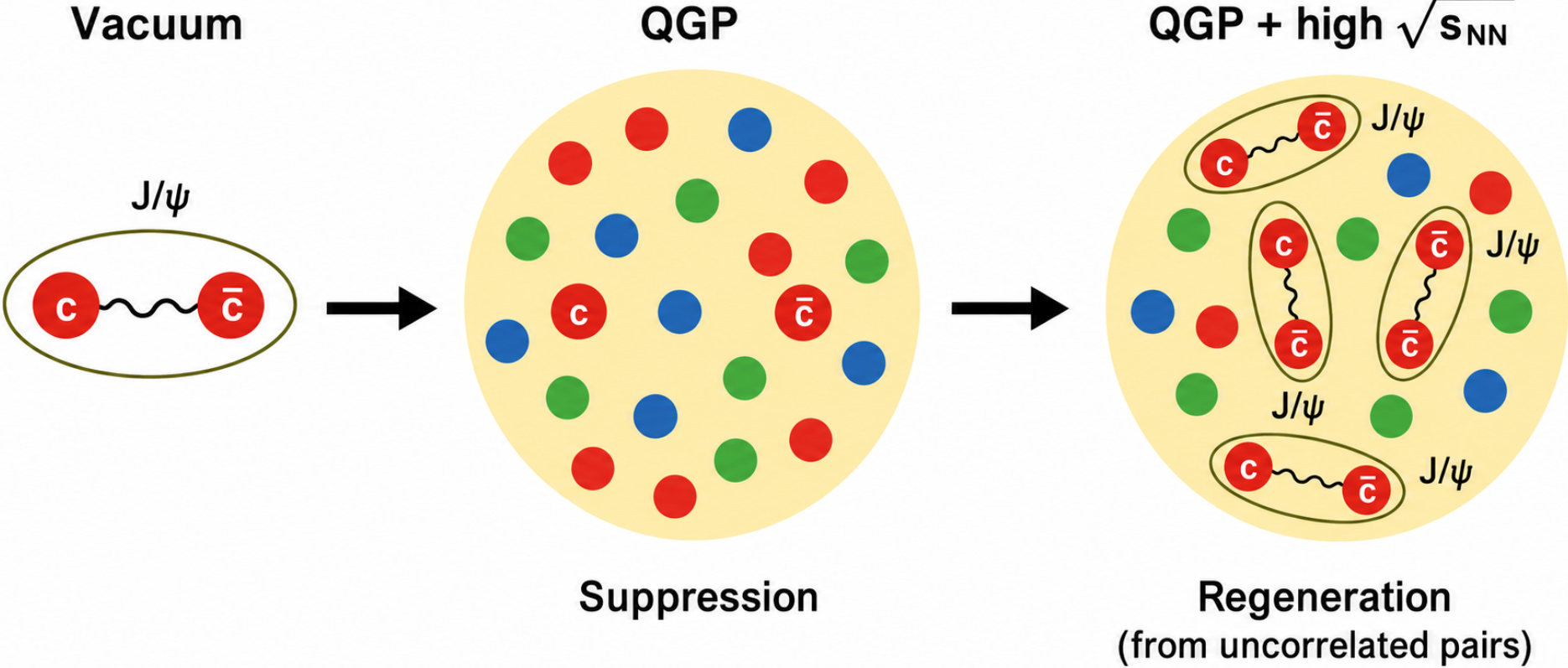

ALI-PREL-623785

Future plans

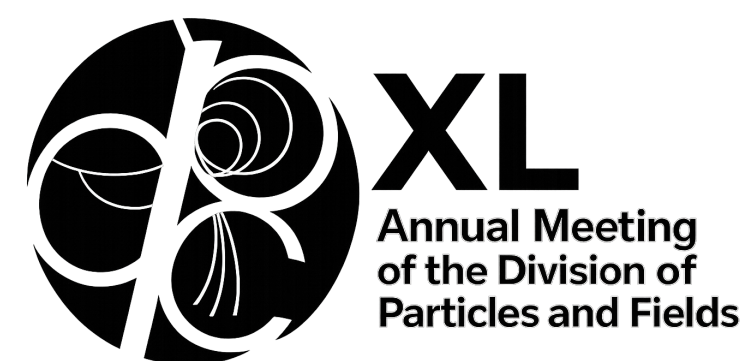

today

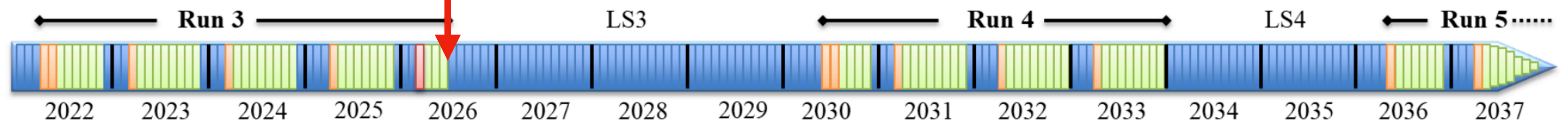

Commissioning
Physics run

Goal: determine small-x gluon density in the nucleus by measuring forward production of isolated direct photons, π^0 , jets

Final prototype of FoCal (tested at SPS)

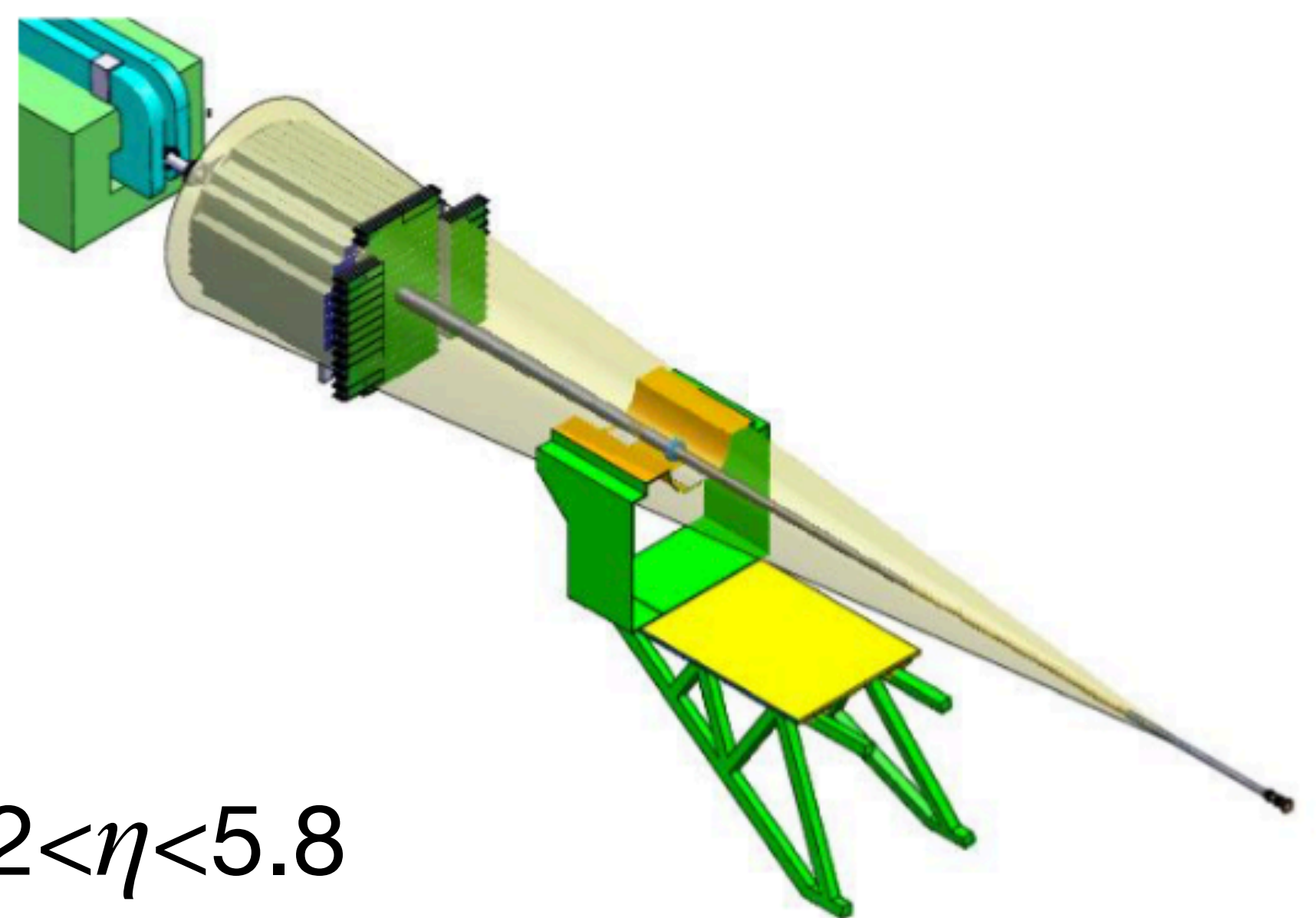

$$3.2 < \eta < 5.8$$

Highly granular Si+W electromagnetic calorimeter (FoCal-E)

Cu+scintillating-fiber hadronic calorimeter (FoCal-H)

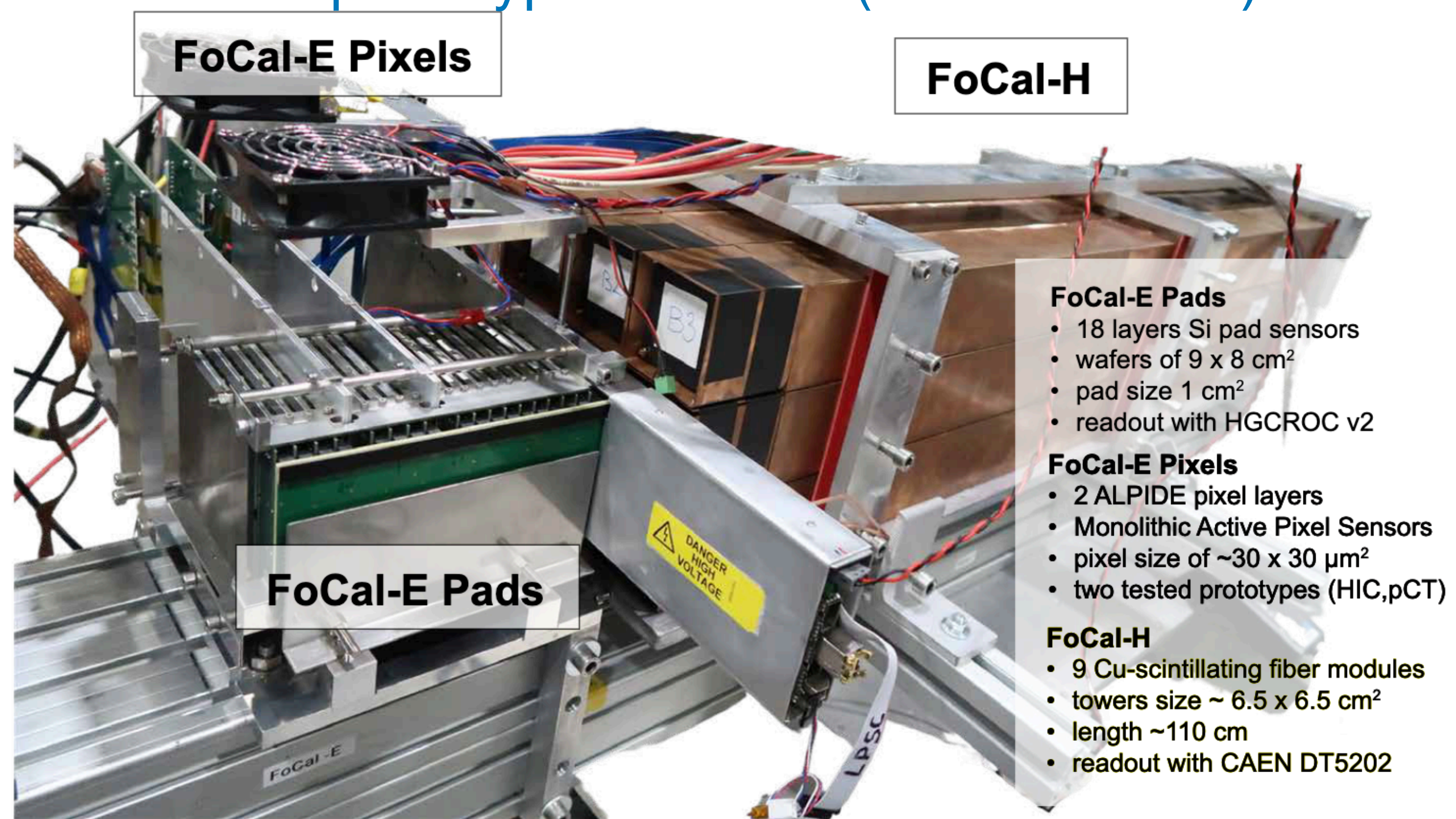

- FoCal-E Pads**
 - 18 layers Si pad sensors
 - wafers of 9 x 8 cm²
 - pad size 1 cm²
 - readout with HGCROC v2
- FoCal-E Pixels**
 - 2 ALPIDE pixel layers
 - Monolithic Active Pixel Sensors
 - pixel size of ~30 x 30 μm²
 - two tested prototypes (HIC,pCT)
- FoCal-H**
 - 9 Cu-scintillating fiber modules
 - towers size ~ 6.5 x 6.5 cm²
 - length ~110 cm
 - readout with CAEN DT5202

TDR approved [CERN-LHCC-2024-004](https://cds.cern.ch/record/2911044/files/CERN-LHCC-2024-004), [ALICE-TDR-022](https://cds.cern.ch/record/2911044/files/ALICE-TDR-022)

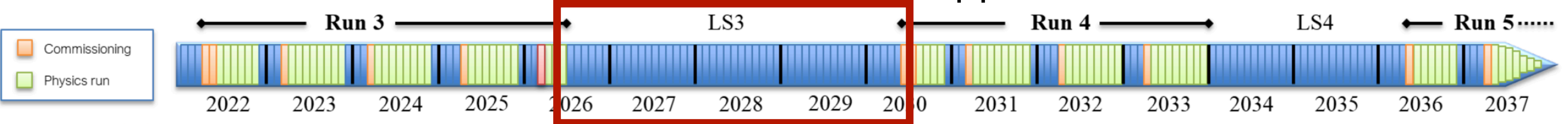

ITS3: replace the 3 inner-most vertexing layers of ALICE with ultra-light tracking layers (0.07% X_0 per layer)

Improved pointing resolution for heavy flavour reconstruction

Di-lepton measurements

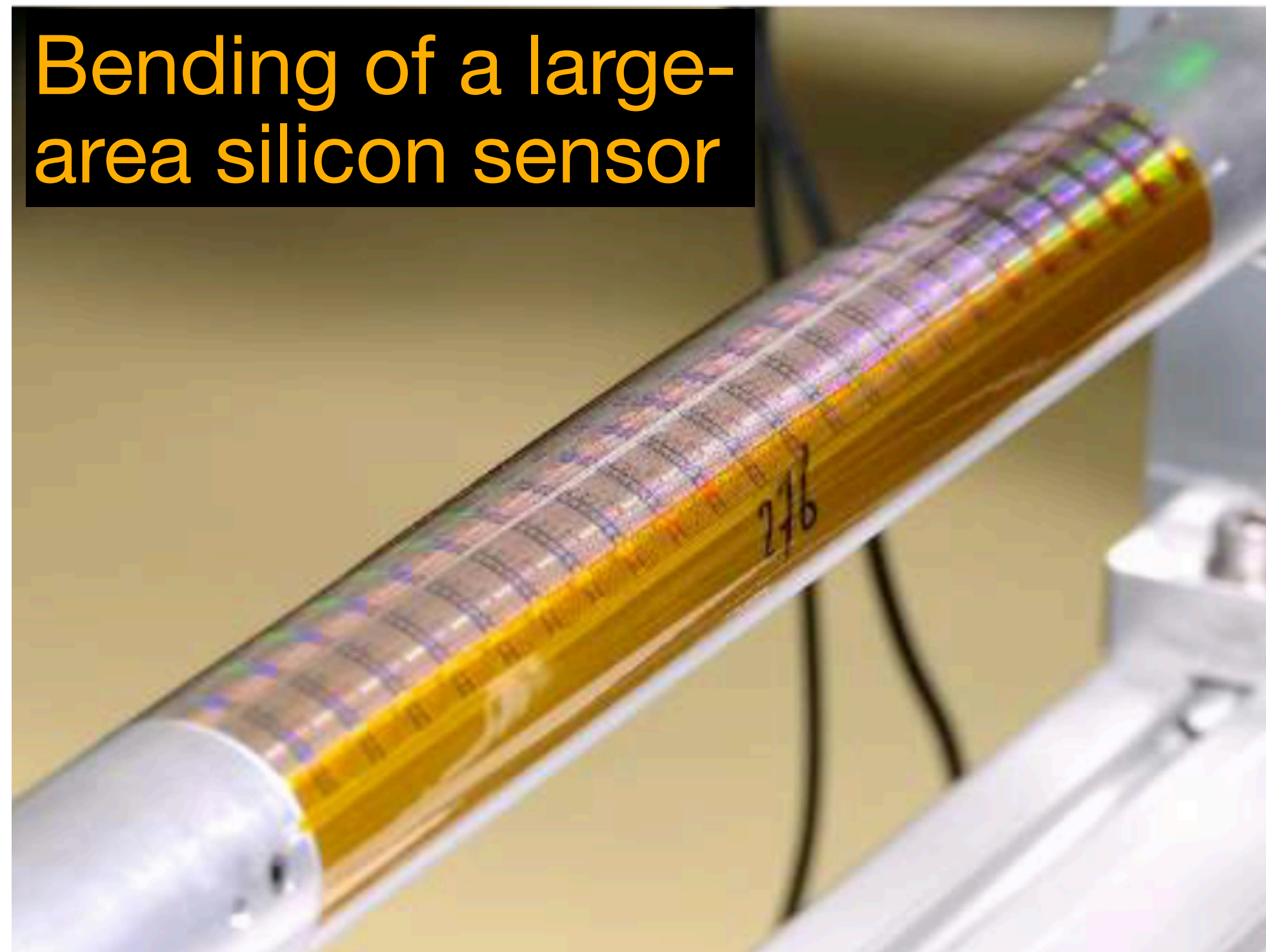
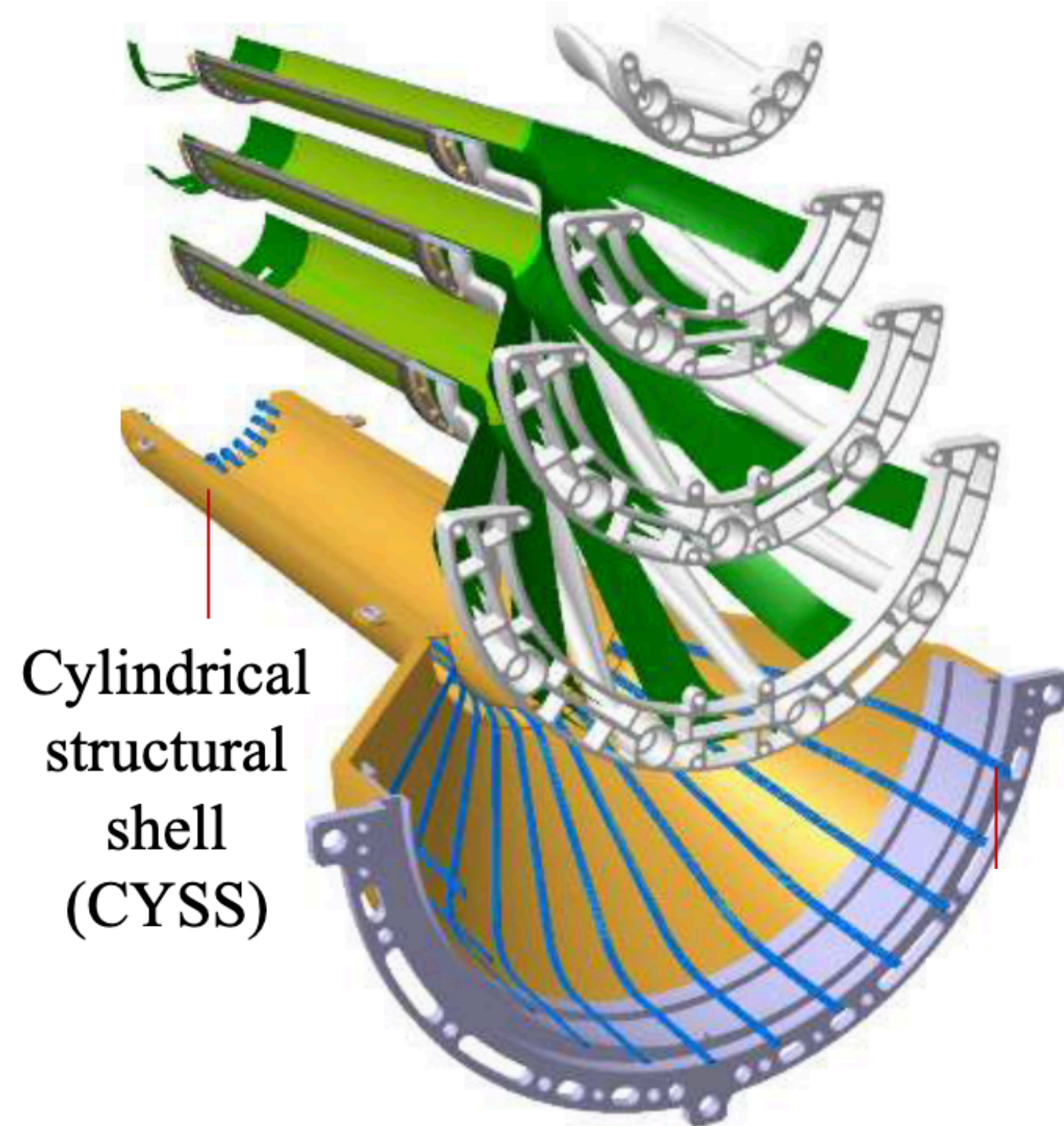

Digital pixel test structure

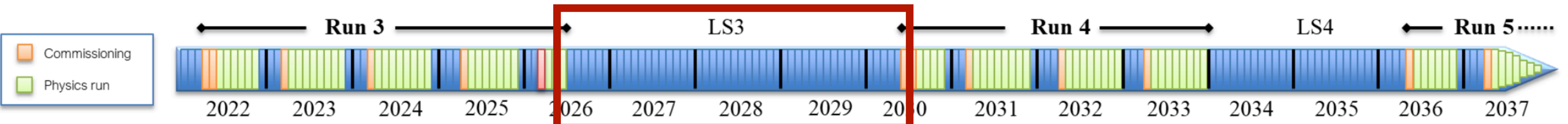
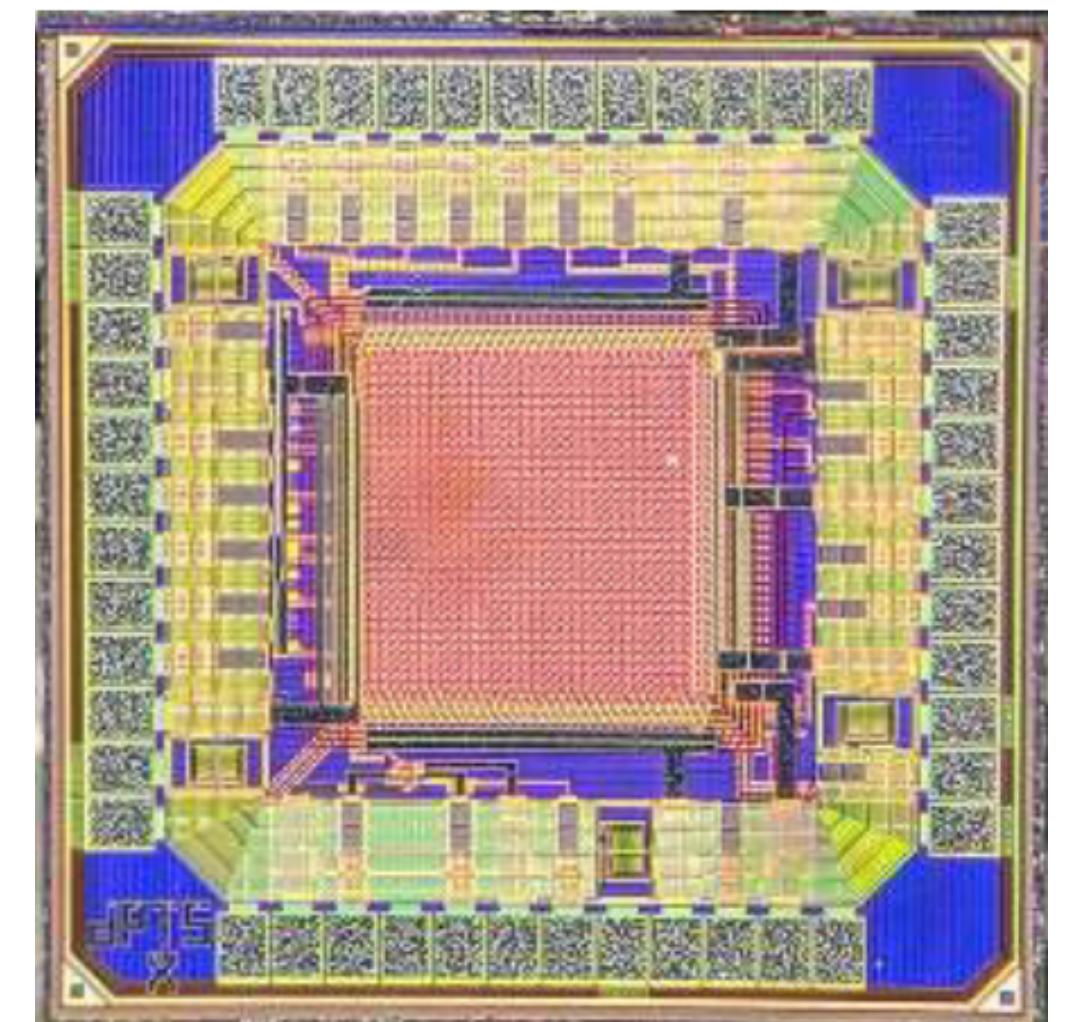

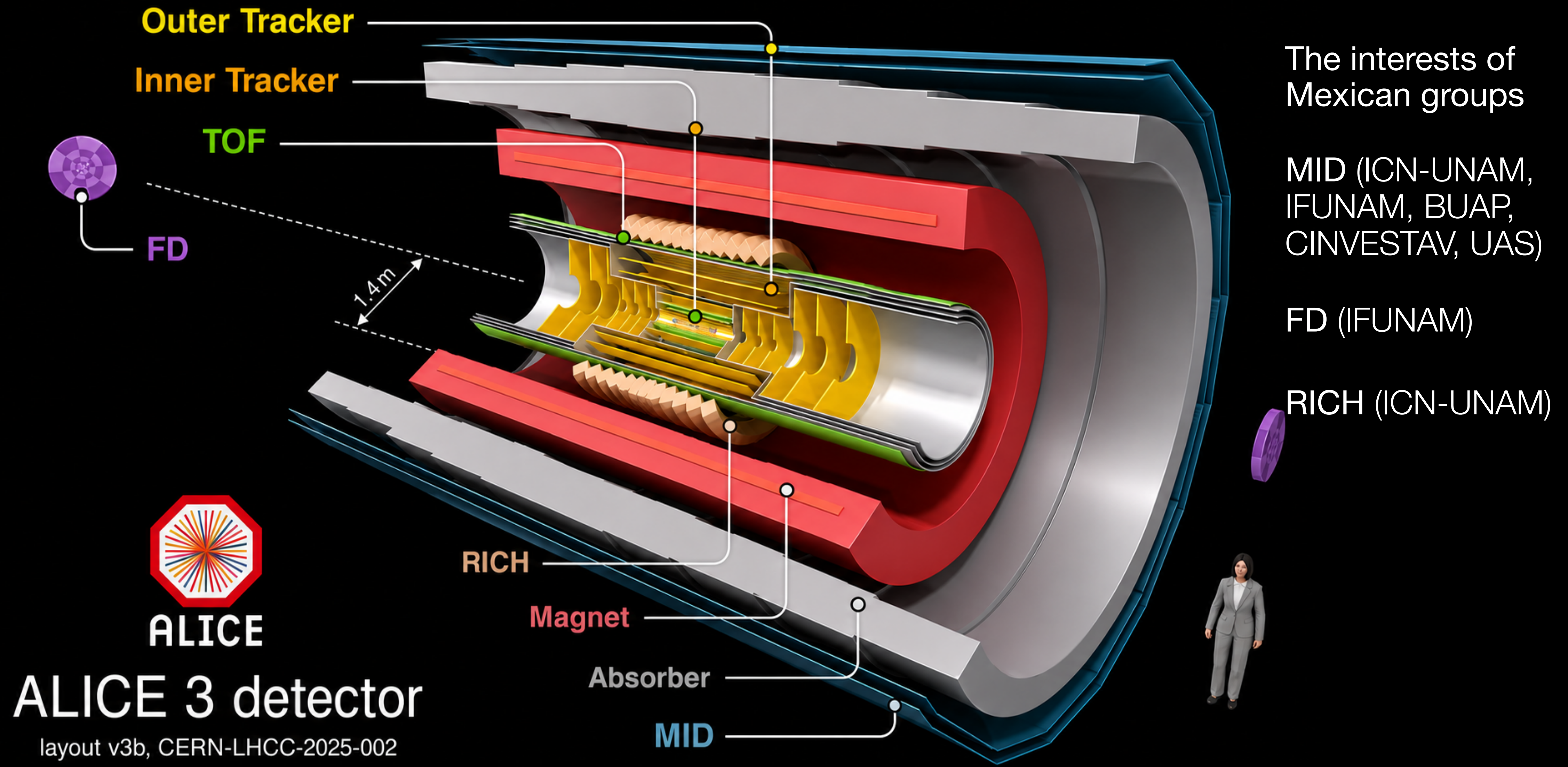

■ Commissioning
■ Physics run

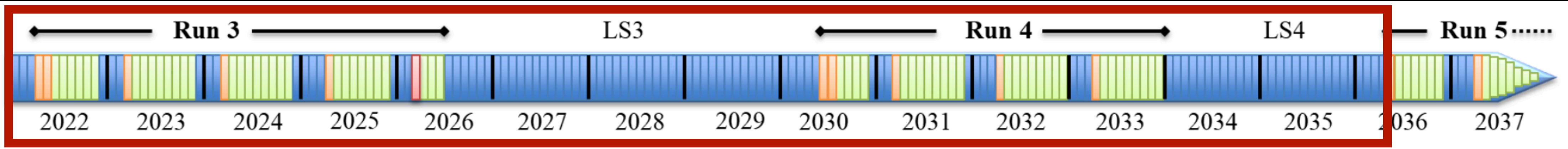

Unique ALICE 3 physics goals

Understanding thermalisation in the QGP

- degree of thermalisation of beauty: high-precision beauty measurements
- approach to chemical equilibrium: multi-charm hadrons
- direct access to charm diffusion: D-Dbar azimuthal correlations

Fundamental aspects of the QCD phase transition

- net-baryon and net-charm fluctuations
- mechanism of chiral symmetry restoration in the QGP: di-electron mass spectrum

Access to temperature as function of time

- high-precision di-electron mass spectra, p_T dependence, elliptic flow

Laboratory for hadron physics

- hadron-hadron interaction potentials
- explore nature of exotic hadrons (e.g., tetraquarks, charm-nuclei)

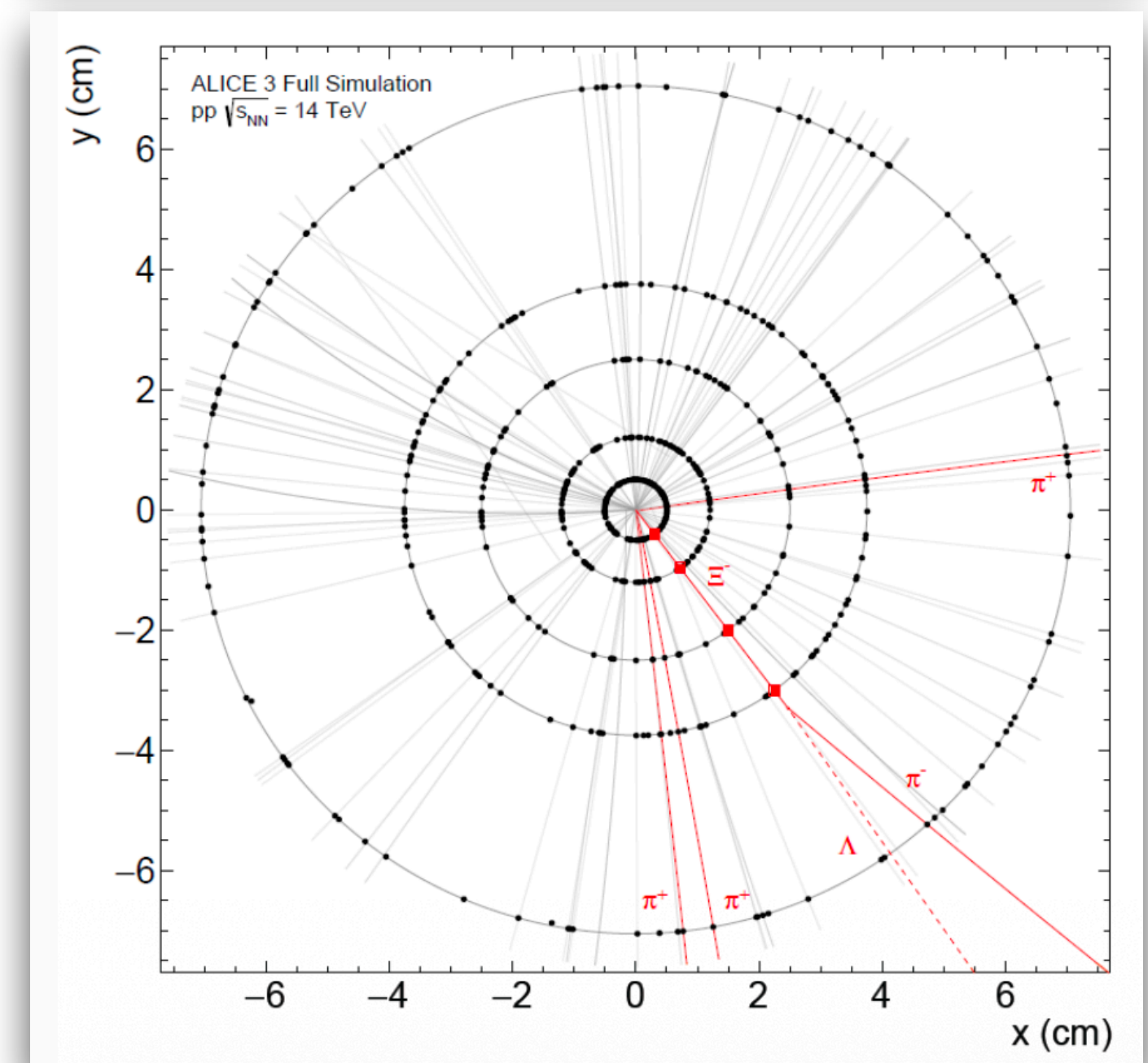
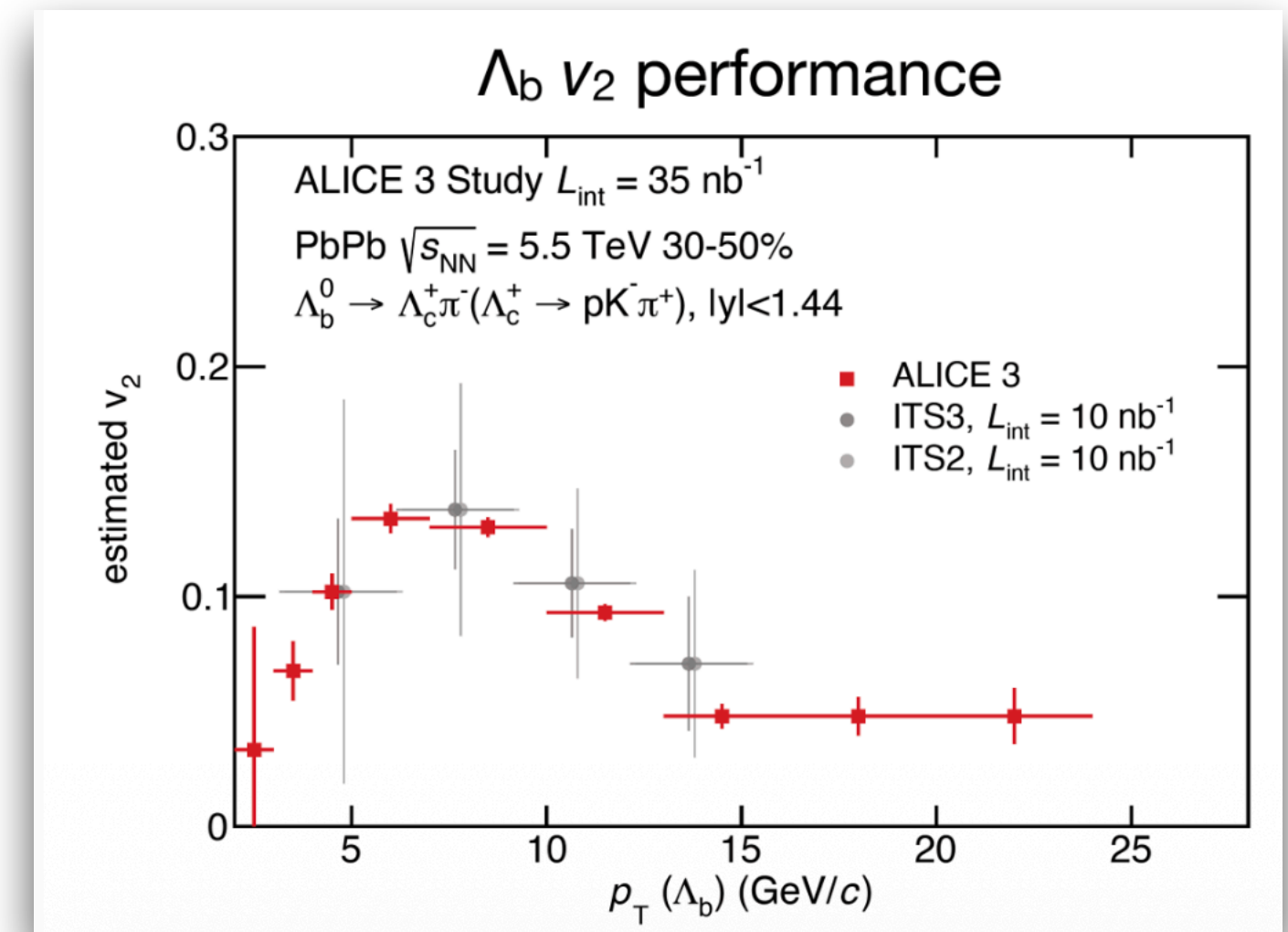

$$\Xi_{cc}^{++} \rightarrow \Xi_c^+ + \pi^+ \quad (c\tau \sim 77 \mu\text{m})$$

$$\hookrightarrow \Xi^- + 2\pi^+$$

Status of support by CERN



Mark Thomson – Director-General (Image: CERN)

M. Thomson, LHCP, 18/May/2026

The European Strategy underpins CERN's strategy

Top Priority – full exploitation of the LHC and HL-LHC

- HL-LHC and ATLAS and CMS upgrades are CERN's top priority
- Full exploitation of HL-LHC includes the ALICE and LHCb upgrades during LS4

Highest long-term priority – FCC-ee as CERN's next flagship collider

- Our aim is to be in the position for CERN Council to be from June 2028 onwards

Non-collider physics at CERN will remain an important

- Our aim is to develop a new roadmap for the future of the CERN by early 2027

Accelerator R&D – top priorities as recommended by

- Advanced superconducting and normal-conducting Radio
- Efficient RF power supplies
- Accelerator quality magnets (14-20T), including High-Ten



Scientific research

Main priorities

- **Completion of the ATLAS and CMS upgrades by 2030**
 - Alongside the HL-LHC, this is the top priority
 - To this end, CERN is strengthening the host-laboratory programme and will provide additional support to ATLAS and CMS to maximise the likelihood of success
- **Fully exploit the HL-LHC**
 - Progress the TDRs of the LS4 ALICE and LHCb upgrades and associated funding model
 - Need a plan compatible with the current LS4 schedule (2034-2035) and available funding
 - CERN is committed to investing in the Phase 2b ALICE and LHCb upgrades, and is putting in place a provisional budget line for host-laboratory support
- **Evolve the computing for the HL-LHC operation**
 - Working with the LHC collaborations and the WLCG to evolve the computing model for HL-LHC operation within the likely available resources



Organization

Subsystems:

Inner Tracker: → **Project**: PL J. Klein (CERN), dPL S. Piano (Trieste)

Outer Tracker: → **Project**: PL L. Fabbietti (Munich), dPLs MJ. Kweon (Inha), M. van Leeuwen (Nikhef)

Tracker MAPS sensor (ALMIRA):

→ **Joint Technical Project** (IT, OT): PLs G. Aglieri Rinella, M. Mager, W. Snoeys (CERN)

TOF Detector: → **Project**: PL A. Rivetti (Torino), dPLs S. Bufalino (Torino), G. Scioli (Bologna)

RICH Detector WG: G. Volpe (Bari)

MID Detector WG: A. Ortiz (Mexico City)

migrating to Project, A. Ortiz nominated as PL

TDR starting this summer

Forward Detector WG: J. Otwinowski (Krakow)

Data flow and online processing WG: V. Barroso (CERN), D. Rohr (CERN), T. Kollegger (Frankfurt)

Simulation and Physics Studies: N. Jacazio (UniPO), P. Butti (Nikhef)

Contacts for general items and other activities:

Magnet, general infrastructure, integration: TC - W. Riegler, A. Tauro, A. Foussat, C. Gargiulo, E. Laudi

Detector readout, links: EC - A. Kluge, F. Costa (CERN)

MID: the first Mexican PID detector for ALICE

MID

Ian Pérez (BS thesis)

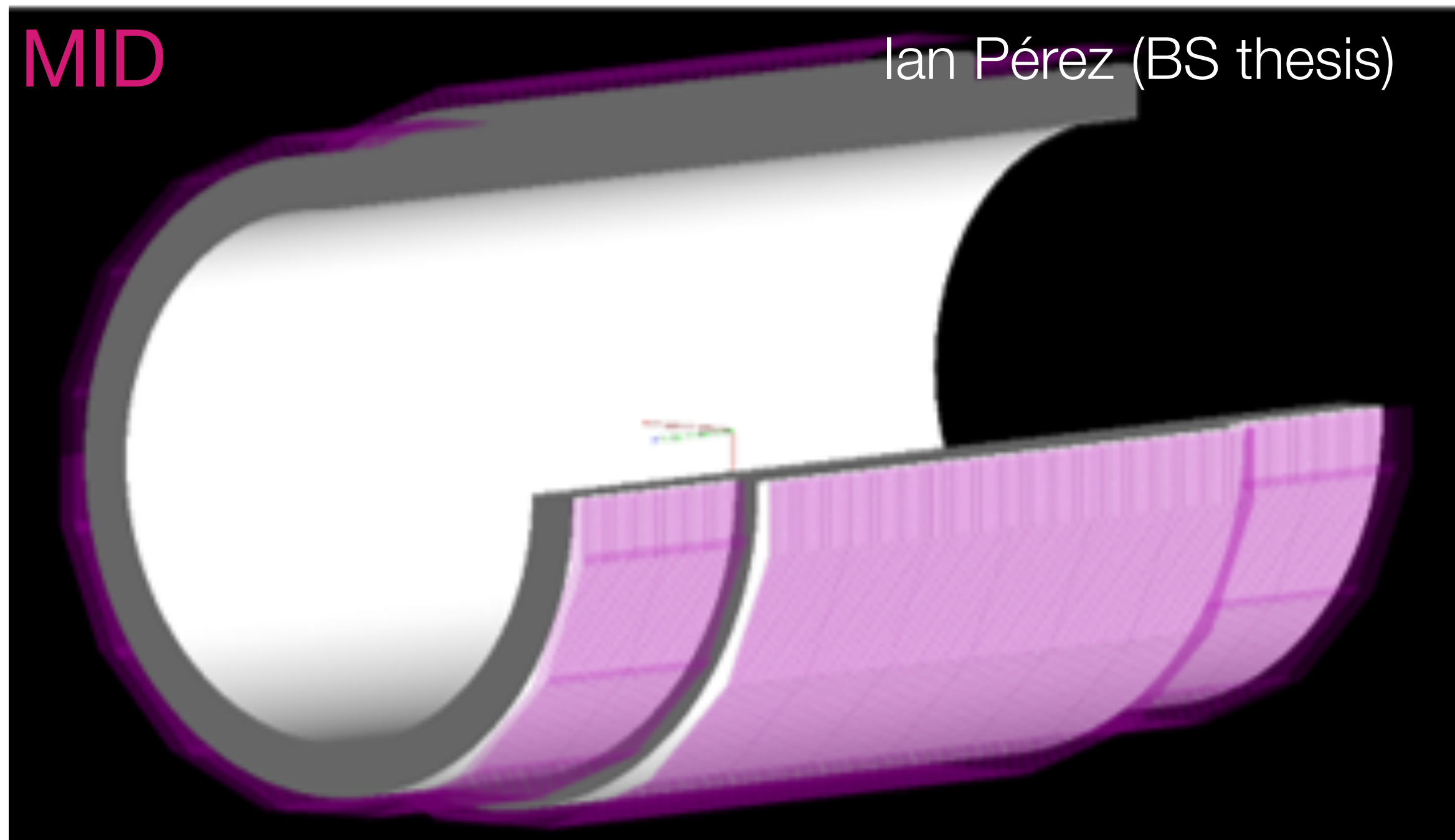

Goal: reconstruct J/ψ from $p_T=0$ in the di-muon decay channel, $p > 1.5$ GeV/c

- Standard magnetic iron absorber, ~ 4 hadronic absorption lengths
- The absorber is followed by MID chambers ($|y| < 1.25$)
- Scintillator-based chambers (each channel: $100 \times 5 \times 1$ cm³ scintillator bar equipped with WLS fiber and readout with SiPM) [baseline option]

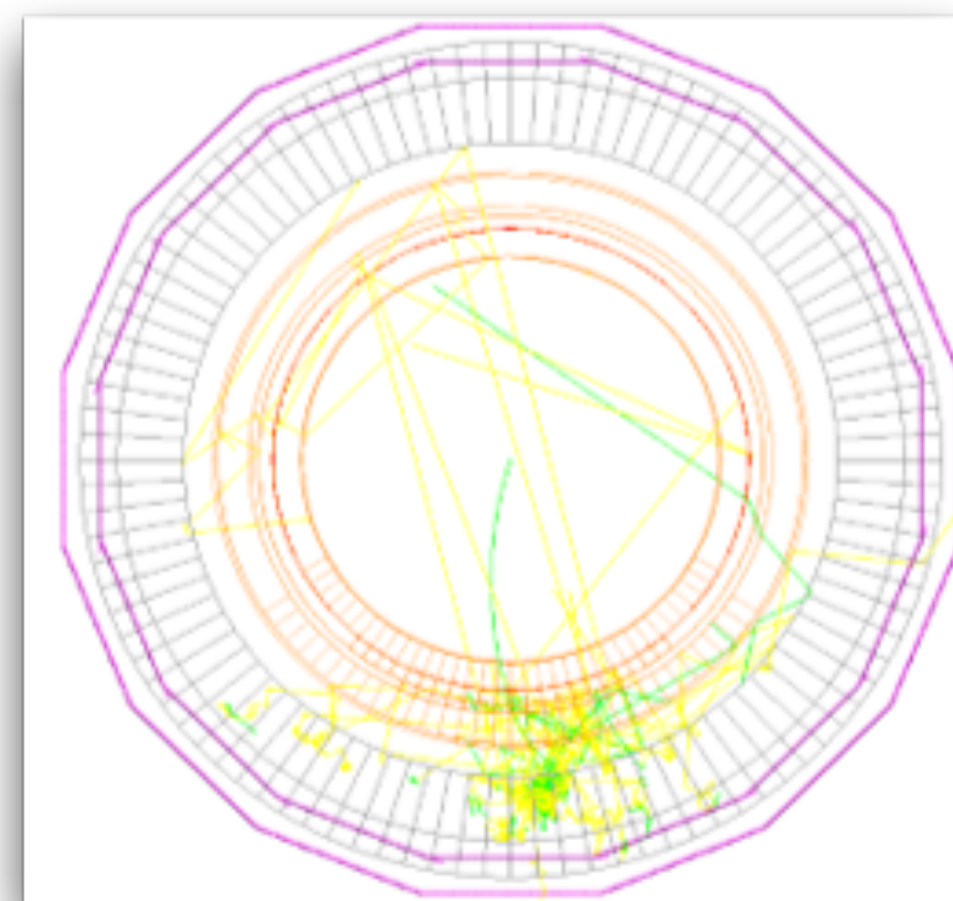
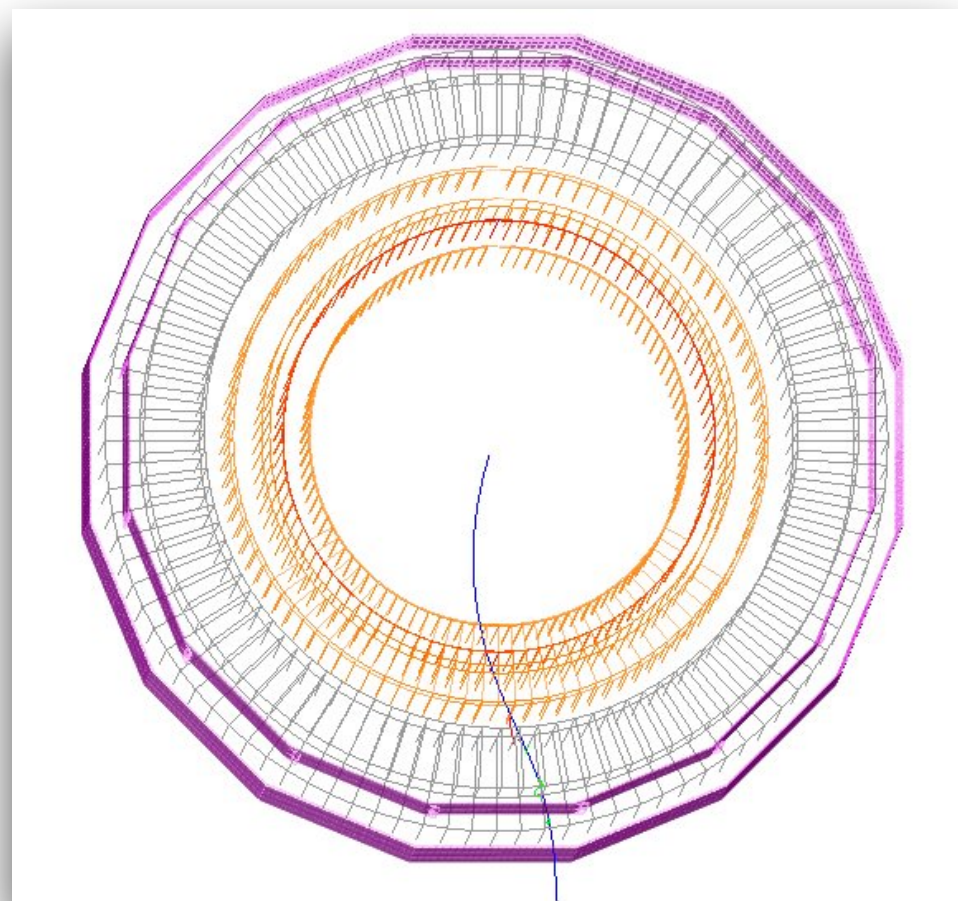

Cz. Rep., Hungary, Mexico, Pakistan, US-NSF

MID: the first Mexican PID detector for ALICE

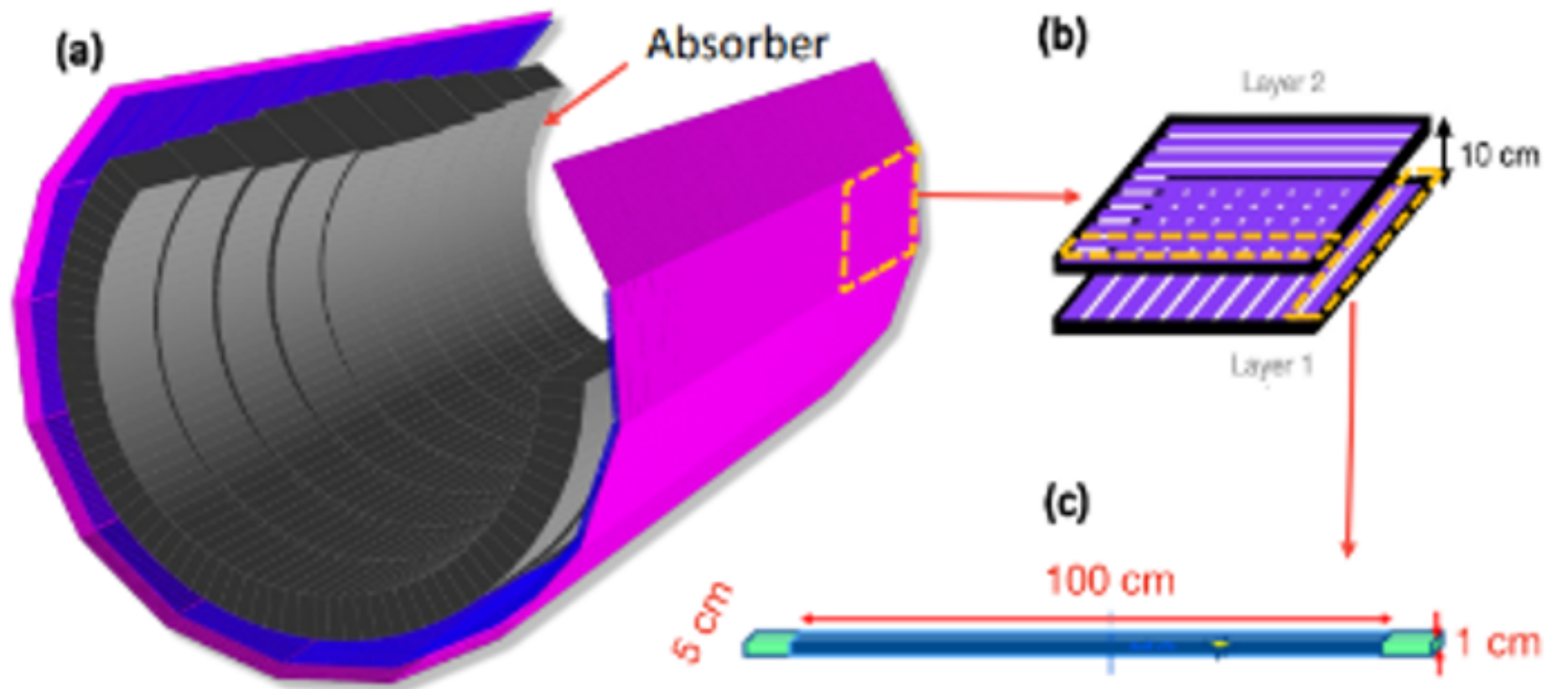

Modular design, ~200 muon chambers covering a detection area of 180 m² / AI-enhanced technology

~10,000 channels (scintillators coupled to solid-state photodetectors)

MID: the first Mexican PID detector for ALICE

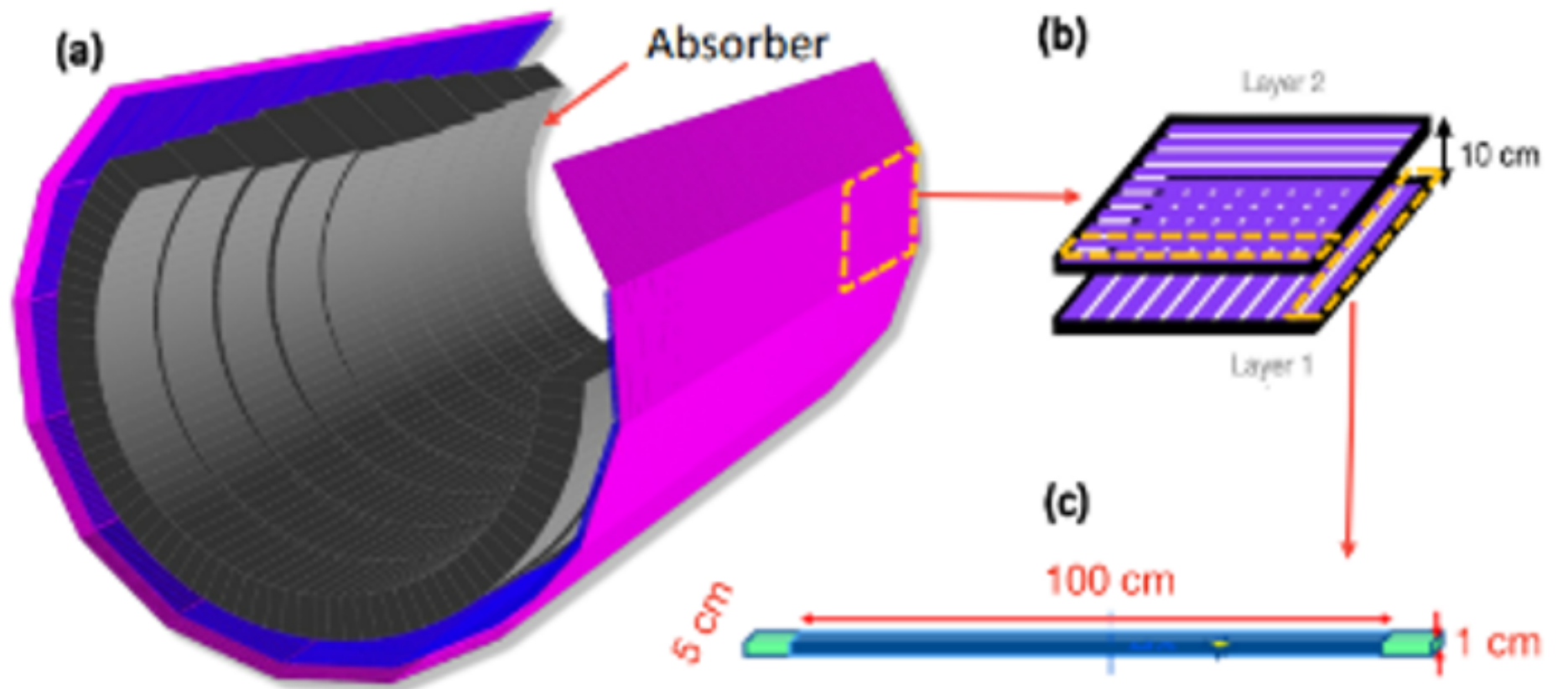

~10,000 channels (scintillators coupled to solid-state photodetectors)

Modular design, ~200 muon chambers covering a detection area of 180 m² / AI-enhanced technology

Ultra-fast electronics capable of taking data at an interaction rate of 24MHz (pp)

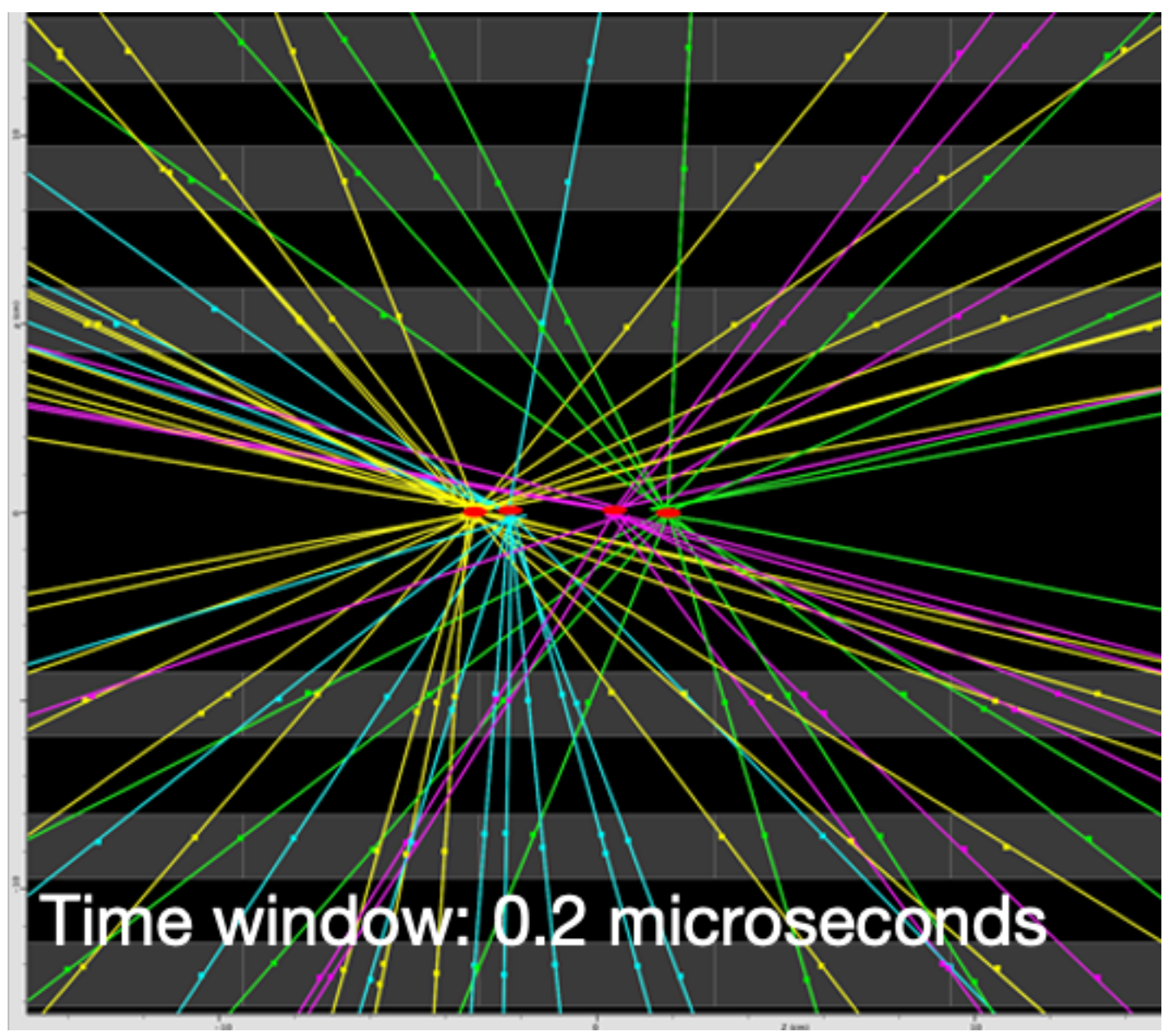

Time window: 0.2 microseconds

MID: the first Mexican PID detector for ALICE

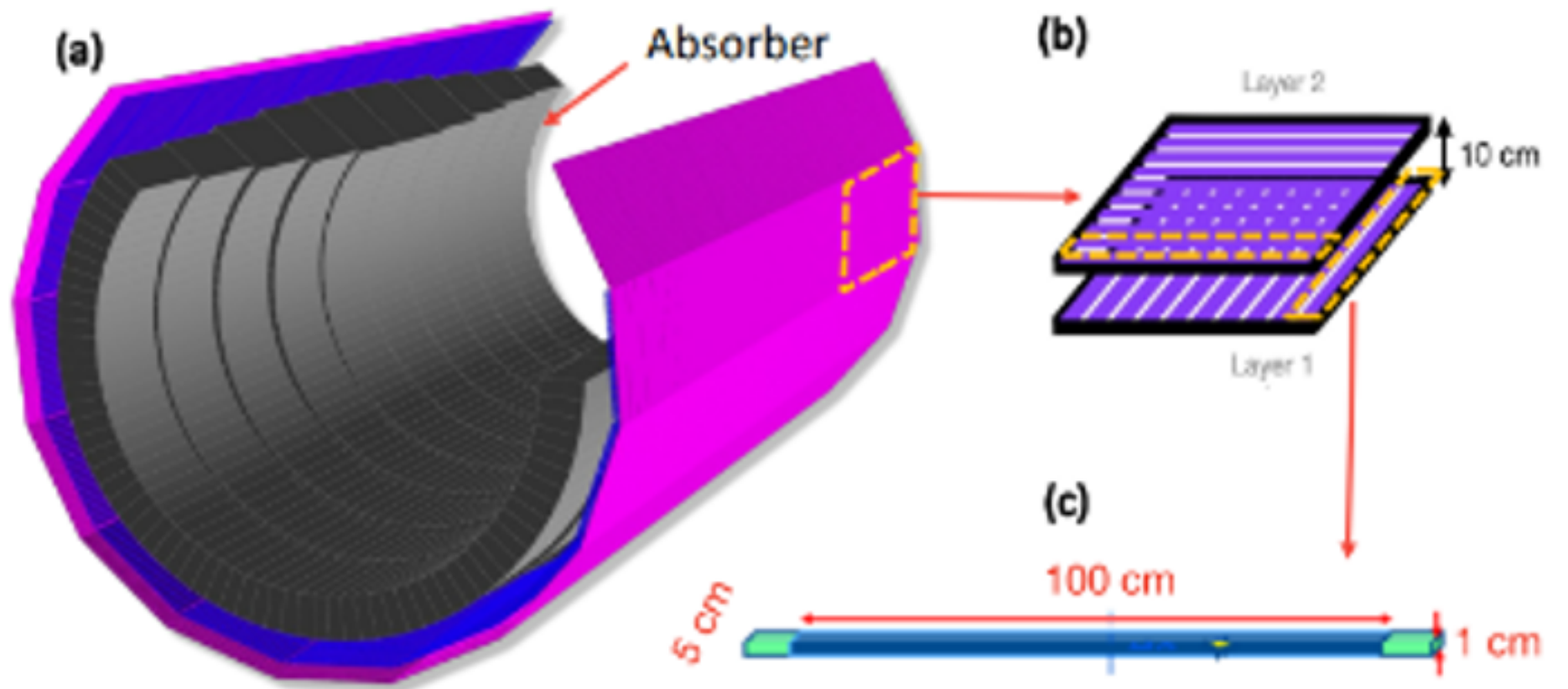

~10,000 channels (scintillators coupled to solid-state photodetectors)

Modular design, ~200 muon chambers covering a detection area of 180 m² / AI-enhanced technology

Ultra-fast electronics capable of taking data at an interaction rate of 24MHz (pp)

Development of Mexican scintillator materials

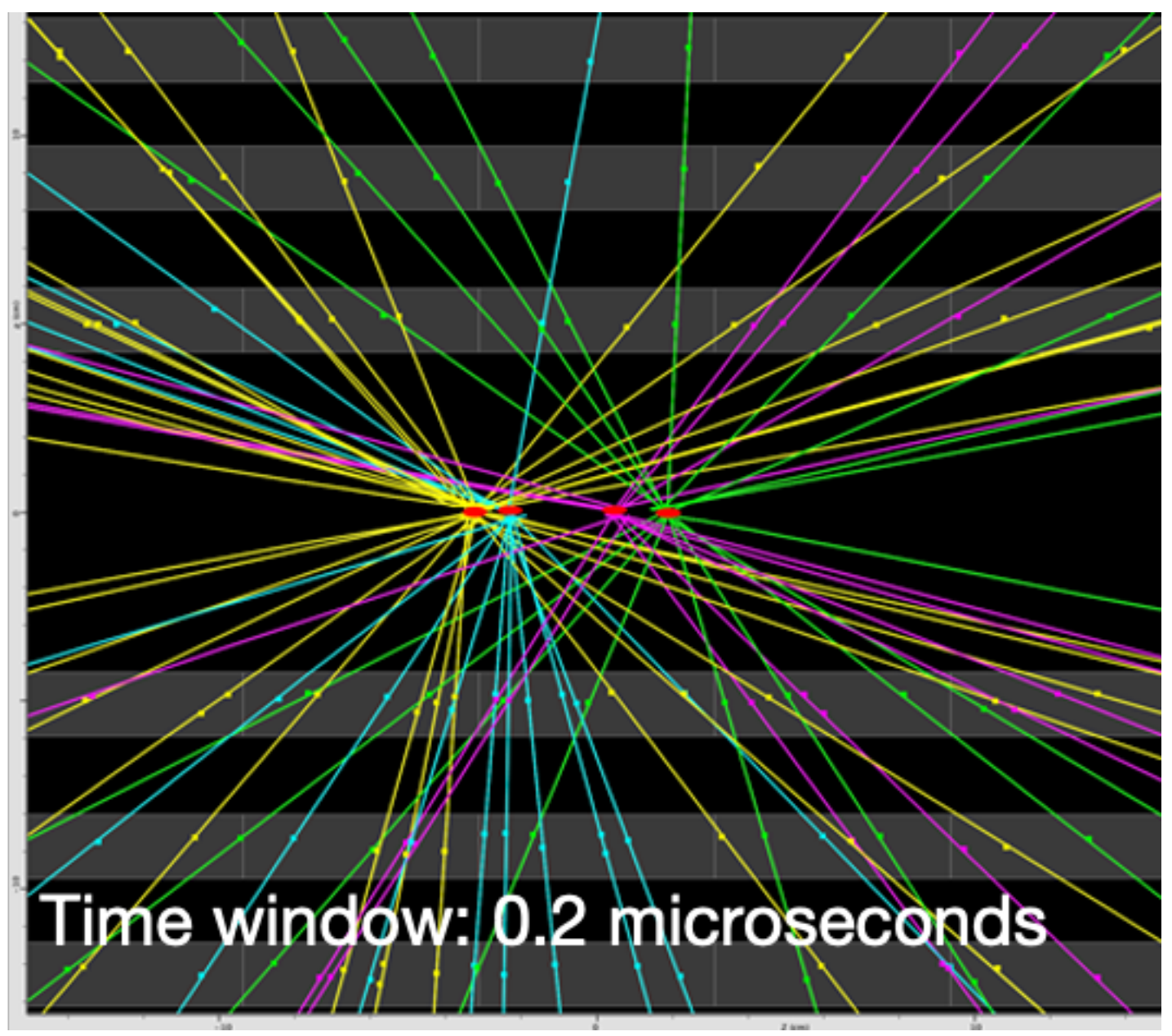

MID: the first Mexican PID detector for ALICE

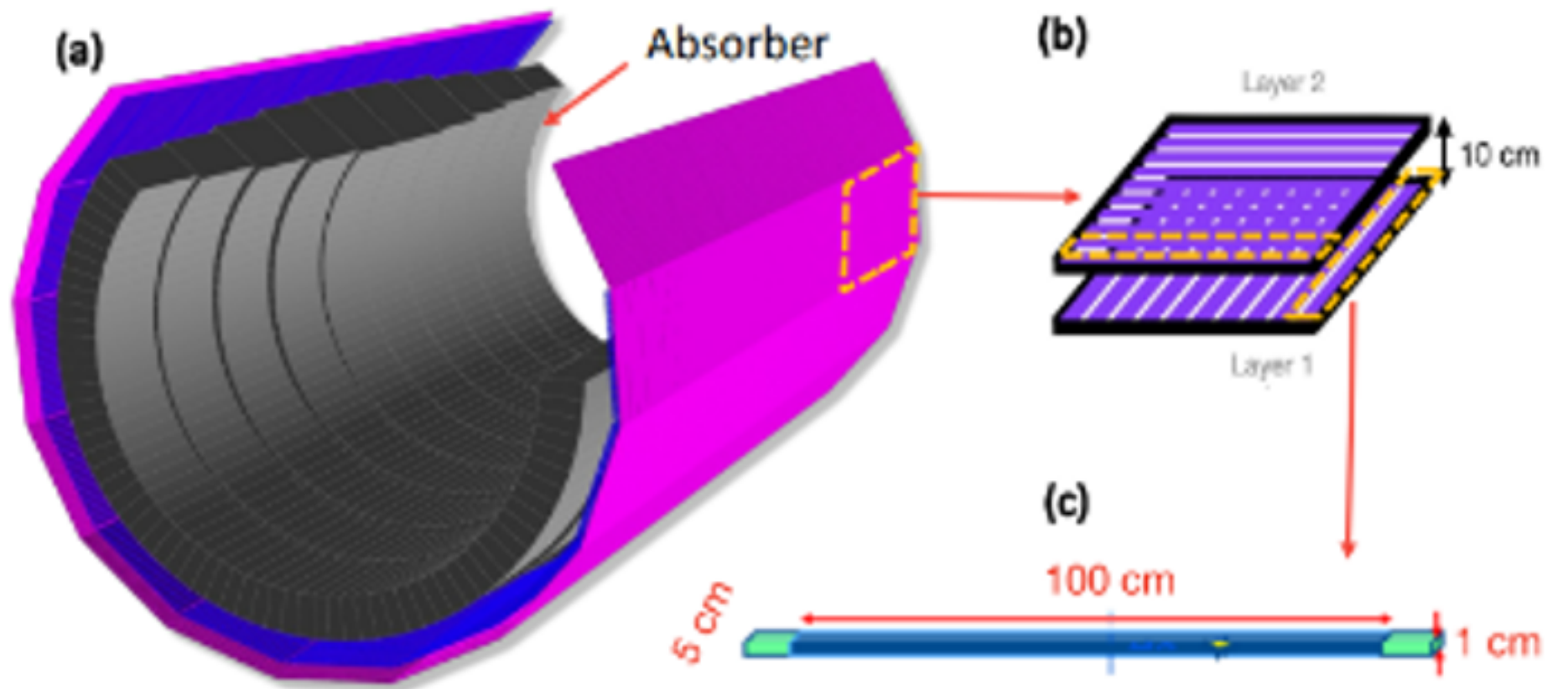

~10,000 channels (scintillators coupled to solid-state photodetectors)

Modular design, ~200 muon chambers covering a detection area of 180 m² / AI-enhanced technology

Ultra-fast electronics capable of taking data at an interaction rate of 24MHz (pp)

Development of Mexican scintillator materials

Detector control system / absorber design

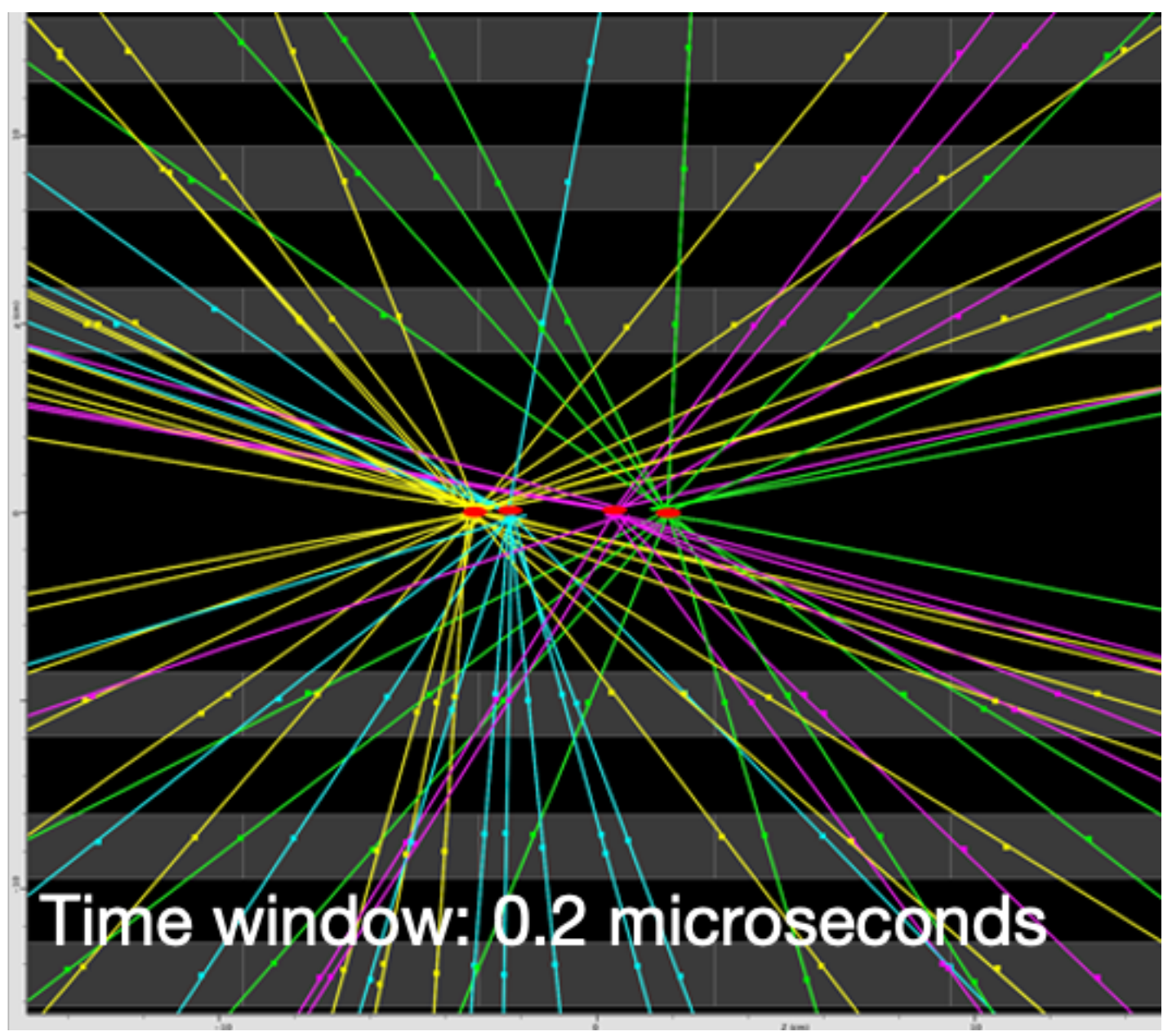

Beam test 2023

MS: Marco Antonio Diaz Maldonado (2024)

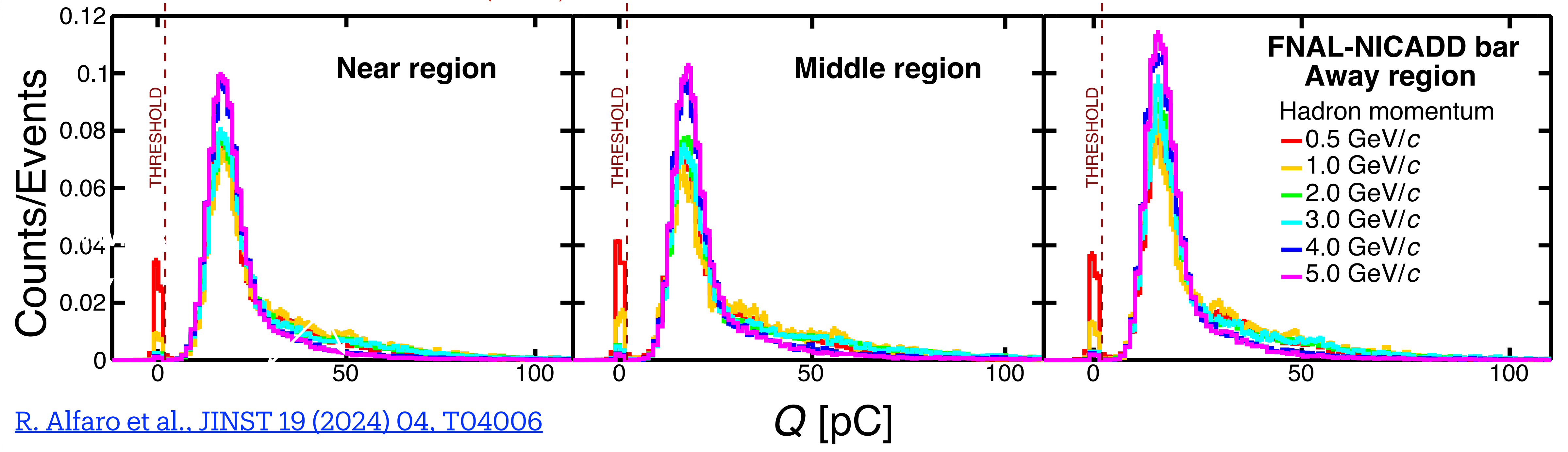

[R. Alfaro et al., JINST 19 \(2024\) 04, T04006](#)

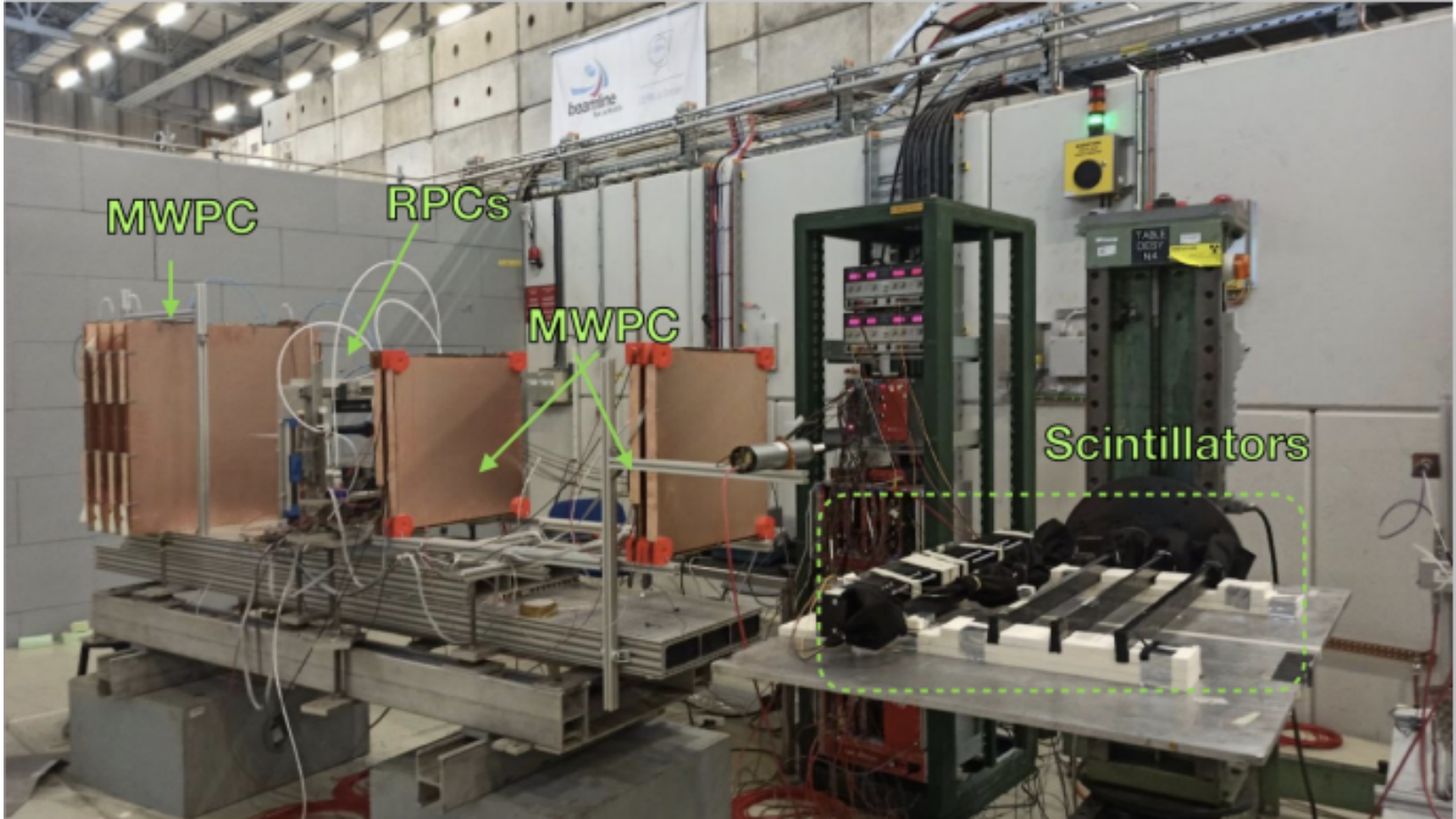

- ◆ Low-cost plastic scintillator equipped with WLS fiber: high and uniform efficiency along the bar (1 m length)
- ◆ Excellent separation between signal and pedestal. About 40 p.e. are measured for MIP (insensitive to dark count rate)

Beam test 2024

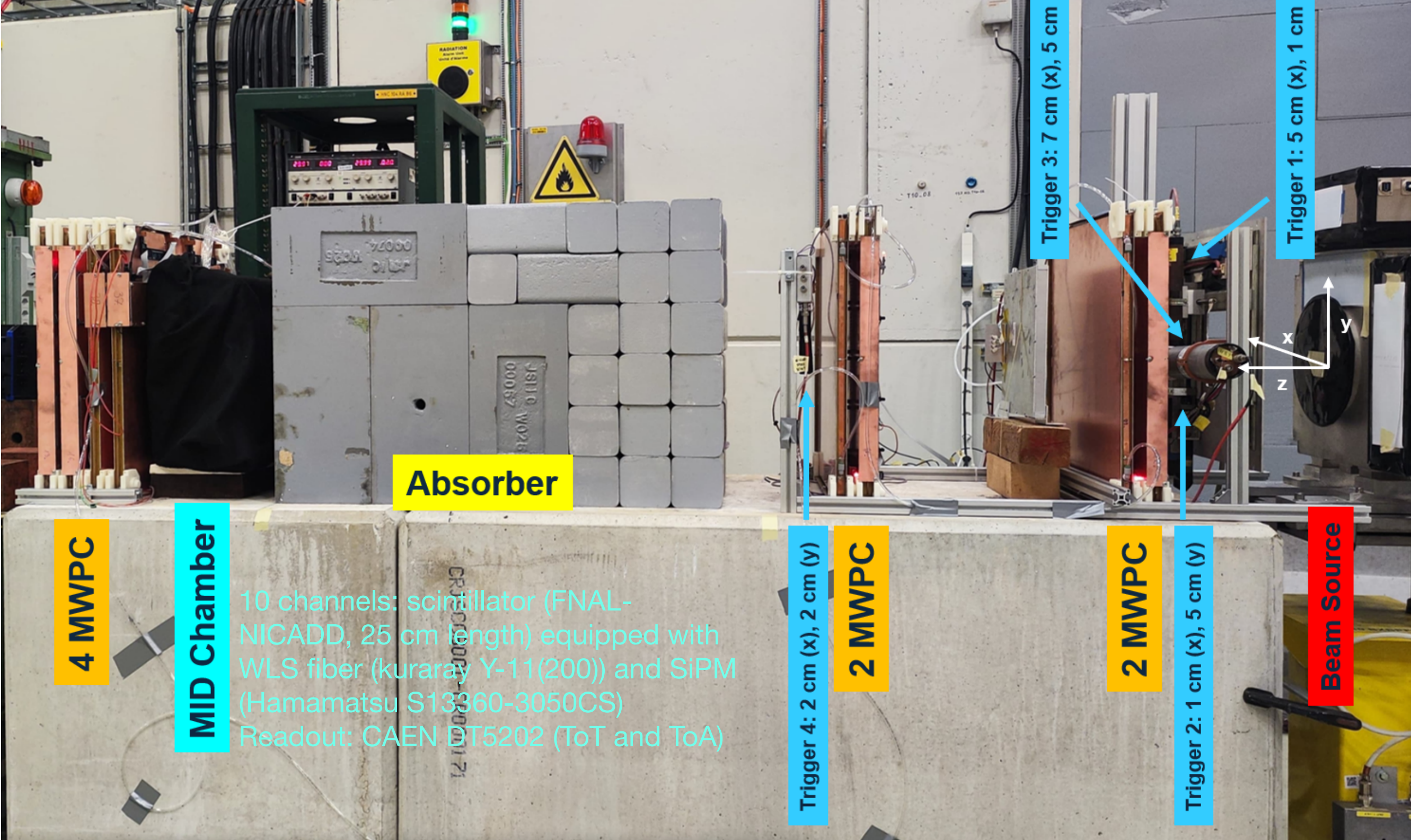

All hits

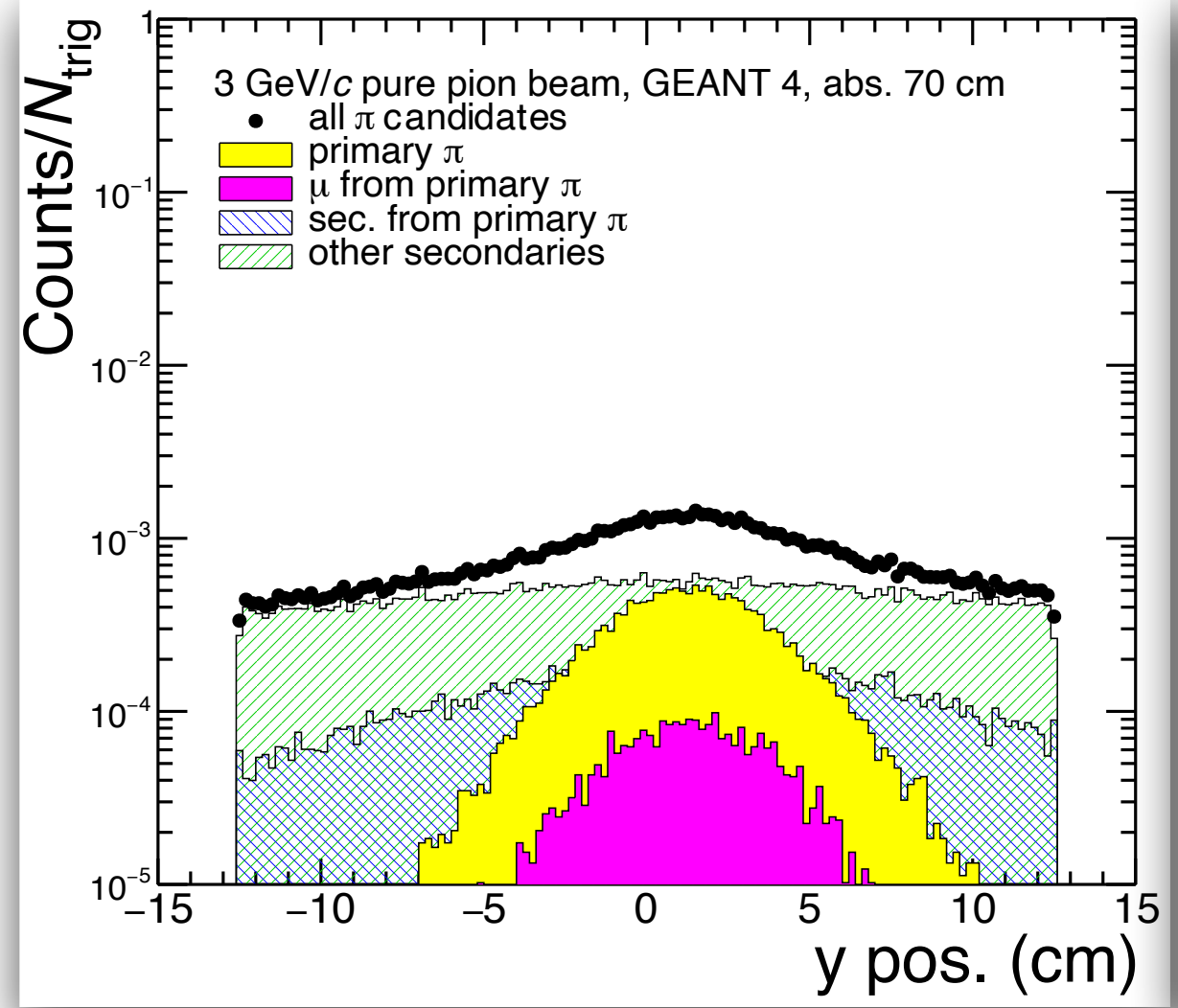

Time selection

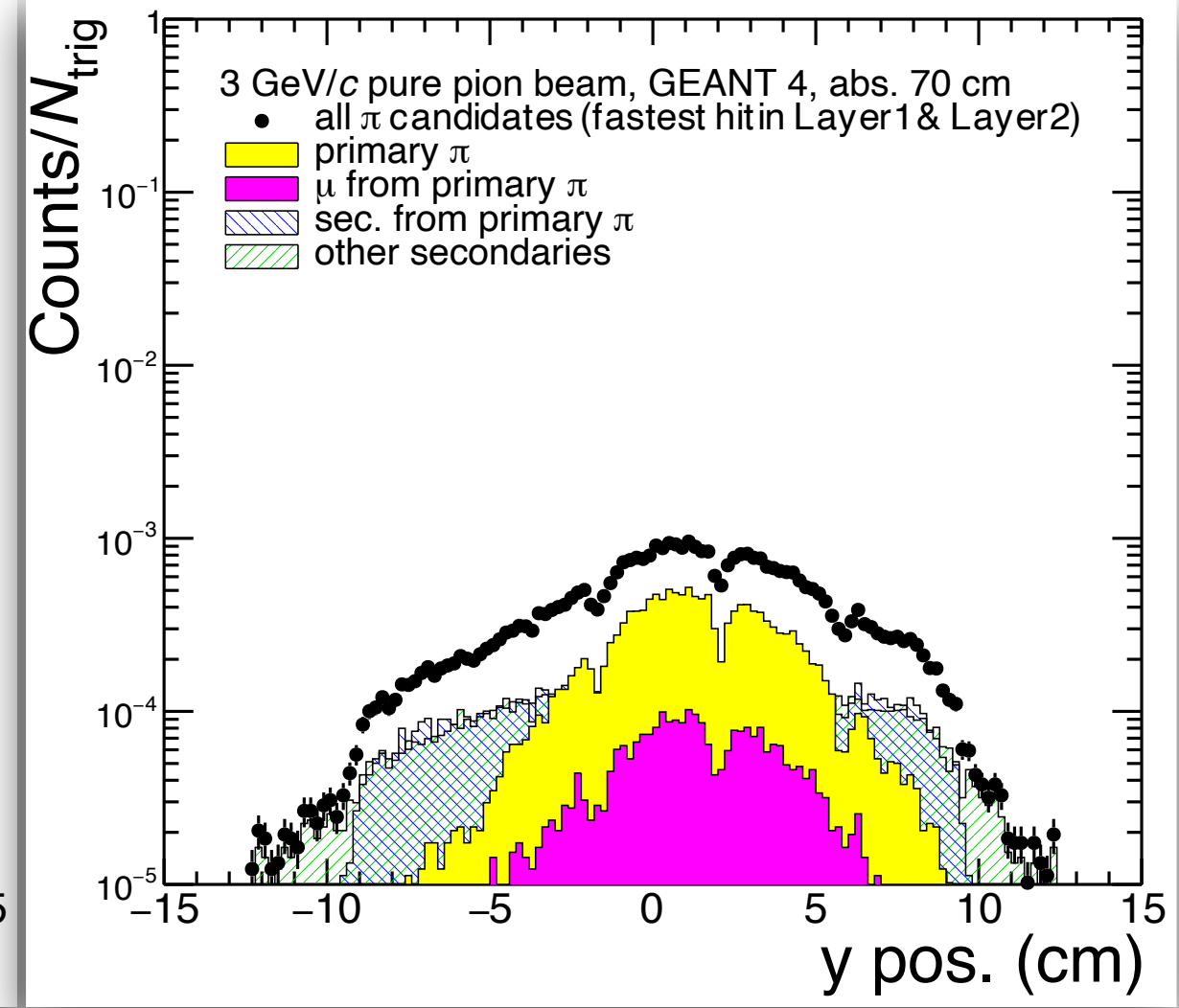

PAPER • OPEN ACCESS

ML-based muon identification using a FNAL-NICADD scintillator chamber for the MID subsystem of ALICE 3

Jesús Eduardo Muñoz Méndez, Antonio Ortiz, Antonio Paz, Paola Vargas Torres, Ruben Alfaro Molina, Laura Helena González Trueba, Varlen Grabski, Arturo Fernández Téllez, Hector David Regules Medel, Mario Rodríguez Cahuantzi, Guillermo Tejeda Muñoz, Yael Antonio Vásquez Beltran, Juan Carlos Cabanillas Noris, Solangel Rojas Torres, Gergely Gábor Barnaföldi, Dániel Száraz, Dezső Varga, Róbert Vértesi and Edmundo García Solís

Published 10 September 2025 • © 2025 The Author(s)

Journal of Instrumentation, Volume 20, September 2025

Citation Jesús Eduardo Muñoz Méndez et al 2025 JINST 20 P09015

DOI 10.1088/1748-0221/20/09/P09015

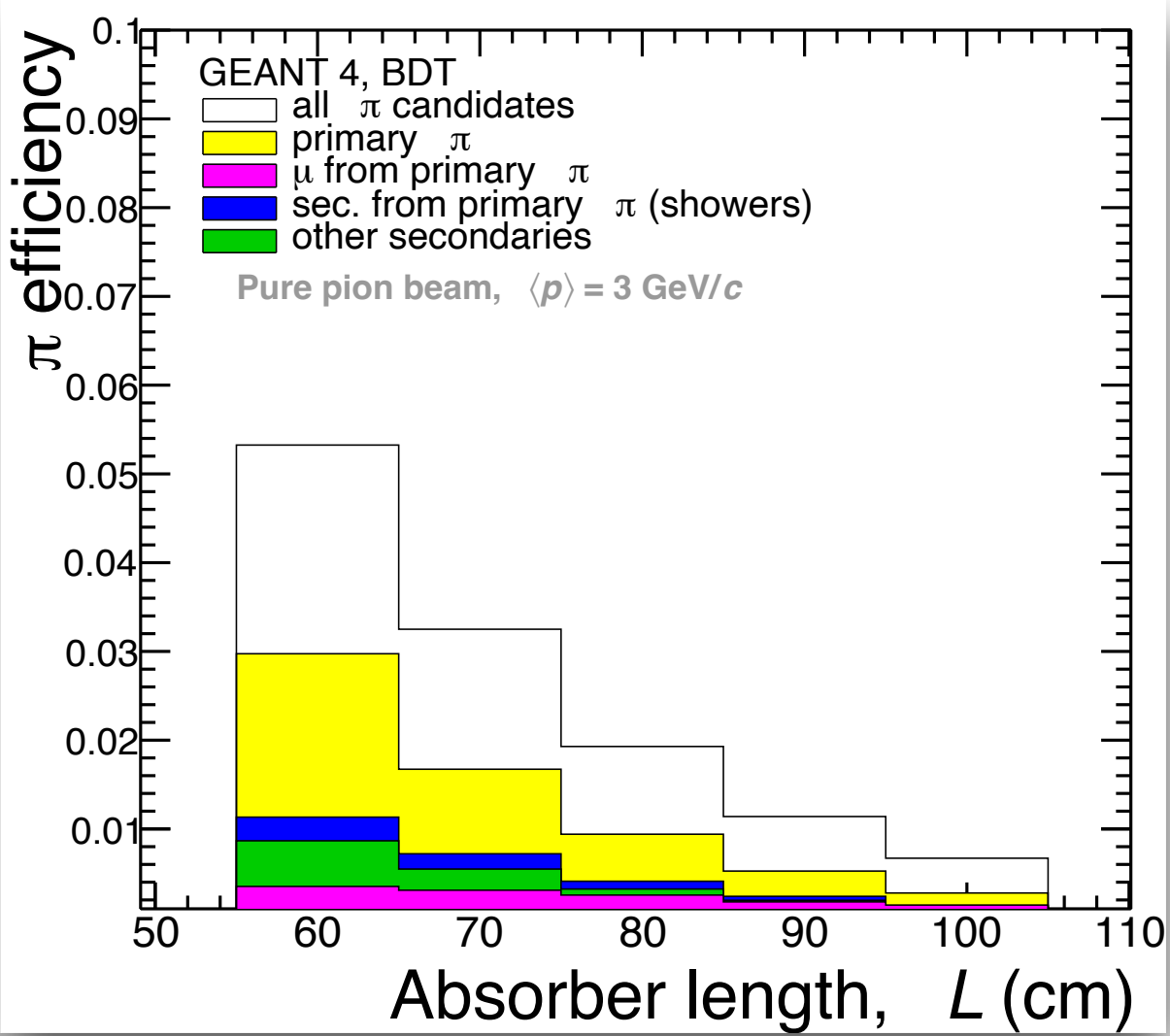
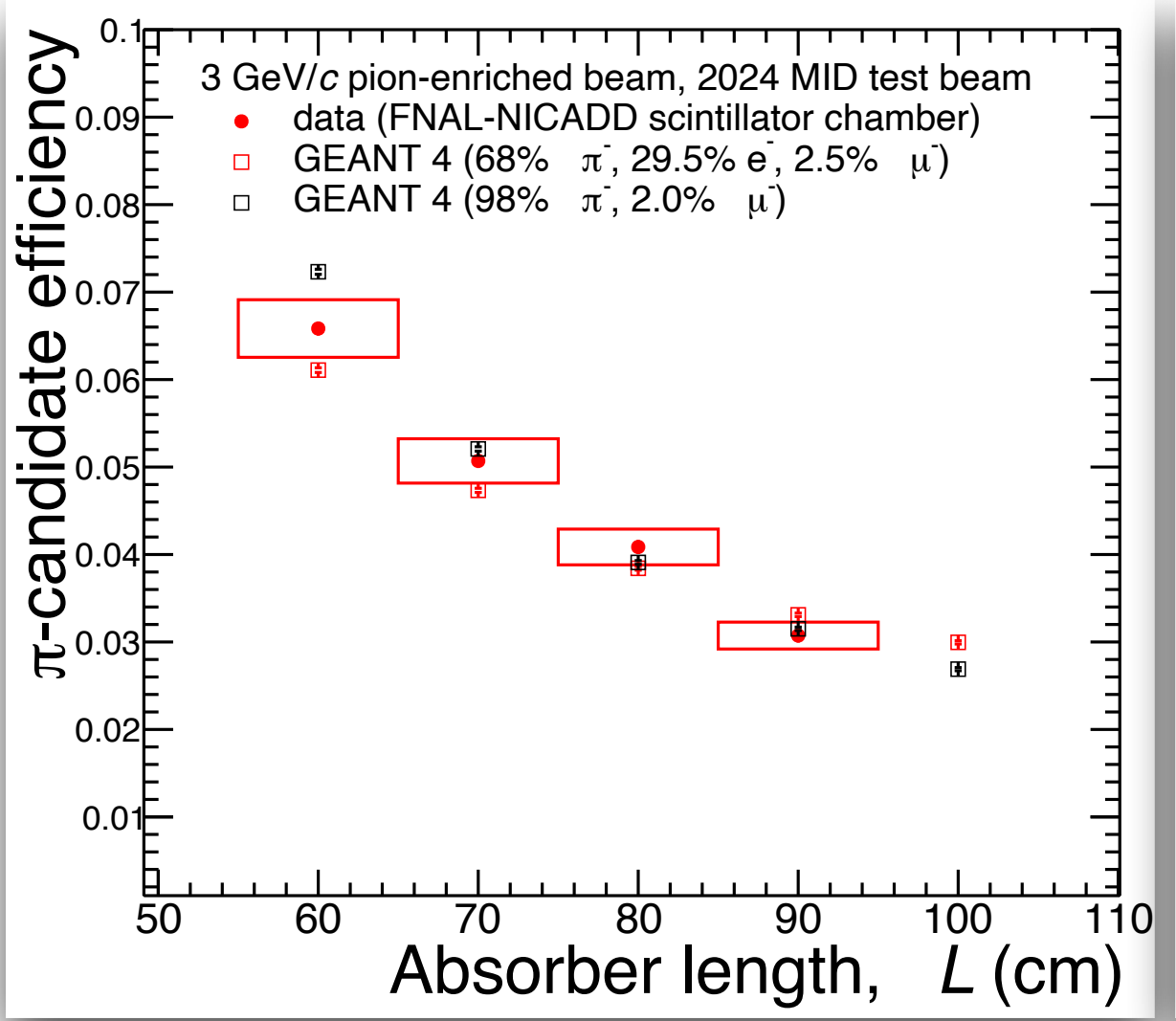

Beam test 2025

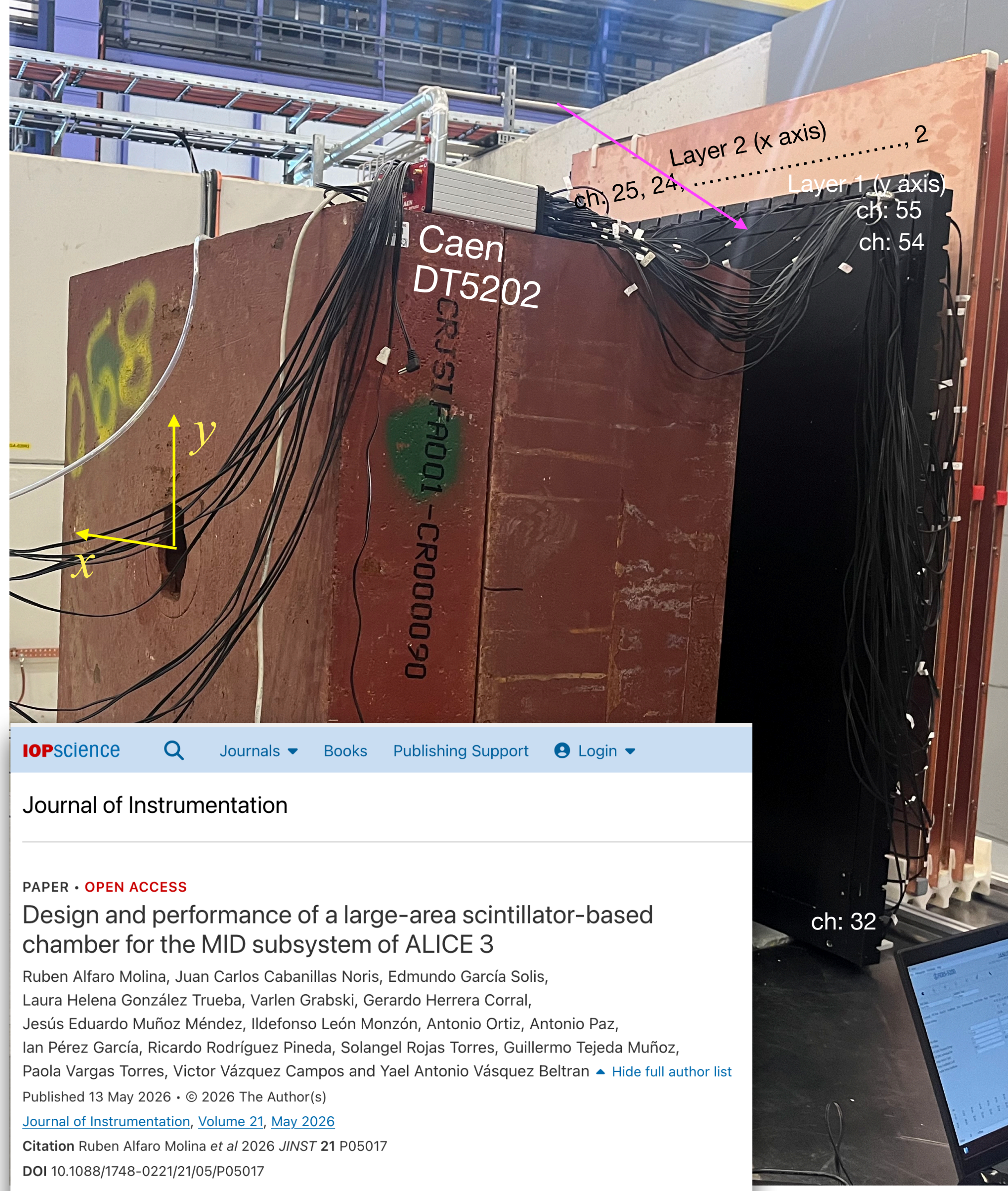

- 48 channels (<1mm bar spacing): FNAL scintillator bar + Kuraray WLS fiber + SiPMs (S14160-3050HS). Data acquisition: caen DT5202

- Version 1 of FEC was tested

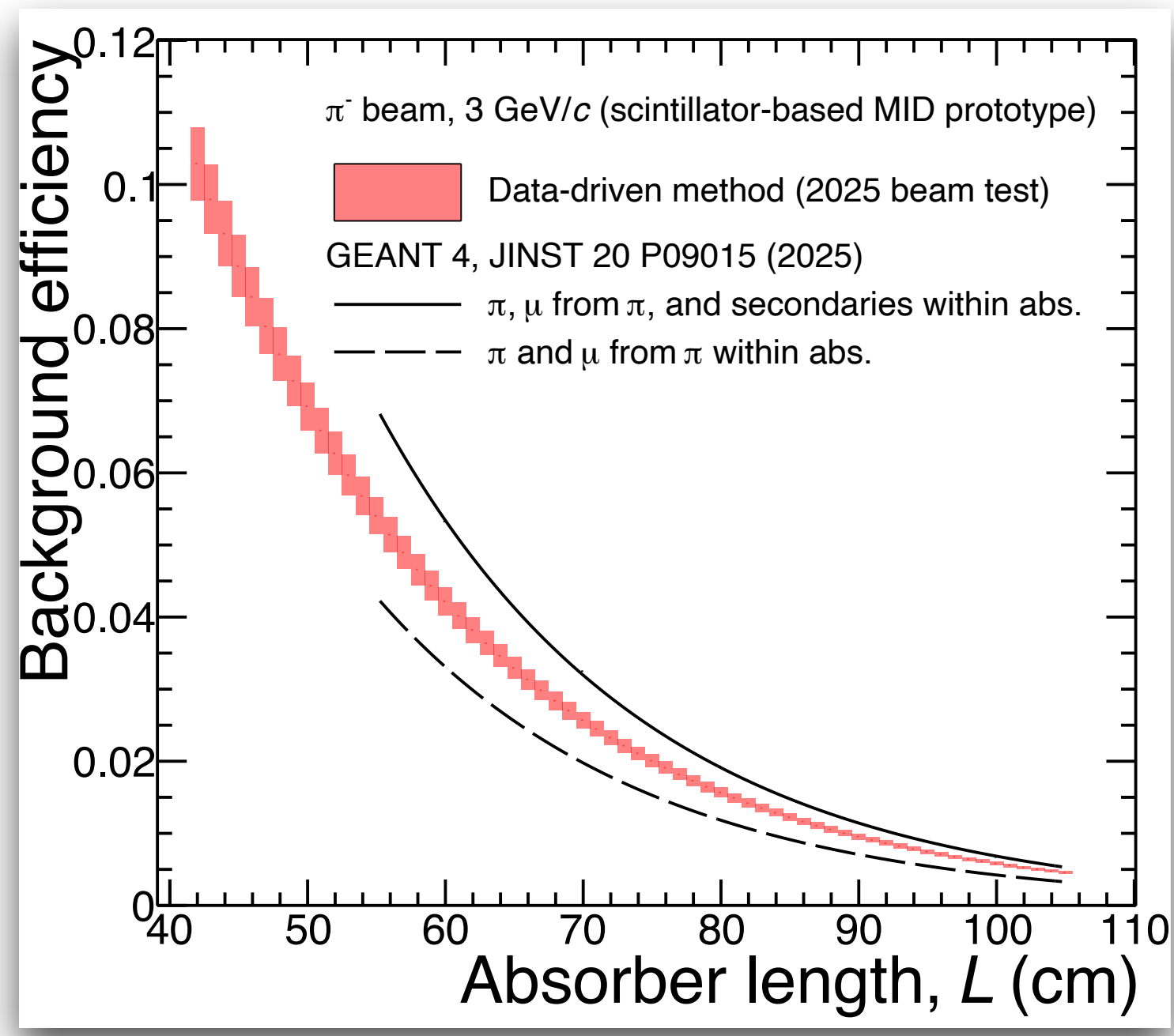
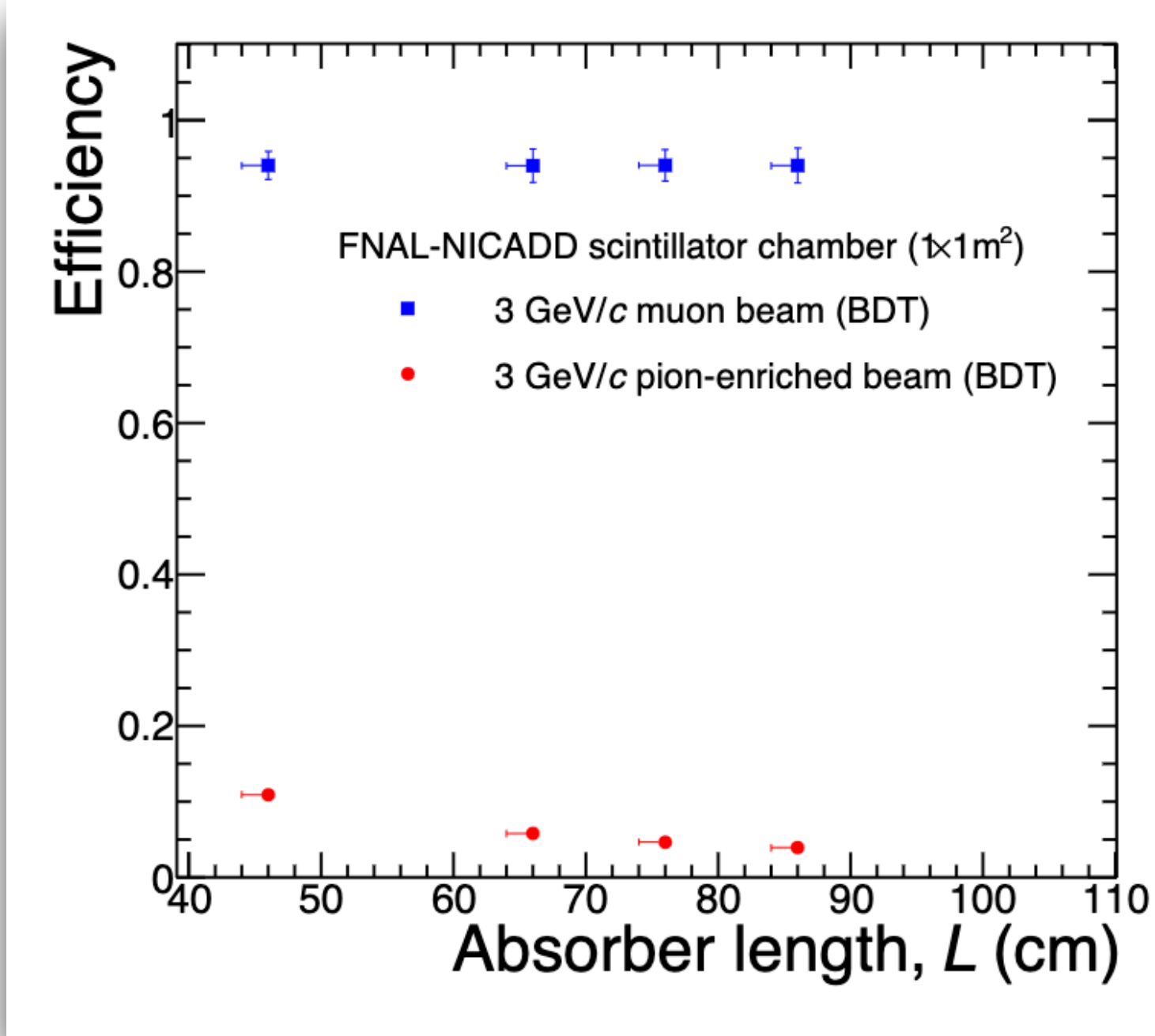

IOPscience Journals Books Publishing Support Login

Journal of Instrumentation

PAPER • OPEN ACCESS

Design and performance of a large-area scintillator-based chamber for the MID subsystem of ALICE 3

Ruben Alfaro Molina, Juan Carlos Cabanillas Noris, Edmundo García Solís, Laura Helena González Trueba, Varlen Grabski, Gerardo Herrera Corral, Jesús Eduardo Muñoz Méndez, Ildelfonso León Monzón, Antonio Ortiz, Antonio Paz, Ian Pérez García, Ricardo Rodríguez Pineda, Solangel Rojas Torres, Guillermo Tejeda Muñoz, Paola Vargas Torres, Victor Vázquez Campos and Yael Antonio Vázquez Beltran [Hide full author list](#)

Published 13 May 2026 • © 2026 The Author(s)

[Journal of Instrumentation, Volume 21, May 2026](#)

Citation Ruben Alfaro Molina et al 2026 *JINST* 21 P05017

DOI 10.1088/1748-0221/21/05/P05017

Activities in 2026



Data taking 2026

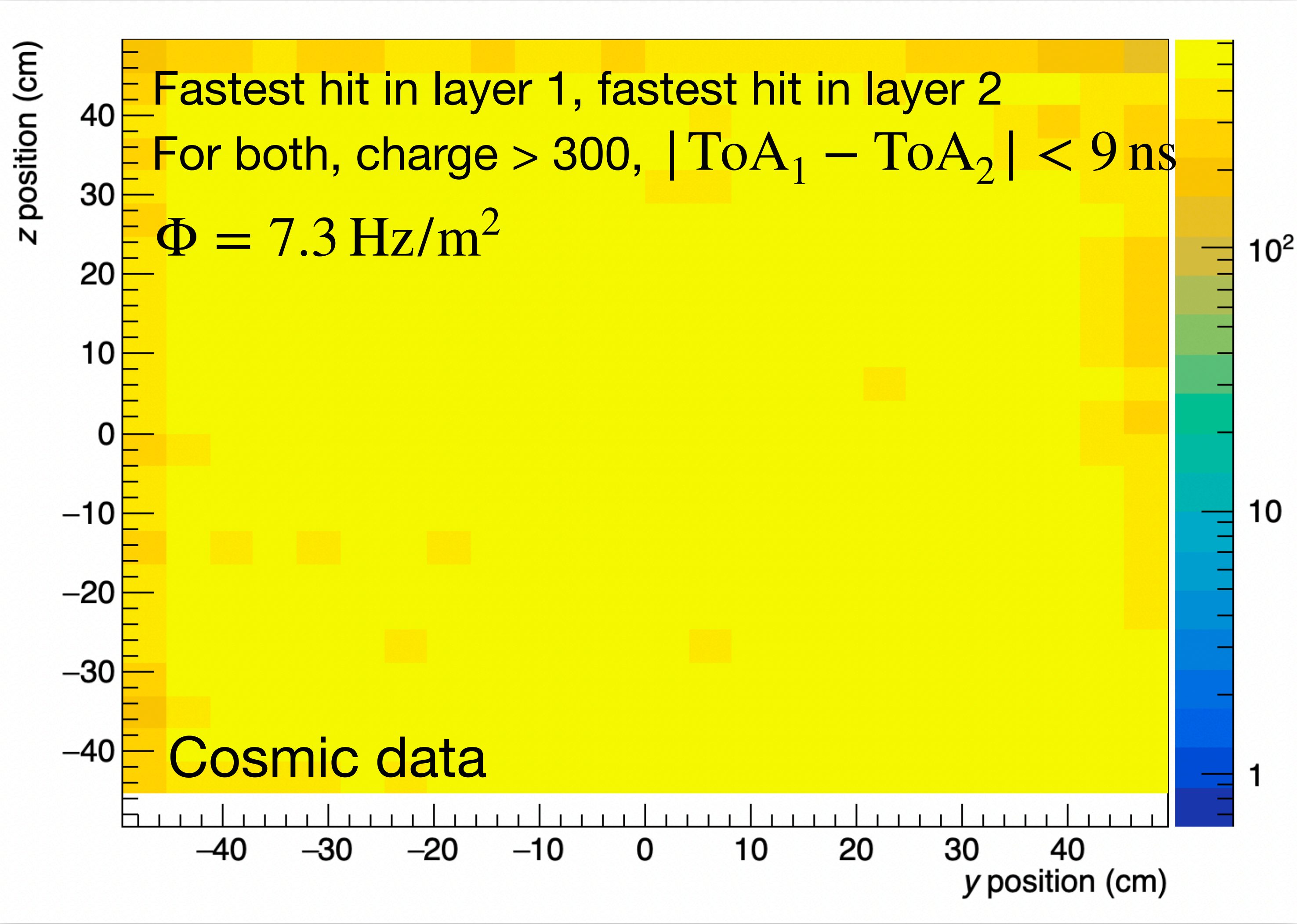

Full simulations in progress...

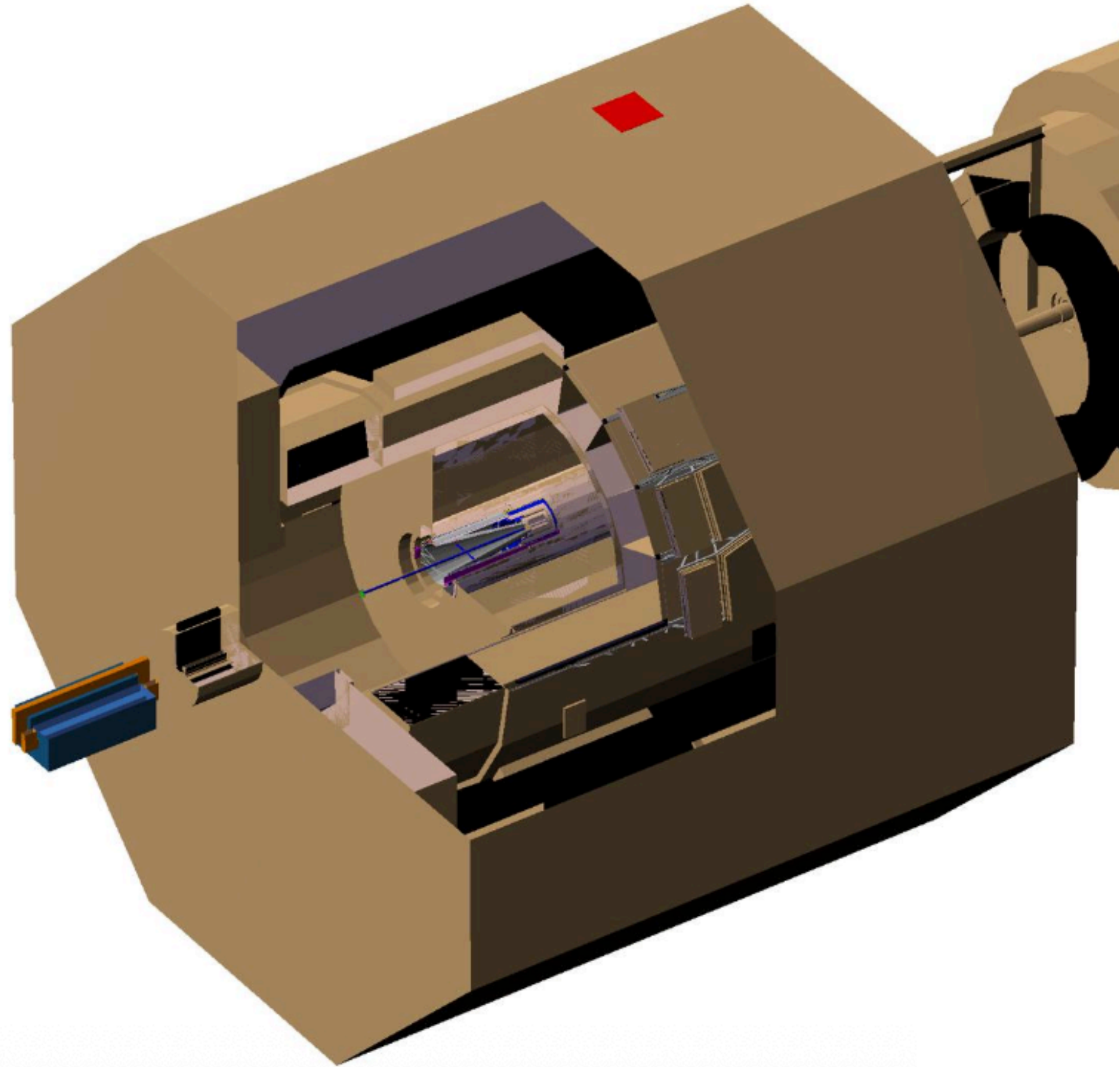

More about MID:

Jesús Eduardo Muñoz [17/06 17:50 'Sala B' Session]

Data taking, pp stable beam

FT0 rate (kHz)	Measured Fluence (Hz/m ²)	Min fluence baed on model (Hz/m ²)	Max fluence based on model (Hz/m ²)
540	96.5	34	170
756	148.6	47	235
524	75.7	33	165

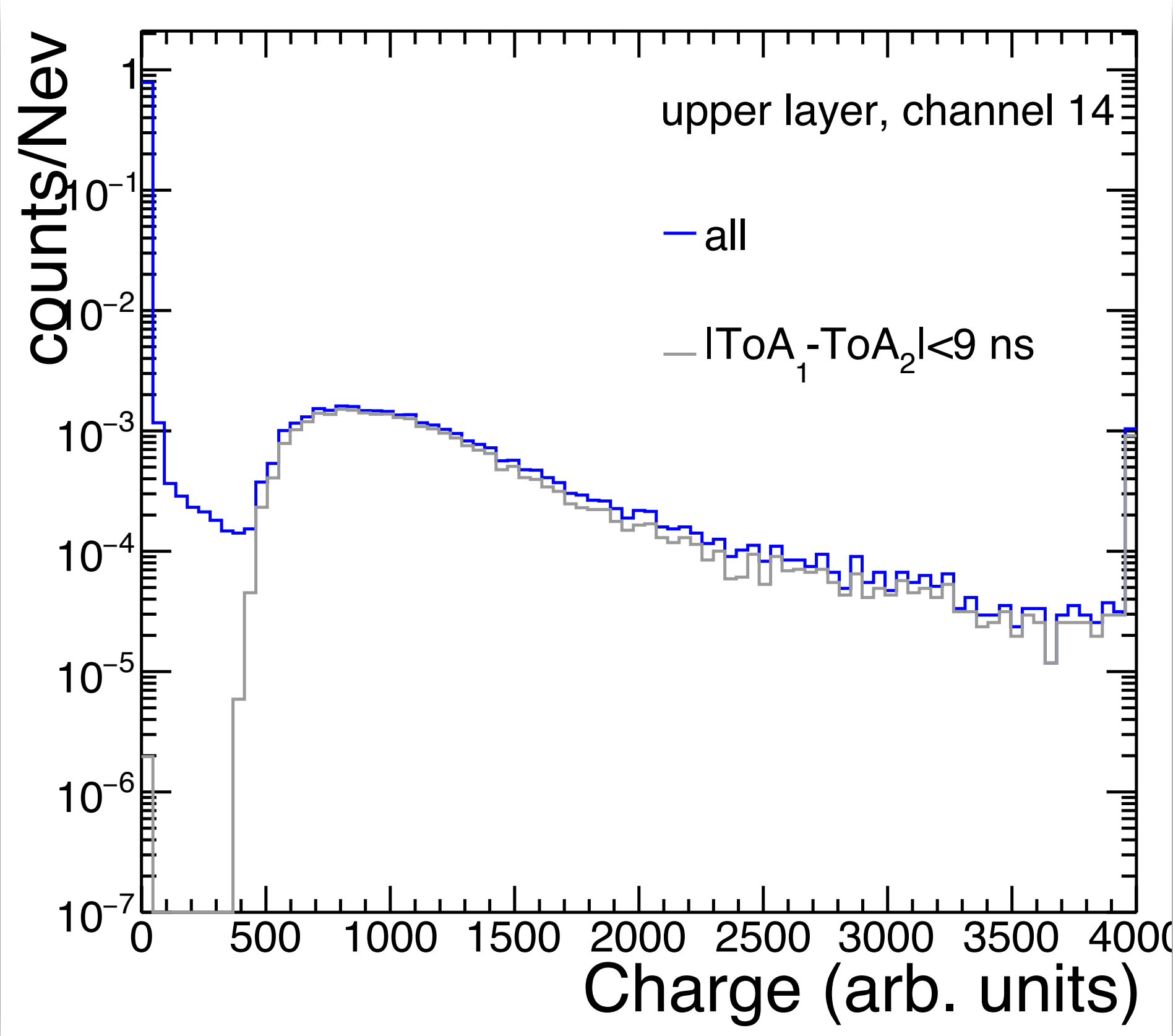

Fastest hit in layer 1, fastest hit in layer 2
 For both, charge > 300, $|ToA_1 - ToA_2| < 9\text{ ns}$
 The atmospheric muon contribution was subtracted

Summary

Run 3 is done

ALICE 2 successful operation: new analysis with LHC Run 3 data

Further developments pursued simultaneously

TDR: ITS3, FoCal in LS3

ALICE 3: the ultimate high-density QCD experiment

MID Mexican proposal is going well



Backup

Time evolution and chiral symmetry

Understand time evolution and mechanisms of chiral symmetry restoration:

- high-precision measurements of dileptons, also multi-differentially
- further reduced material; excellent heavy-flavour rejection

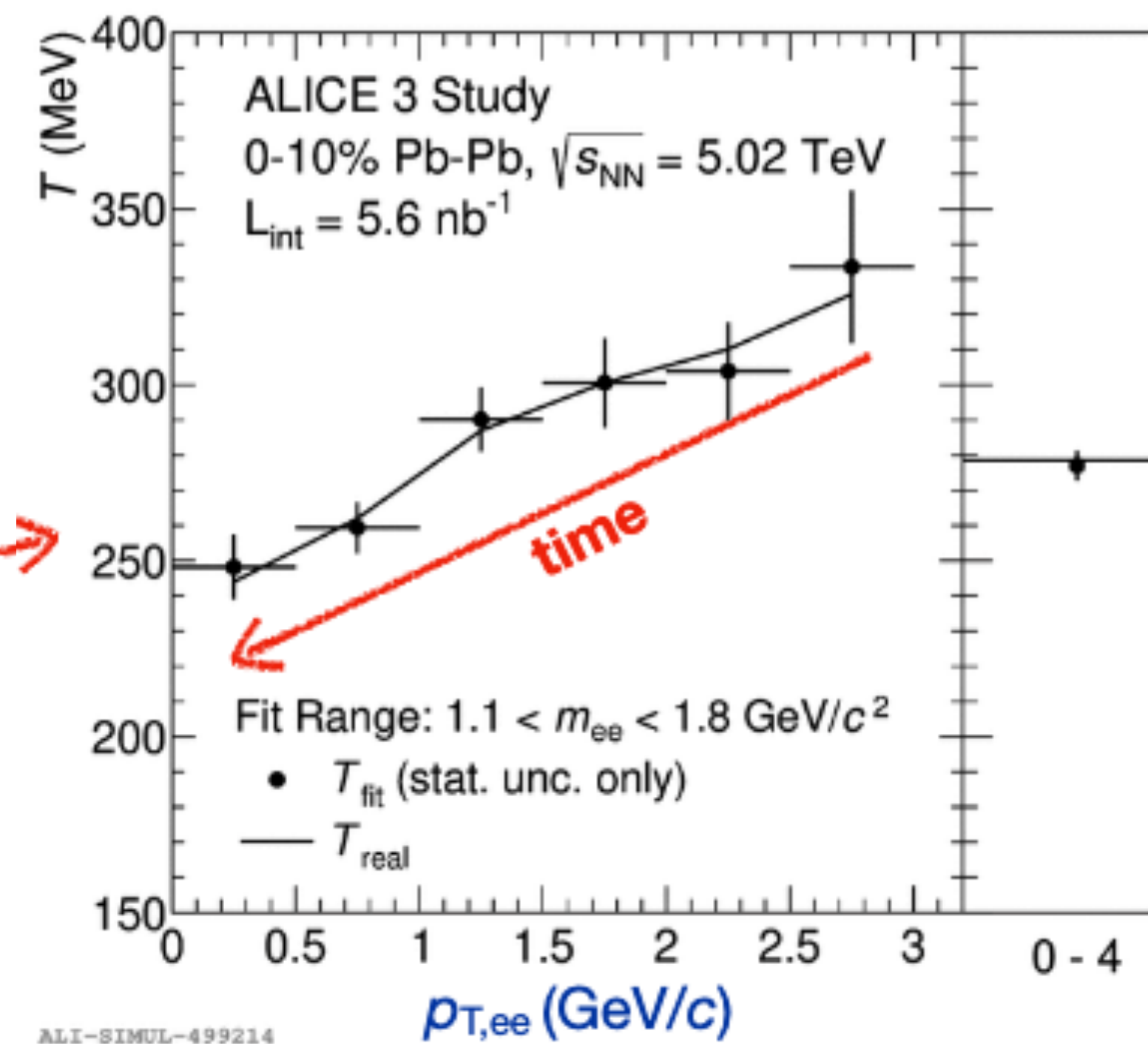
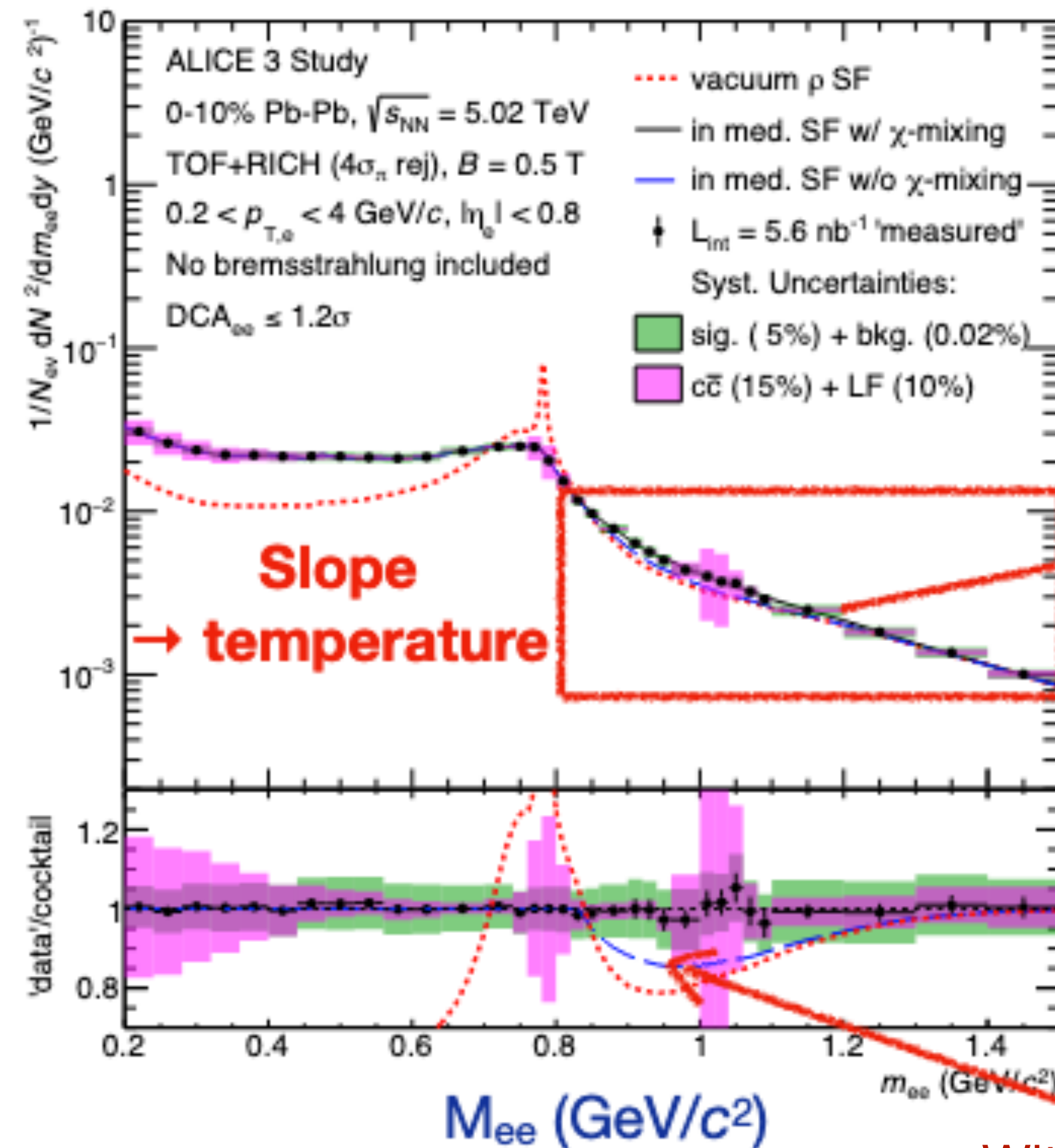
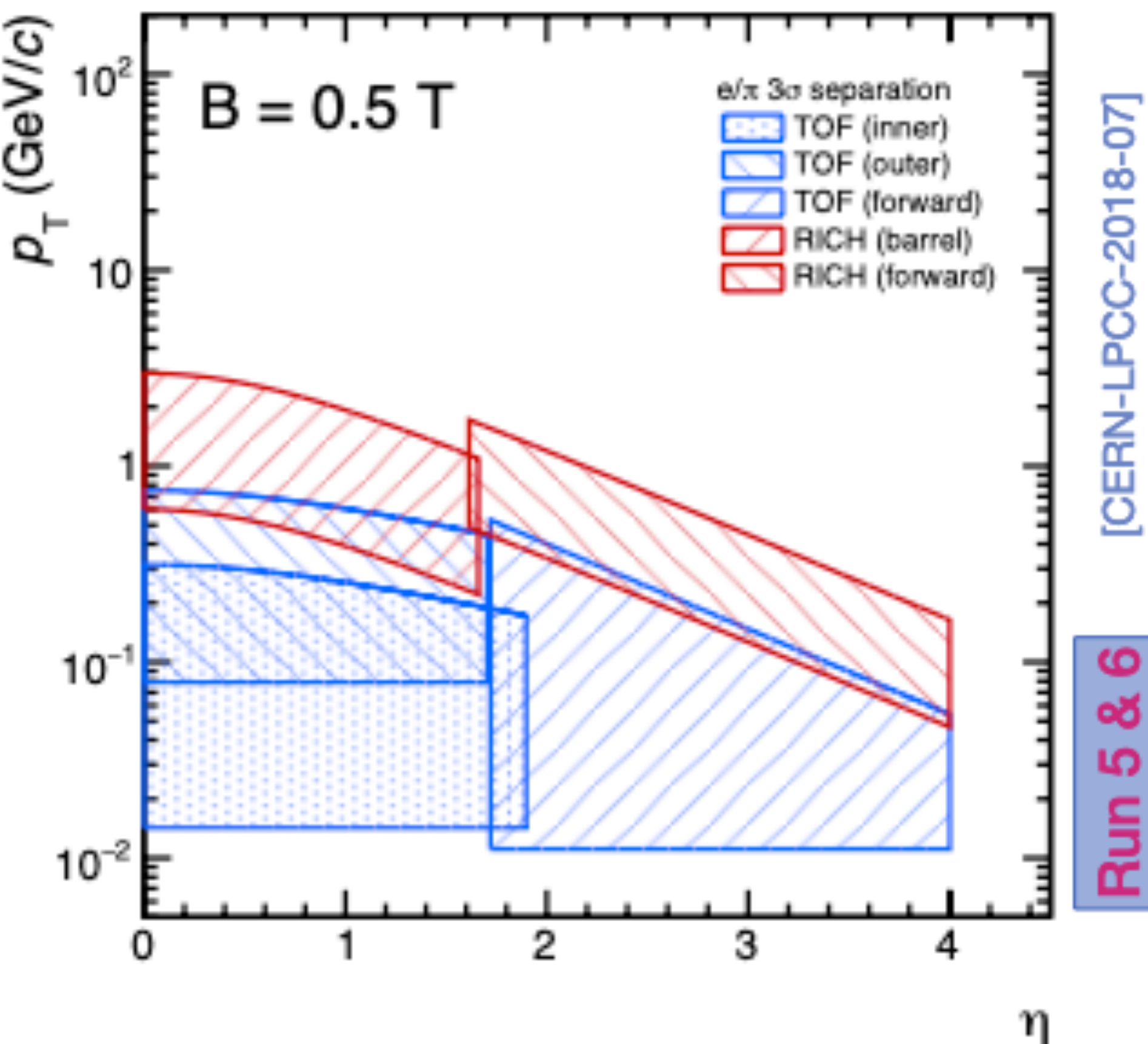

Without ρ -a1 mixing \rightarrow dip in thermal spectrum

* SF: Spectral Function

Exotic hadrons

$$X(3872) \rightarrow J/\psi + \pi^+ \pi^-$$

X(3872)

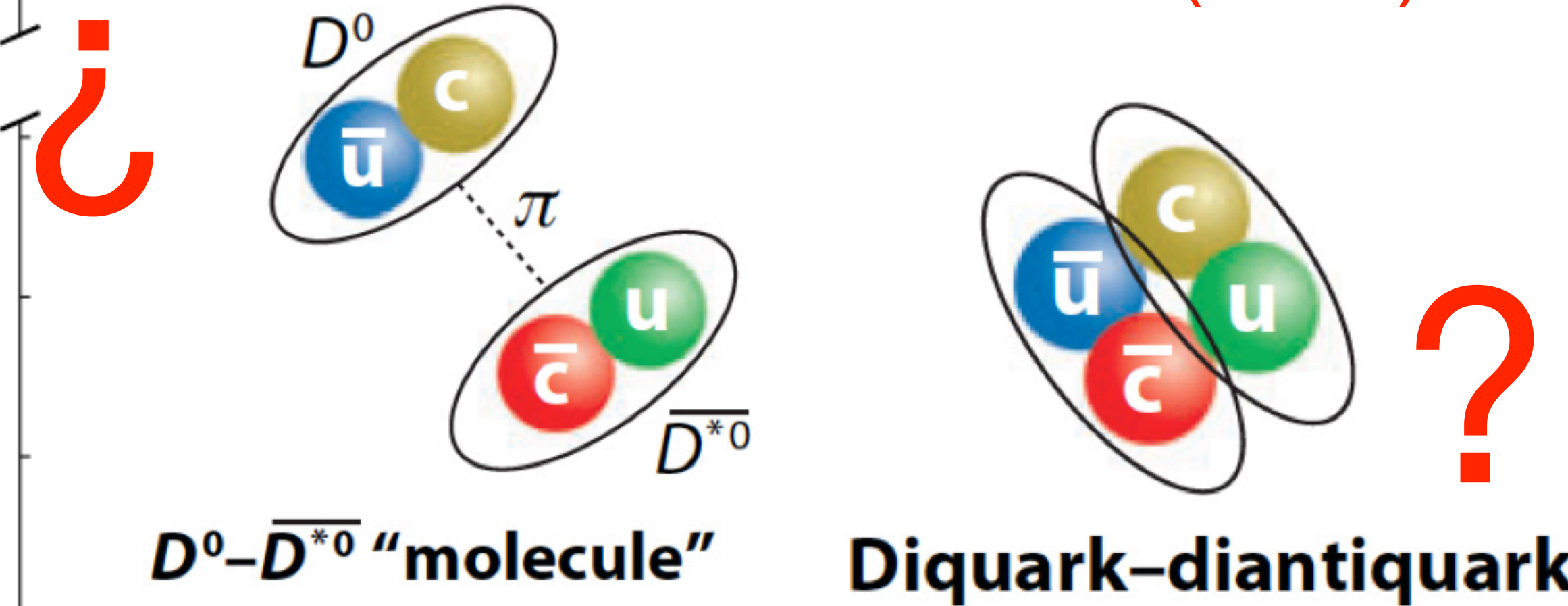
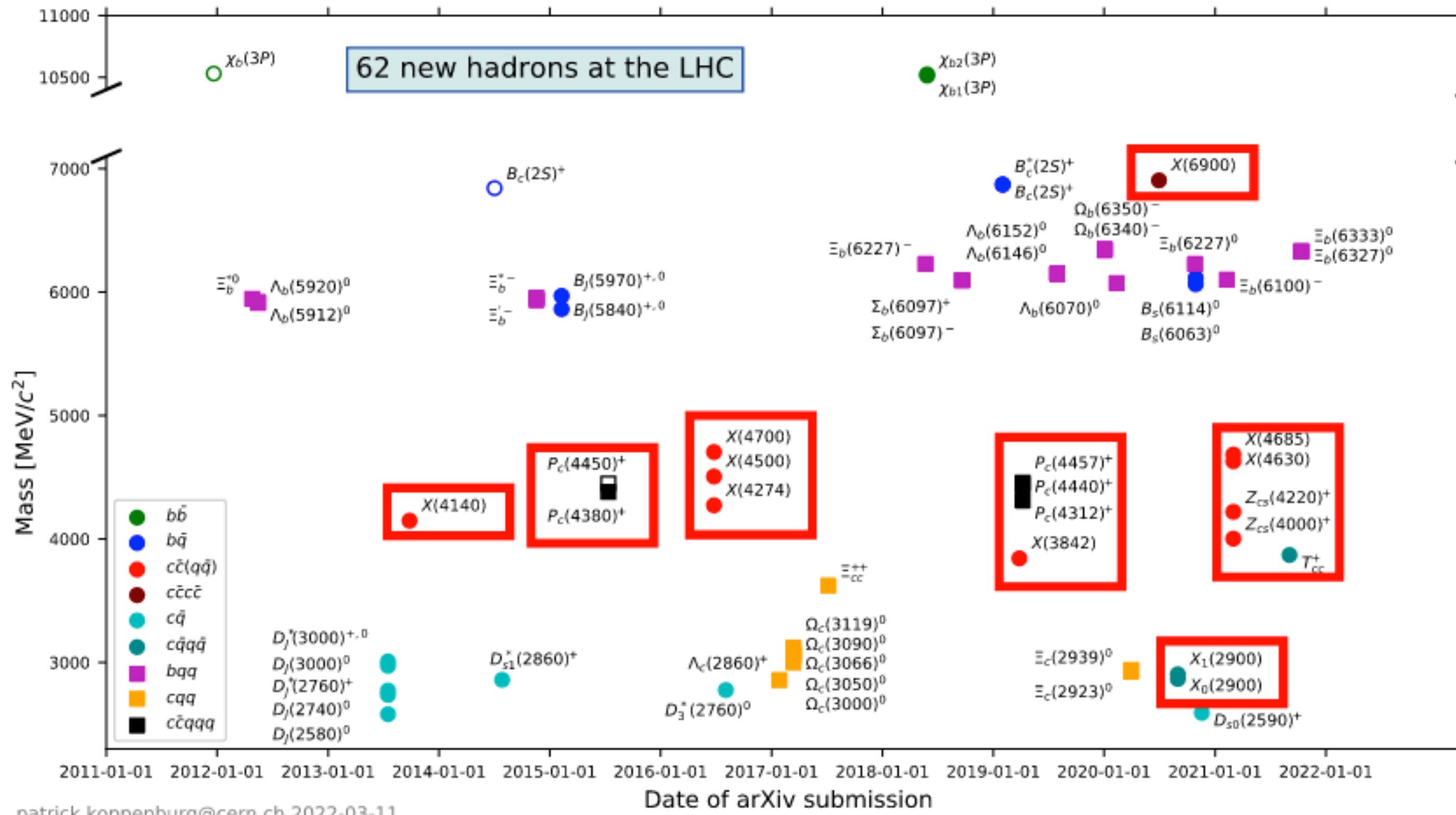

ALICE 3 muonID: muons down to low p_T (~ 1.5 GeV/c at $\eta = 0$) \rightarrow unique p_T reach to study the formation and dissociation of e.g. X(3872) in HIC at thermal momentum scales.
 CMS: $p_T > 10$ GeV/c.

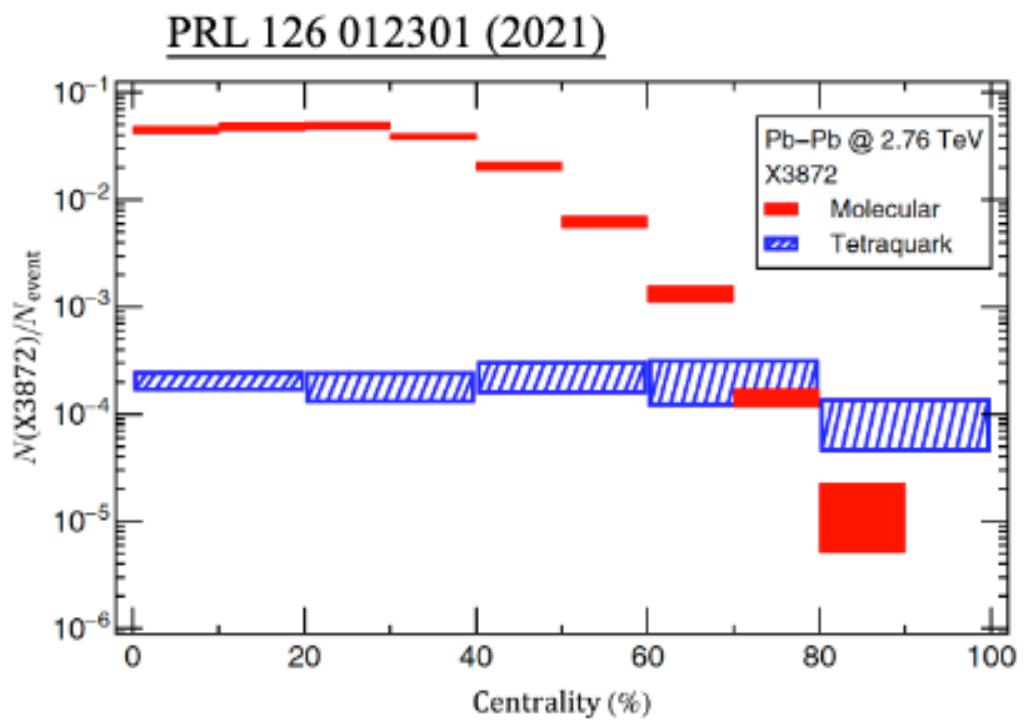
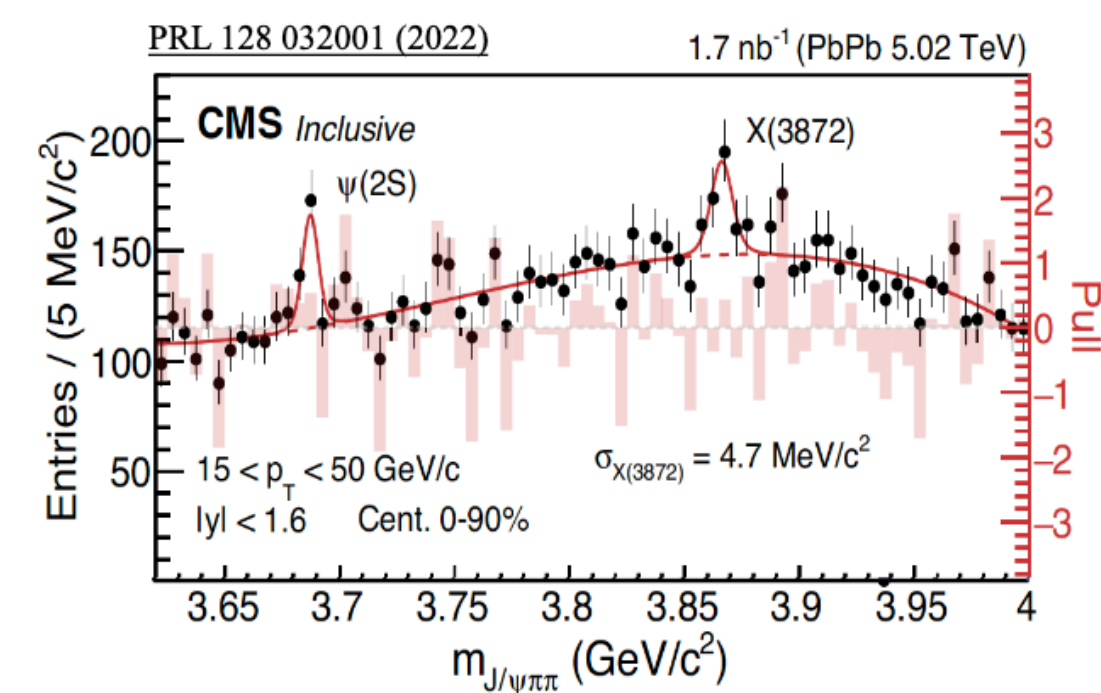

Multicharm state

Expected enhancement of multi-charm states provides high sensitivity to equilibration

- Systematic measurement of hadron yields
- Luminosity, acceptance, vertexing, PID, strangeness tracking

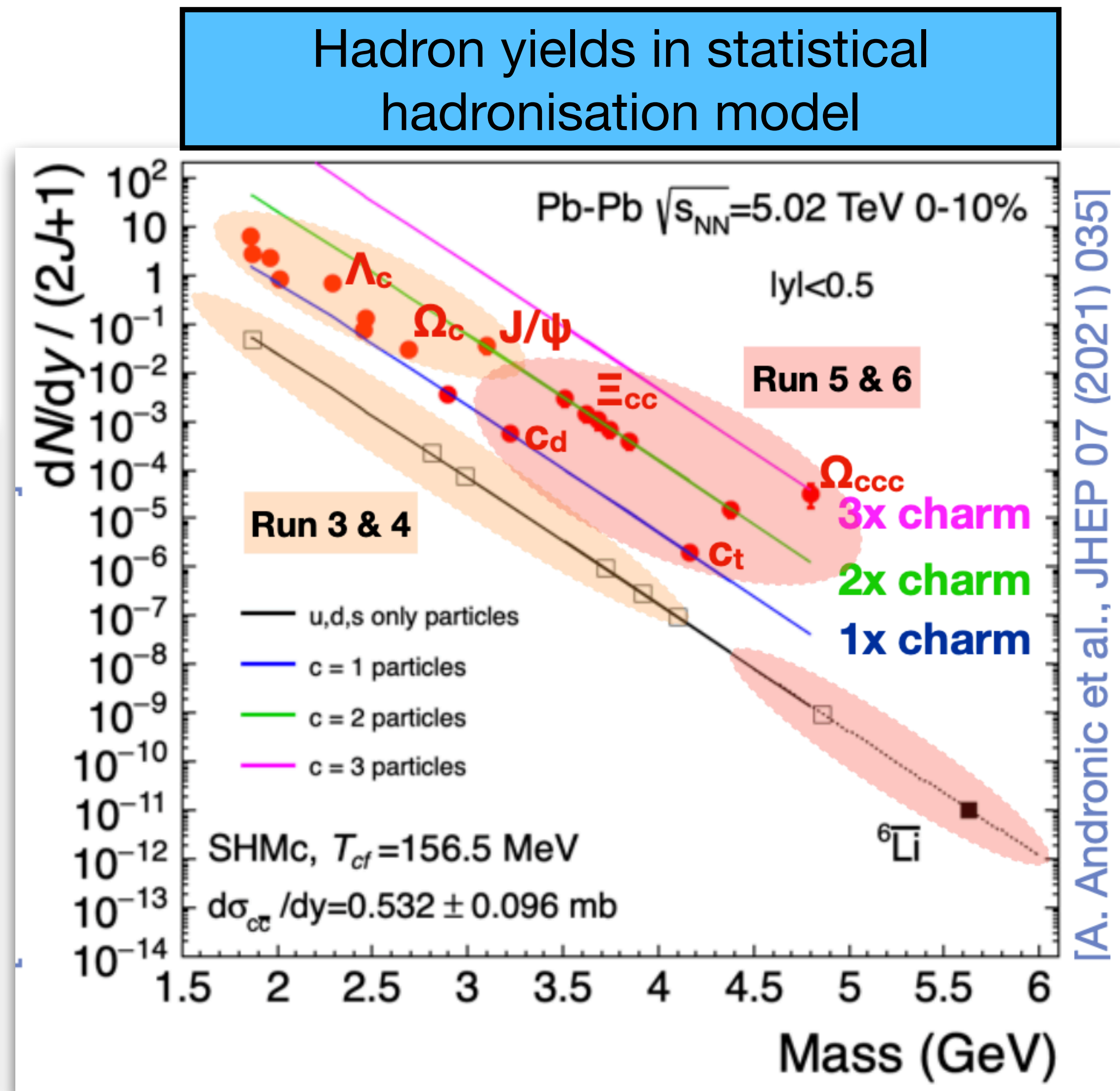
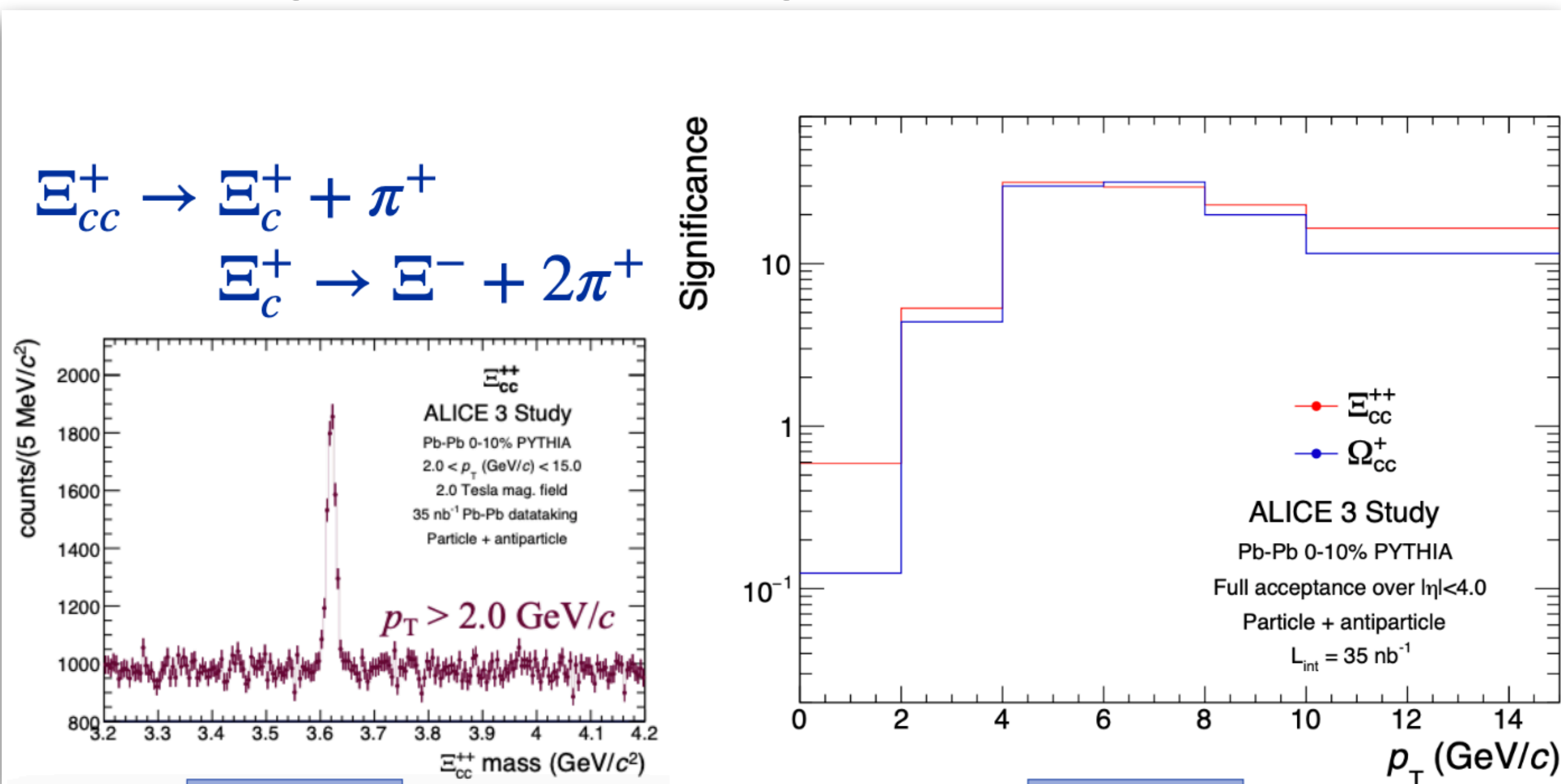

Expected rate with beam

Toy model discussed in ALICE-PUBLIC-2018-012

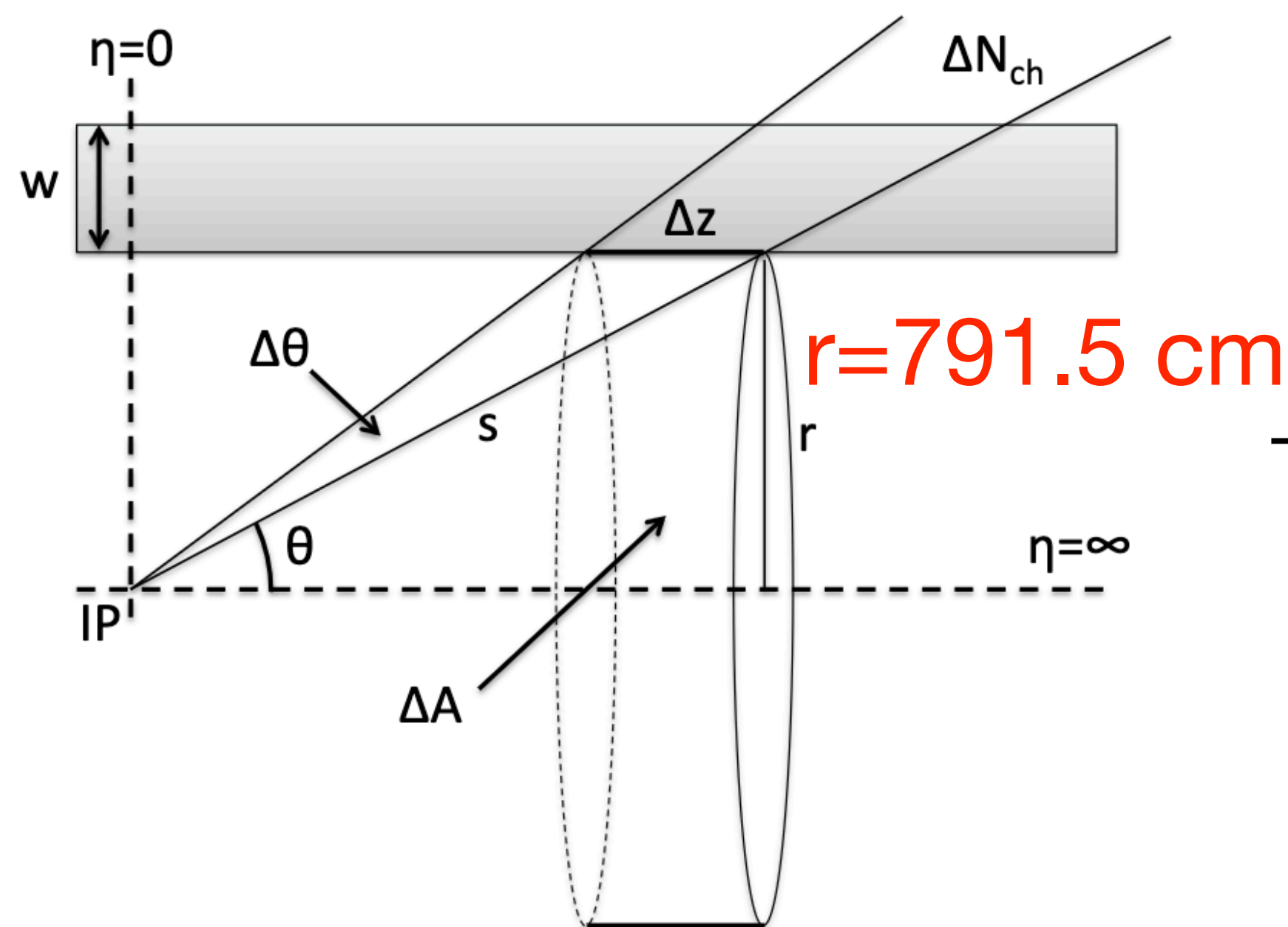

$$\Phi_{\text{ch}}(\text{cm}^{-2}) = \frac{\langle dN_{\text{ch}}/d\eta \rangle}{(2\pi r^2)}$$

Total number of pp collisions (N_{pp}) recorded within Δt_{MID} :

$$N_{\text{pp}} = R_{\text{TF0}} \Delta t_{\text{MID}}$$

Charged particle fluence in MID chamber

$$\Phi_{\text{ch}}(\text{Hz}/\text{cm}^2) = R_{\text{FT0}} \frac{\langle dN_{\text{ch}}/d\eta \rangle}{(2\pi r^2)} \exp(-96/\lambda_{\text{iron}}), \lambda_{\text{iron}} \approx 17 \text{ cm}$$

Model vs full simulation (ALICE 2)

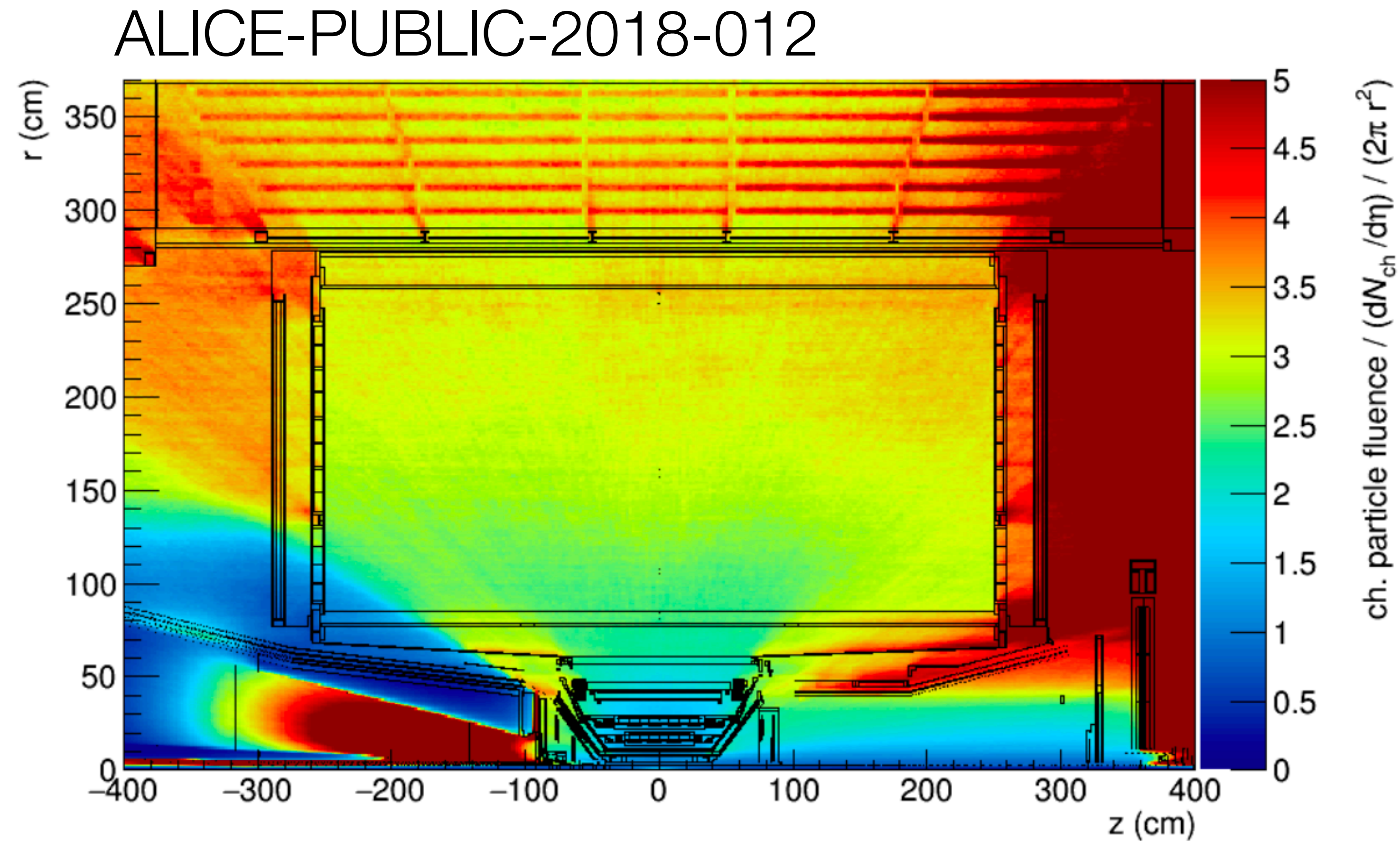

We might expect up to a factor 5 higher charged particle fluence relative to calculation based on the model

Fig. 13: Map of the charged-particle fluence divided by $(dN_{ch}/d\eta) / 2\pi r^2$. The schematic of the ALICE geometry in $r - z$ coordinates is superimposed.

Detector requirements

Component	Observables		Detectors
Vertexing	(Multi-) charm baryons, dielectrons	Best possible DCA resolution, $\sigma_{\text{DCA}} \approx 1 \mu\text{m}$ at $p_{\text{T}} = 200 \text{ MeV}/c$, $\eta = 0$	Retractable Si-pixel tracker: $\sigma_{\text{pos}} \approx 2.5 \mu\text{m}$, $R_{\text{in}} \approx 5 \text{ mm}$, $X/X_0 \approx 0.1 \%$ for the first layer
Tracking	(Multi-) charm baryons, dielectrons, photons ...	$\sigma_{p_{\text{T}}}/p_{\text{T}} \approx 1 - 2 \%$	Silicon pixel tracker: $\sigma_{\text{pos}} \approx 10 \mu\text{m}$, $R_{\text{out}} \approx 80 \text{ cm}$, $X/X_0 \approx 1 \%$ per layer
Hadron ID	(Multi-) charm baryons	$\pi/\text{K}/p$ separation up to a few GeV/c	Time of flight: $\sigma_{\text{tof}} \approx 20 \text{ ps}$ RICH: $n \approx 1.006 - 1.030$, $\sigma_{\theta} \approx 1.5 \text{ rad}$
Electron ID	Dielectrons, quarkonia, $\chi_{\text{cl}}(3872)$	Pion rejection by 1000x top to 2-3 GeV/c	Time of flight: $\sigma_{\text{tof}} \approx 20 \text{ ps}$ RICH: $n \approx 1.006 - 1.030$, $\sigma_{\theta} \approx 1.5 \text{ rad}$
Muon ID	Quarkonia, $\chi_{\text{cl}}(3872)$	Reconstruction of J/ψ at rest, i.e. muons from $p_{\text{T}} \approx 1.5 \text{ GeV}/c$ at $\eta = 0$	Steel absorber: $L \approx 70 \text{ cm}$ muon chambers (scintillators)