

Outline

- **NICA-MPD**
 - Experiment
 - Physics motivation
- **MiniBeBe**
 - Design & purpose
 - Electronics & Mechanics
- **Phenomenology (MexNICA)**
 - Criticality
 - Vorticity
 - EM probes





Joint Institute for Nuclear Research

SCIENCE BRINGING NATIONS TOGETHER

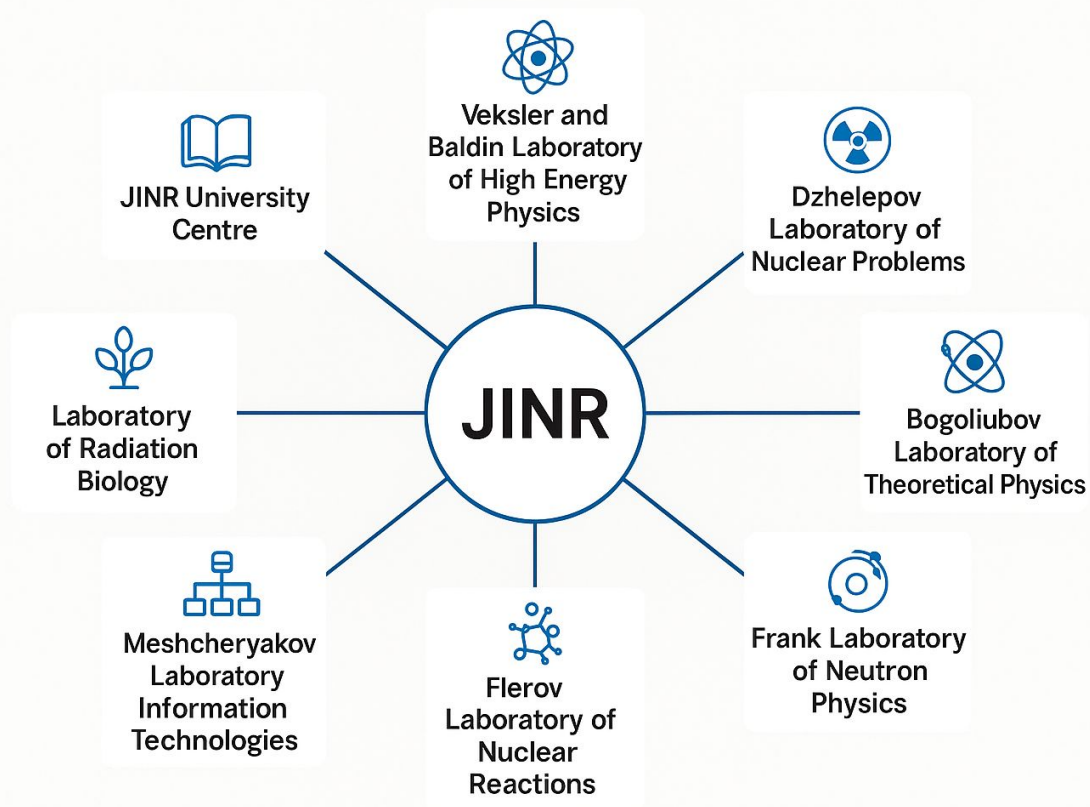

NICA

Nuclotron-based Ion Collider fAcility



Joint Institute for Nuclear
Research

SCIENCE BRINGING NATIONS TOGETHER

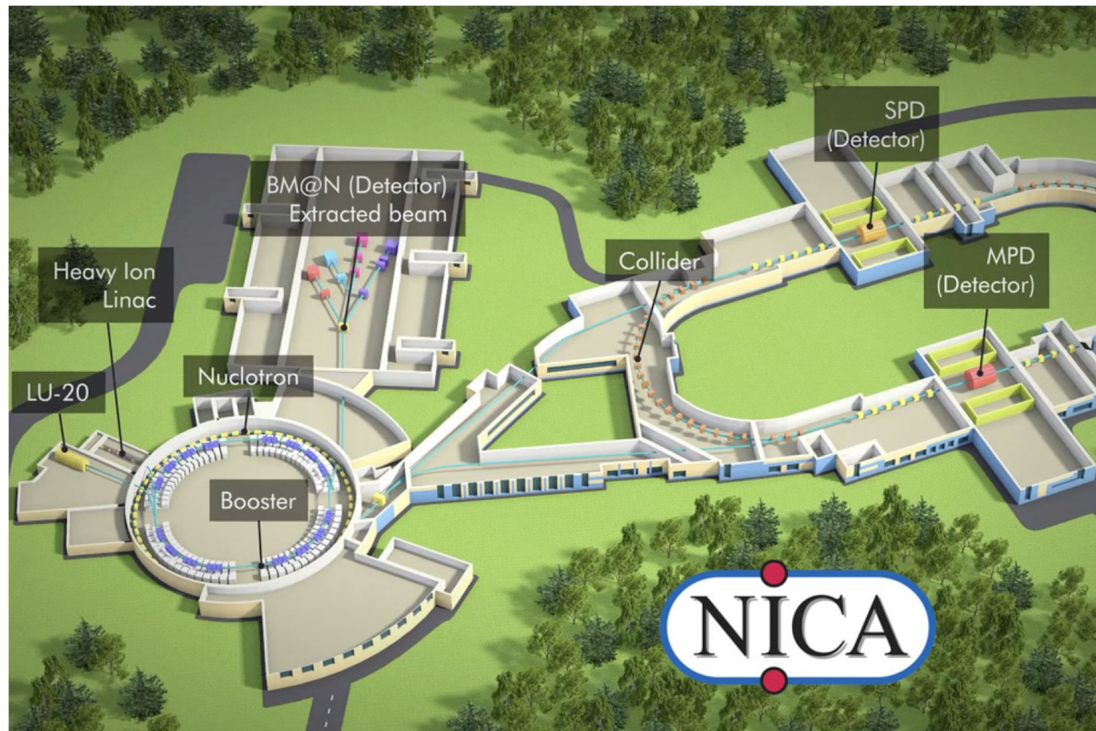

NICA

1

BM@N

Baryonic Matter at Nuclotron

2

SPD

Spin Physics Detector

3

MPD

Multi-Purpose Detector



MPD at NICA

The **M**ulti-**P**urpose **D**etector apparatus has been designed as a 4π spectrometer capable of detecting charged hadrons, electrons and photons in heavy-ion collisions at high luminosity in the energy range of the NICA collider.

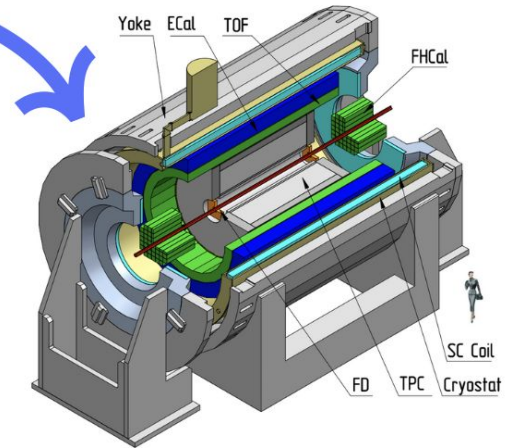
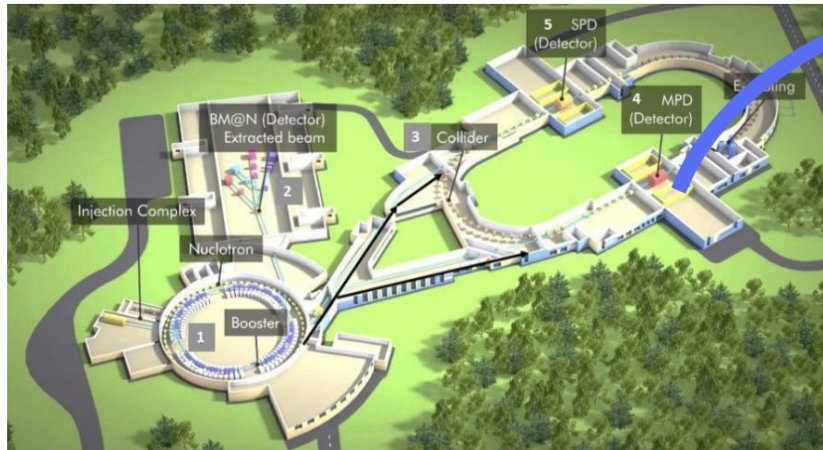

Multi-Purpose Detector

Stage-I → start of commissioning in 2025

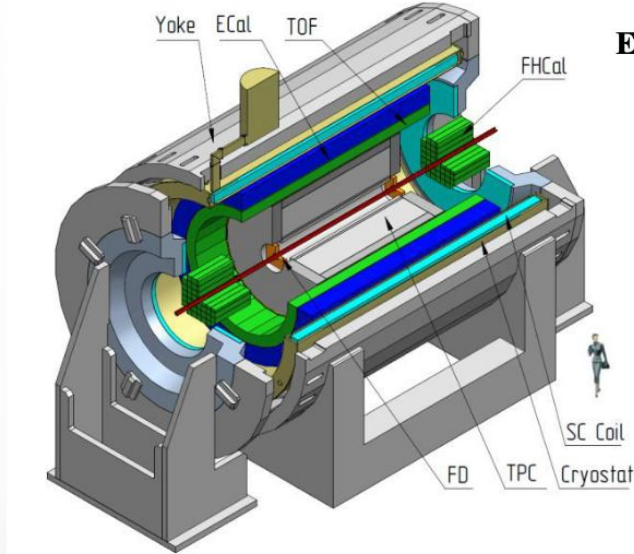

Eur.Phys.J.A 58 (2022) 7, 140

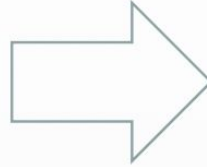

Stage-II → 2030+

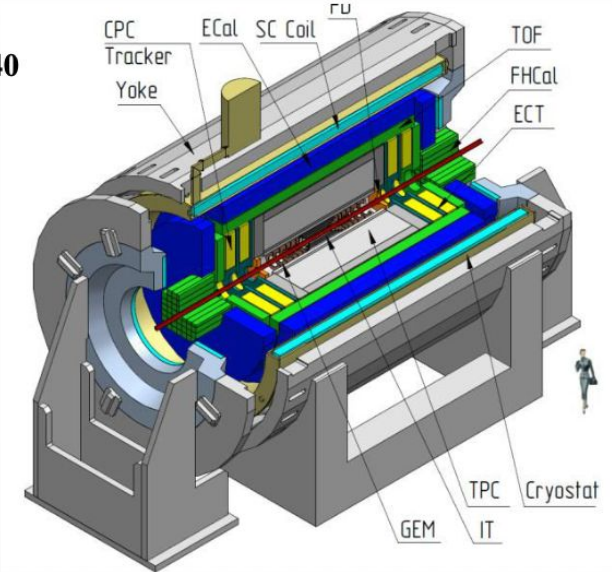

TPC: $|\Delta\phi| < 2\pi$, $|\eta| \leq 1.6$; **TOF, EMC:** $|\Delta\phi| < 2\pi$, $|\eta| \leq 1.4$
FFD: $|\Delta\phi| < 2\pi$, $2.9 < |\eta| < 3.3$; **FHCAL:** $|\Delta\phi| < 2\pi$, $2 < |\eta| < 5$

+ **ITS** : $|\Delta\phi| < 2\pi$, $|\eta| \leq 3$
+ **Forward Spectrometers:** $|\Delta\phi| < 2\pi$, $|\eta| \leq 2.2$

Central barrel subsystems

Frame - ready



Carbon fiber support frame delivered and unpacked, sagitta ~ 5 mm at full load, rails for the TPC and TOF are installed

ECAL

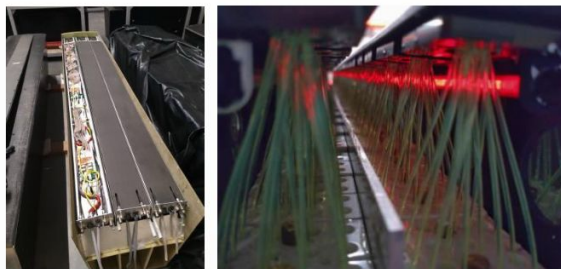

ECAL ~ 38400 towers (2400 modules) produced by Tsinghua University, Shandong University, Fudan University, South China University, Huzhou University and JINR – production in IHEP (Protvino) and Tenzor (Dubna)
45 half-sectors to be ready by August, the rest depends on WLS fiber supply from Tver

TOF - ready



All 28 (100%) TOF modules are assembled, tested, stored and ready for installation.
Spare modules in production

TPC – central tracking detector

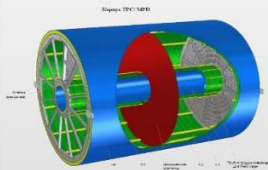

24+ ROC ready;
100+ % FE cards manufactured

Ongoing TPC gas volume assembly and HV/leakage tests
TPC + ECAL cooling systems under commissioning

Forward subsystems

FHCAL - ready



FHCAL assembled on the platform,
(modules are equipped with FEE)

Test installation of FHCAL → autumn 2024
Final installation → Autumn 2025

FFD - ready

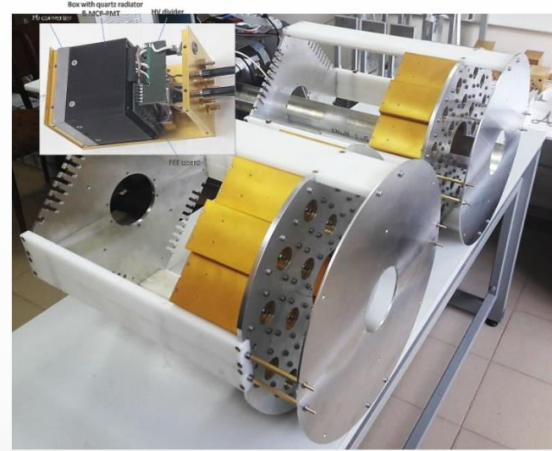

Cherenkov modules of FFDE and FFDW, mechanics for installation in container with beam pipe are available,
Long term tests with cosmic rays & laser ongoing

Beam and luminosity monitoring

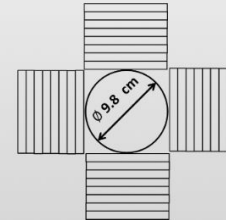
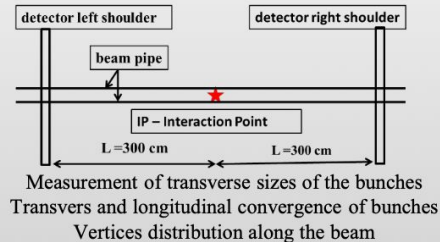
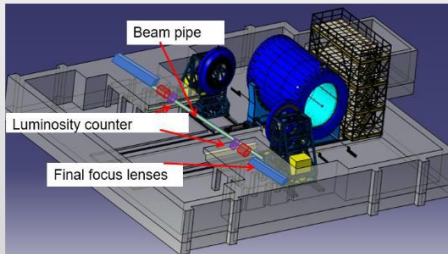

Assembly of the main components of the detector for the Run on the collider beam – end of 2025

- ❖ High-luminosity scans in **energy** and **system size** to measure a wide variety of signals
- ❖ Scans to be carried out using the **same apparatus** with all the advantages of collider experiments
- ❖ MPD-CLD and MPD-FXT operation modes approved from start-up:

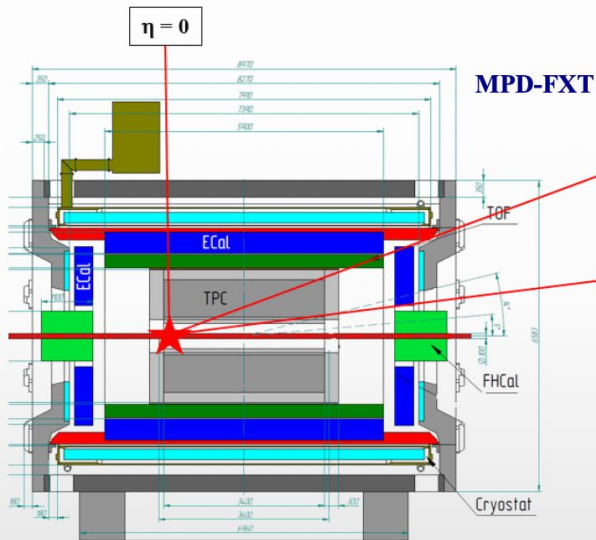

$\eta \approx 1.6$

$\eta \approx 2.9$

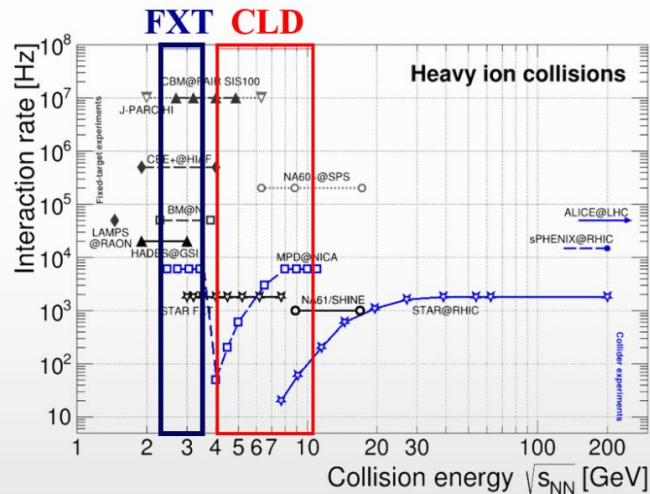

- ✓ Collider mode: two heavy-ion beams, $\sqrt{s_{NN}} = 4-11$ GeV
- ✓ Fixed-target mode: one beam + thin wire as a target ($\sim 50-100$ μm) :
 - extends energy range to $\sqrt{s_{NN}} = 2.4-3.5$ GeV (overlap with HADES, BM@N, CBM)
 - high event rate at lower collision energies

NICA is a quark-baryonic bridge to neutron stars

- Heavy-ion collisions are used to:
 - Study QCD under extreme conditions of high temperatures and densities.
 - Explore the QCD phase diagram, search for the QGP and study its properties.

- Why is the quark-gluon plasma of interest?
 - It is the primordial form of QCD matter at high temperatures and/or net baryon densities.
 - It existed during the first microseconds after the Big Bang and possibly in the cores of compact neutron stars and their mergers.
 - Studying it provides key insights into the origin of mass for matter, and how quarks are confined into hadrons.

- Heavy-ion collisions at NICA create extremely dense matter at moderate temperatures:
 - Net baryon density (n) up to 10 times that in normal nuclear matter (n_0)
 - Baryonic chemical potential $\mu_B = (300 - 600)$ MeV, $T_{ch} \sim (120-150)$ MeV

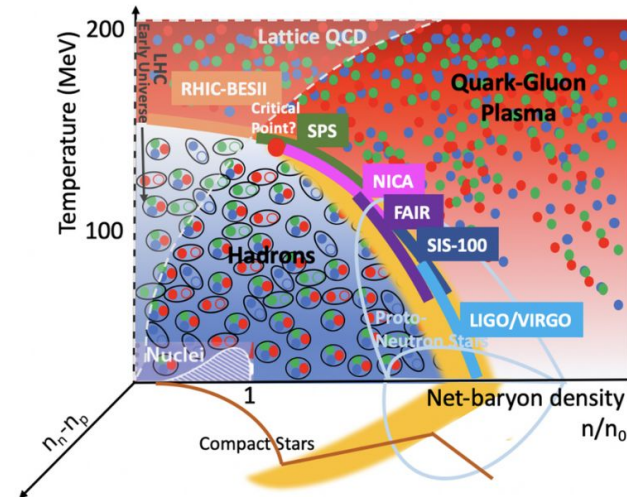
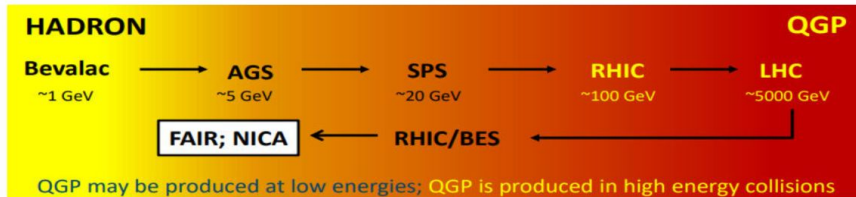

Mexican participation in the MPD-NICA

Multi-Purpose Detector (MPD) Collaboration



MPD International Collaboration was established in 2018 to construct, commission and operate the detector

12 Countries, >500 participants, 38 Institutions and JINR

Organization

Acting Spokesperson: **Victor Riabov**
Deputy Spokespersons: **Zebo Tang, Arkadiy Taranenko**
Institutional Board Chair: **Alejandro Ayala**
Project Manager: **Slava Golovatyuk**

Joint Institute for Nuclear Research:

A.Aikhanyan National Lab of Armenia, Yerevan, **Armenia**;
Institute for Nuclear Problems of Belarusian State University, **Belarus**;
Institute of Power Engineering of the National Academy of Sciences of Belarus, **Belarus**;
University of Plovdiv, **Bulgaria**;
Tsinghua University, Beijing, **China**;
University of Science and Technology of China, Hefei, **China**;
Huzhou University, Huizhou, **China**;
Institute of Nuclear and Applied Physics, CAS, Shanghai, **China**;
Central China Normal University, **China**;
Shandong University, Shandong, **China**;
University of Chinese Academy of Sciences, Beijing, **China**;
University of South China, **China**;
Three Gorges University, **China**;
Institute of Modern Physics of CAS, Lanzhou, **China**;
Egyptian Center for Theoretical Physics, **Egypt**;
Tbilisi State University, Tbilisi, **Georgia**;
Institute of Physics and Technology, Almaty, **Kazakhstan**;
Instituto de Ciencias Nucleares, UNAM, **Mexico**;
Universidad Autónoma de Sinaloa, **Mexico**;
Universidad Autónoma Metropolitana, **Mexico**;
Universidad de Colima, **Mexico**;
Universidad Michoacana de San Nicolás de Hidalgo, **Mexico**;
Institute of Physics and Technology, **Mongolia**;

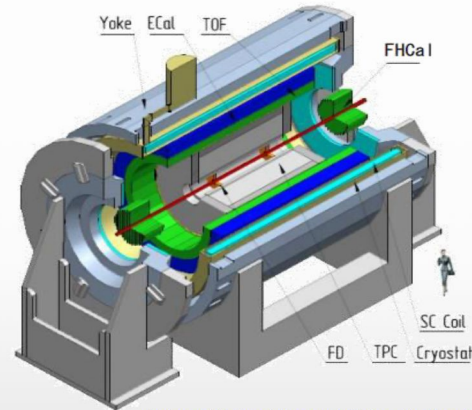

Belgorod National Research University, **Russia**;
High School of Economics University, Moscow, **Russia**;
Institute for Nuclear Research of the RAS, Moscow, **Russia**;
National Research Nuclear University MEPhI, Moscow, **Russia**;
Moscow Institute of Science and Technology, **Russia**;
North Ossetian State University, **Russia**;
National Research Center "Kurchatov Institute", **Russia**;
National Research Tomsk Polytechnic University, **Russia**;
Peter the Great St. Petersburg Polytechnic University Saint Petersburg, **Russia**;
Plekhanov Russian University of Economics, Moscow, **Russia**;
St.Petersburg State University, **Russia**;
Skobel'syn Institute of Nuclear Physics, Moscow, **Russia**;
Petersburg Nuclear Physics Institute, Gatchina, **Russia**;
Vinča Institute of Nuclear Sciences, **Serbia**;
Pavol Jozef Šafárik University, Košice, **Slovakia**



UNIVERSIDAD DE COLIMA



Mini BeBe

Mini Beam Beam Monitoring Detector

MPD trigger complement FFD + Mini BeBe (to be efficient for low multiplicity p+p, p+A and A+A events as well as to have a fast response).

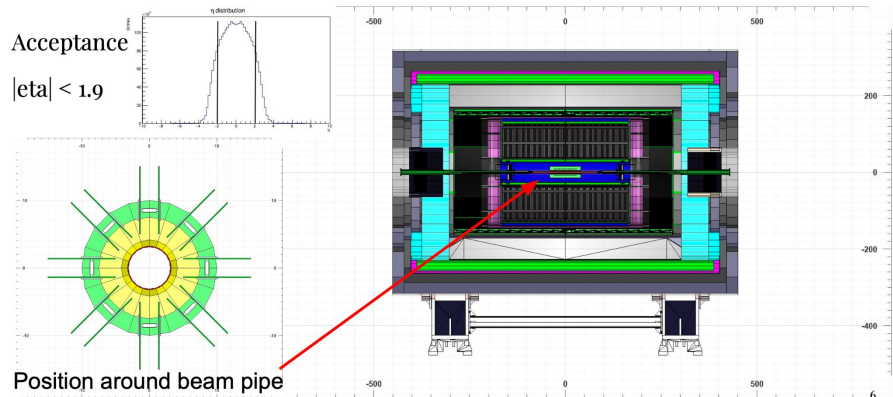
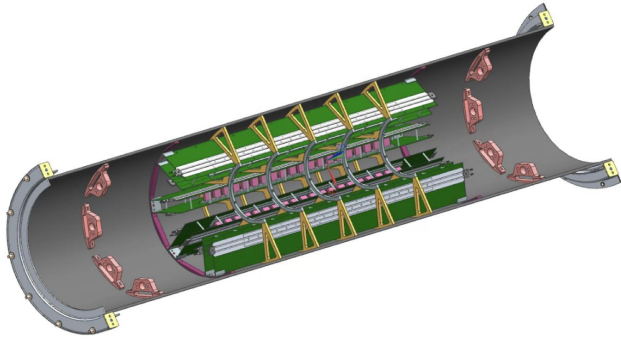

Mini BeBe Mechanics

The design includes the installation of 8 electronic modules, 4 on each half of the casing.

H Modules

The detector consists of eight H-shaped rails (8 cm wide and 80 cm long) forming a cuboid structure containing 20 EJ232 plastic scintillators (20×20×5 mm) flanked by Hamamatsu S13360-3050PE SiPMs on each side, accompanied by PT100 temperature sensors. The assembly is modular, with 20 cells per rail.

Power Supplies

Low-noise, high-voltage switched power supply with 320 output channels.

Connection Cables between H Modules and Front-End Electronics Boards (Data and Power)

SAMTEC cables, ranging from two to three meters in length, are used to interconnect the H modules with the Front-End electronics (Data and Power).

Mini BeBe

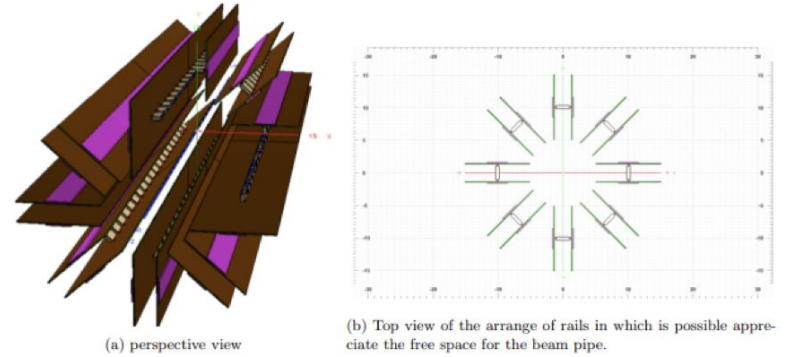

Figure 2: Schematic view of MiniBeBe formed by 8 H-shaped rails.

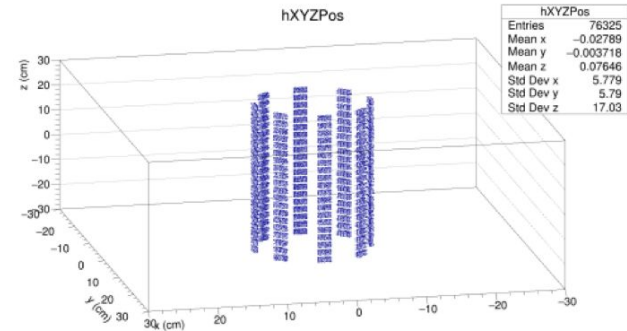

Figure 3: MbbPoints left by particles when interact with sensitive volume of detector

Mini BeBe

Front-End Electronics Boards

Electronics 2–3 m from H-modules, for signal conditioning and transmission to FERS modules. Their function is to receive, discriminate, condition, and process the signals generated by the detector, so they can be transmitted to the CAEN FERS modules.

CAEN FERS 5200 Modules

A real-time data acquisition platform specifically designed to handle a large number of readout channels, enabling tasks such as:

- Signal filtering
- Feature extraction (amplitude, time of arrival, among others)
- Noise reduction
- Event discrimination and classification
- Precise synchronization between modules.

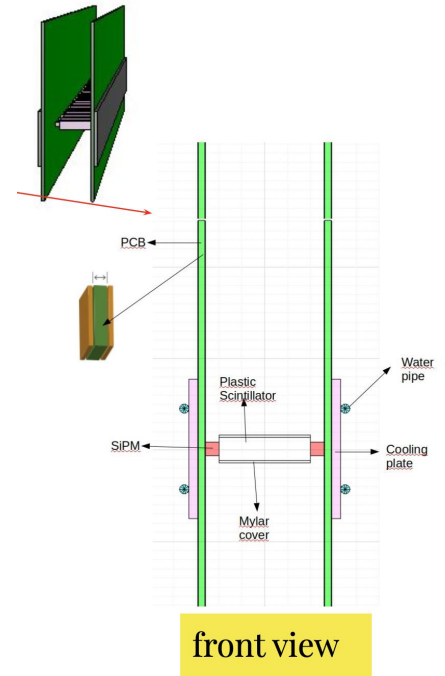
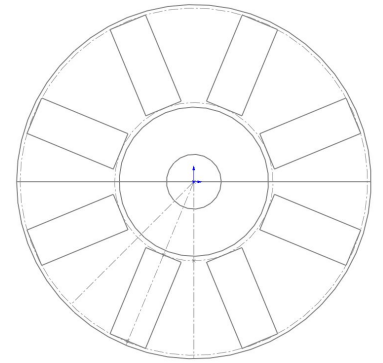

Mini BeBe

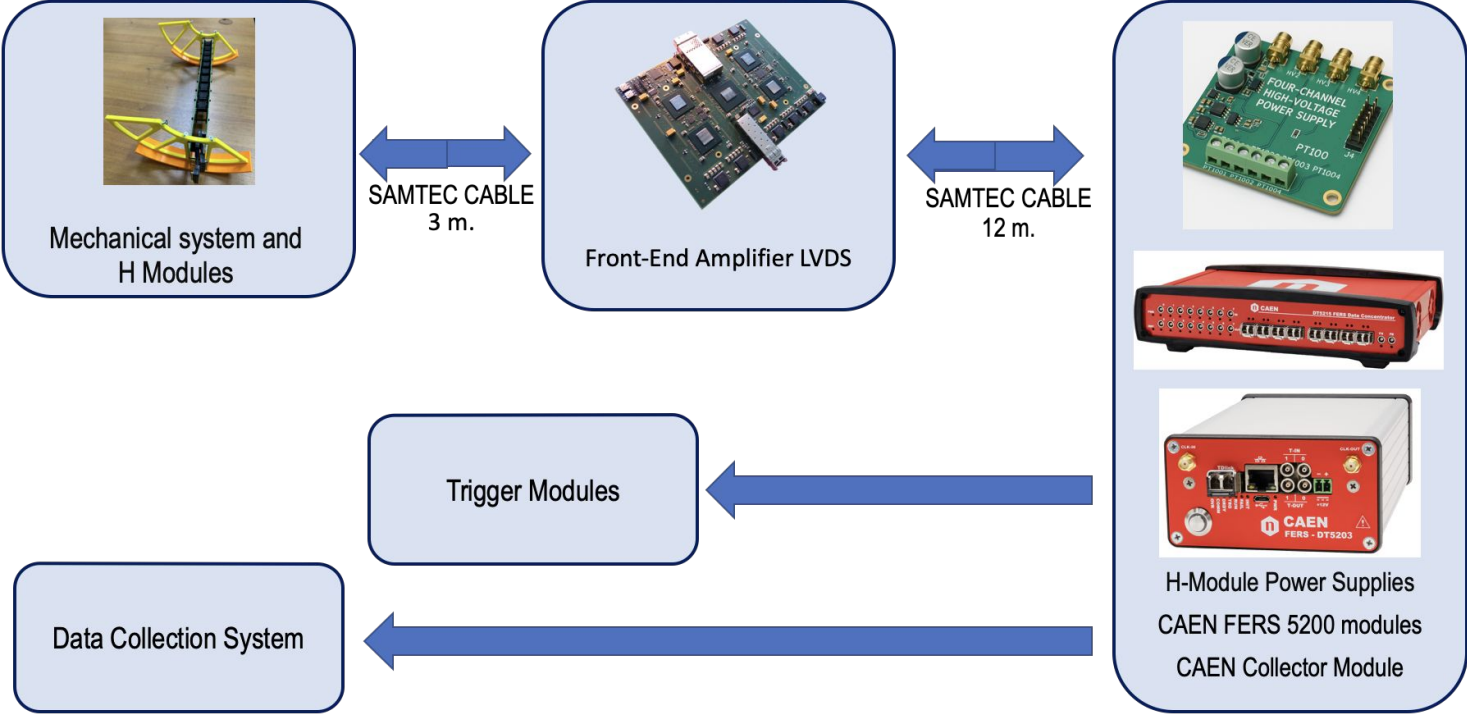

Phenomenology - MexNICA

- ☐ Signals of criticality
 - ☐ Pion correlations
 - ☐ Critical Exponents
 - ☐ Lévy index of stability (non-monotonic near the CEP).
 - ☐ Baryon number fluctuations
 - ☐ Statistical moments
 - ☐ Kurtosis (large and diverging near the CEP).
 - ☐ Fixing parameters.

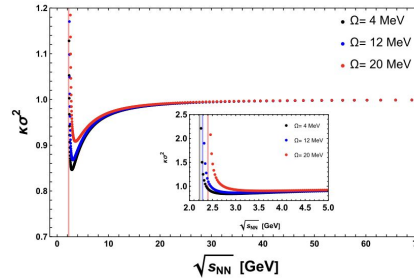

L. A. H. and R. Zamora, Phys.Rev.D 111 (2025) 9, 096019.

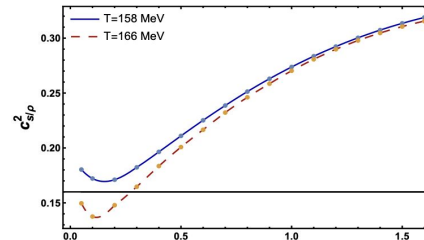

S. Hernandez-Ortiz, F. Martinez and A. Raya, Eur.Phys.J.A 60 (2024) 7, 154

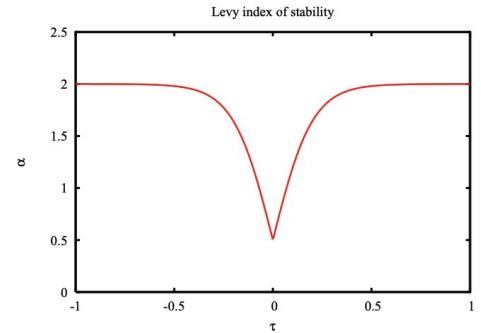

T. Csörgo, S. Hegyi, T. Novák and W. A. Zajc, AIP Conf. Proc. 828 (2006) 525.

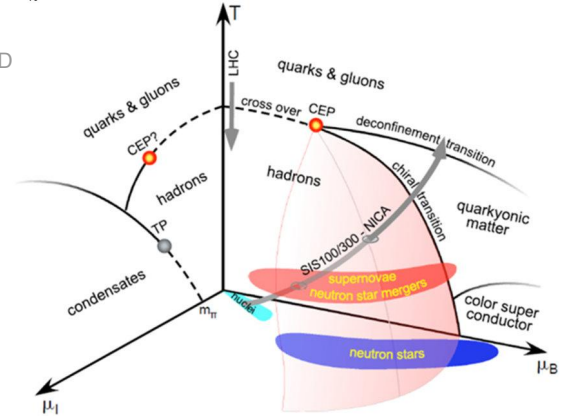

NUPECC Long Range Plan 2017

Metropolitan Grid
UNAM-IPN-UAM

New EoS with CEP
UNAM-UAM-MIT-UIUC-UH

Phenomenology - MexNICA

Vorticity

- ☐ Hyperon polarization Λ & anti- Λ
 - ☐ Core-corona model
 - ☐ Chiral symmetry restoration
 - ☐ Inverse vortical effect.

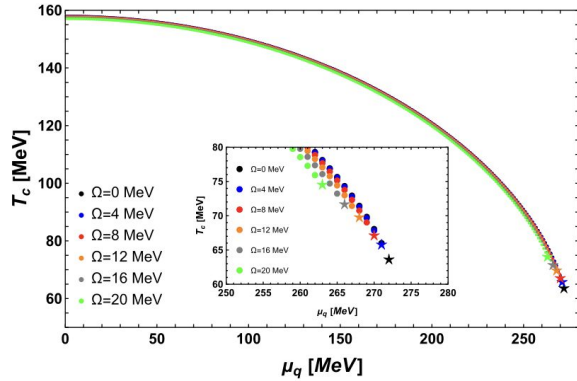

L. A. H. and R. Zamora, Phys.Rev.D 111 (2025) 9, 096019.

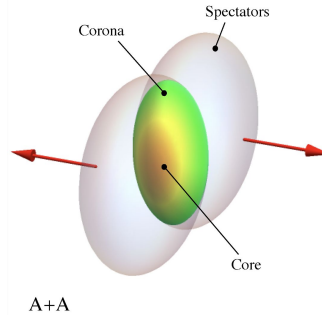

Intrinsic polarization

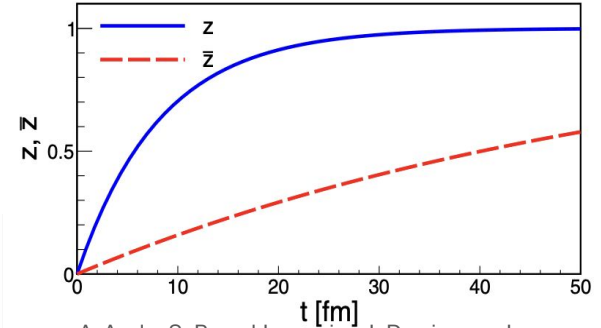

A. Ayala, S. Bernal-Langarica, I. Dominguez, I. Maldonado, J. J. Medina-Serra, Phys.Rev.D 109 (2024) 7, 074018.

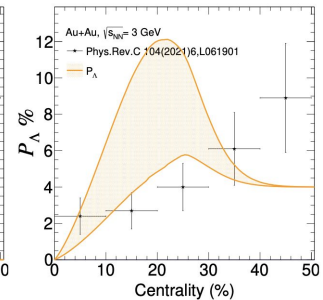
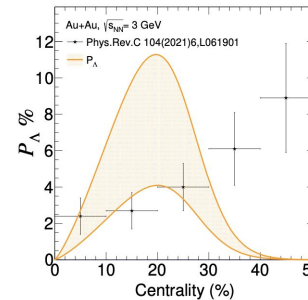
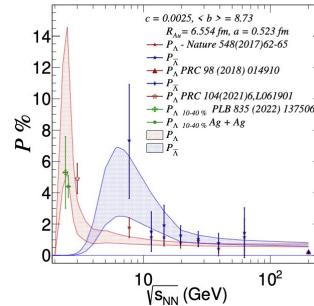

A. Ayala, I. Dominguez, I. Maldonado, M. E. Tejada-Yeomans, Particles 6 (2023) 1, 405-415

Phenomenology - MexNICA

- Electromagnetic probes.
 - Photon puzzle
 - Gluon fusion with vorticity
 - Dilepton yield and azimuthal distribution
 - Process through electric fields.

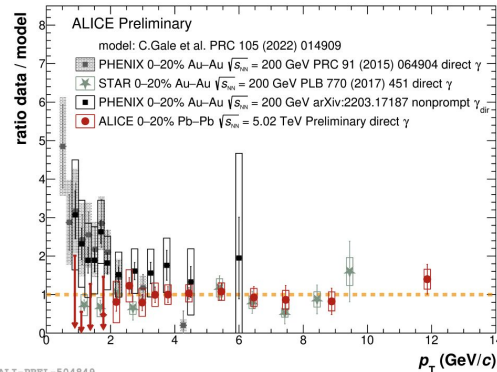
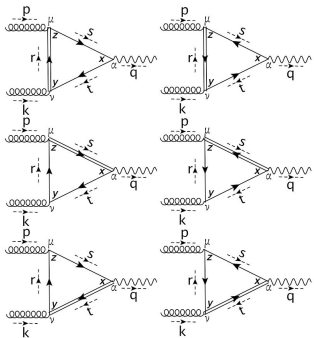
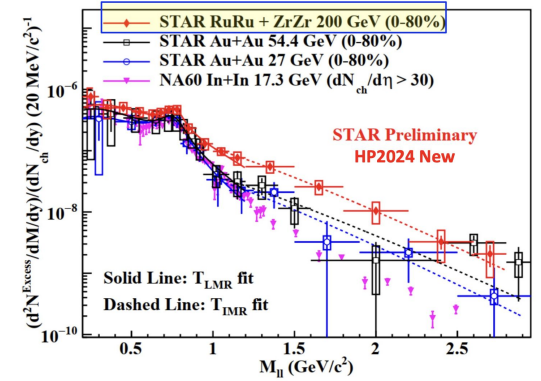
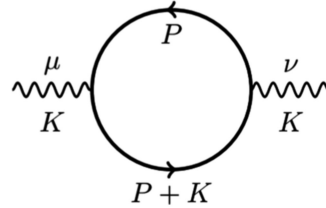

ALI-PREL-504849

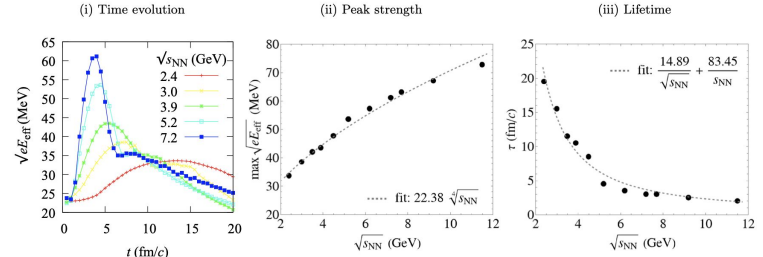

H. Taya, T. Nishimura and A. Ohnishi, Phys.Rev.C 110 (2024) 1, 014901

Important moment for NICA experiment

- ❑ This was a 19-year journey.
 - ❑ 2006 Alexei Sissakian (former JINR director) presented the project
- ❑ 2009 the Committee of Plenipotentiaries approved the concept.
- ❑ 2016 the first pile was driven.
- ❑ March 2025: Run No. 1 started at NICA
 - ❑ Xenon ions
- ❑ 2026: First collisions.



Important moment for Mexico-JINR collaboration

- ❑ *Vinculación con Organismos Internacionales de Investigación 2025*
 - ❑ “Basic science and advanced technology using radiation sources and beams in collaboration with the Joint Institute for Nuclear Research”
 - ❑ ~15 MDP, UNAM-UMSNH-UAM-UCoI-UAS.
- ❑ Intention to sign new cooperation agreements. JINR delegation to visit SECIHTI in December 2025.
- ❑ Beyond high-energy physics, we are exploring research stay opportunities for graduate students and postdoctoral researchers across all JINR research areas.

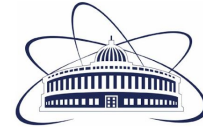

Joint Institute for Nuclear
Research

SCIENCE BRINGING NATIONS TOGETHER

**Ciencia y
Tecnología**

Secretaría de Ciencia, Humanidades,
Tecnología e Innovación



Thank you for your attention!

