

XIX MEXICAN WORKSHOP ON PARTICLES AND FIELDS

MMWPF2025

20 - 24 OCTUBRE 2025 • LEÓN, GUANAJUATO, MX.

ALICE status and overview

Antonio Ortiz, for the ALICE Collaboration
(Instituto de Ciencias Nucleares, UNAM)

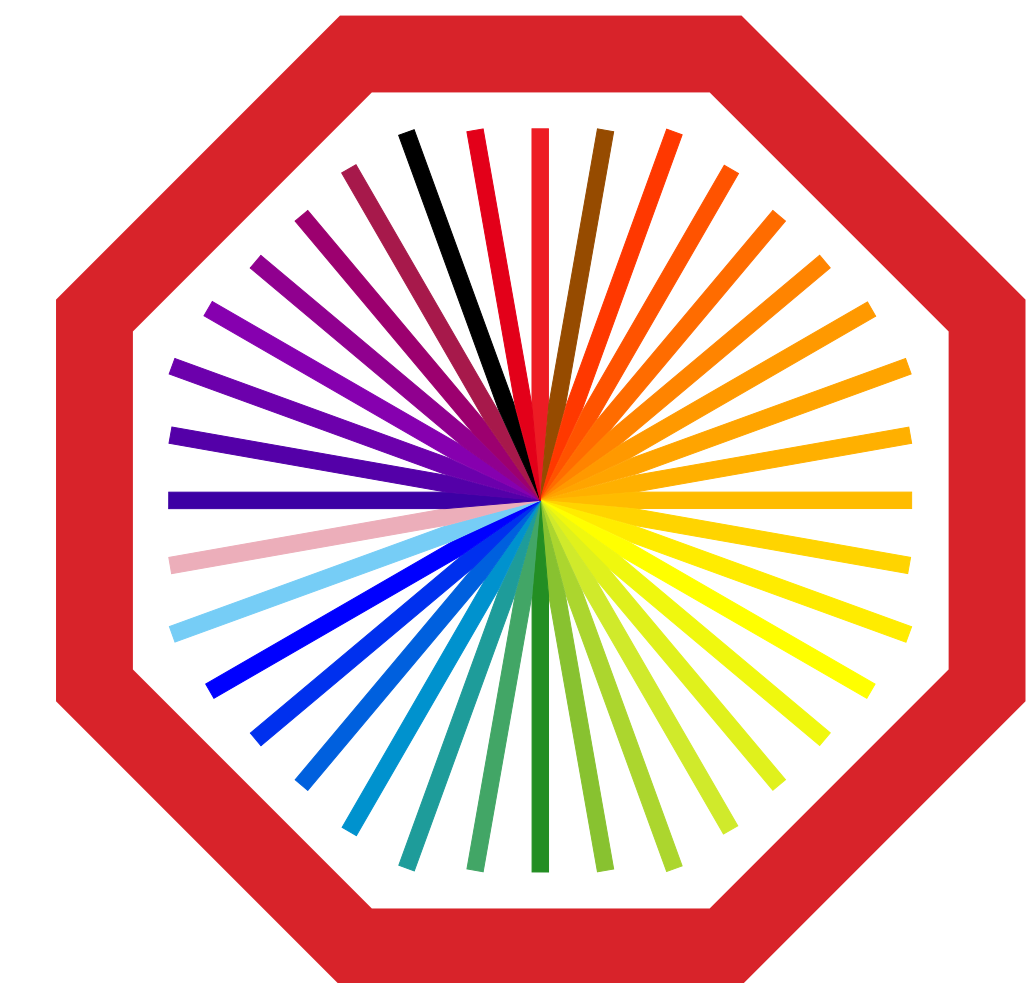

Introduction

ALICE upgrade for the LHC Run 3

Heavy-ion results (selected list)

Small systems including light ions

Upgrades: LS3 and LS4 (ALICE 3)

The MID subsystem

Summary

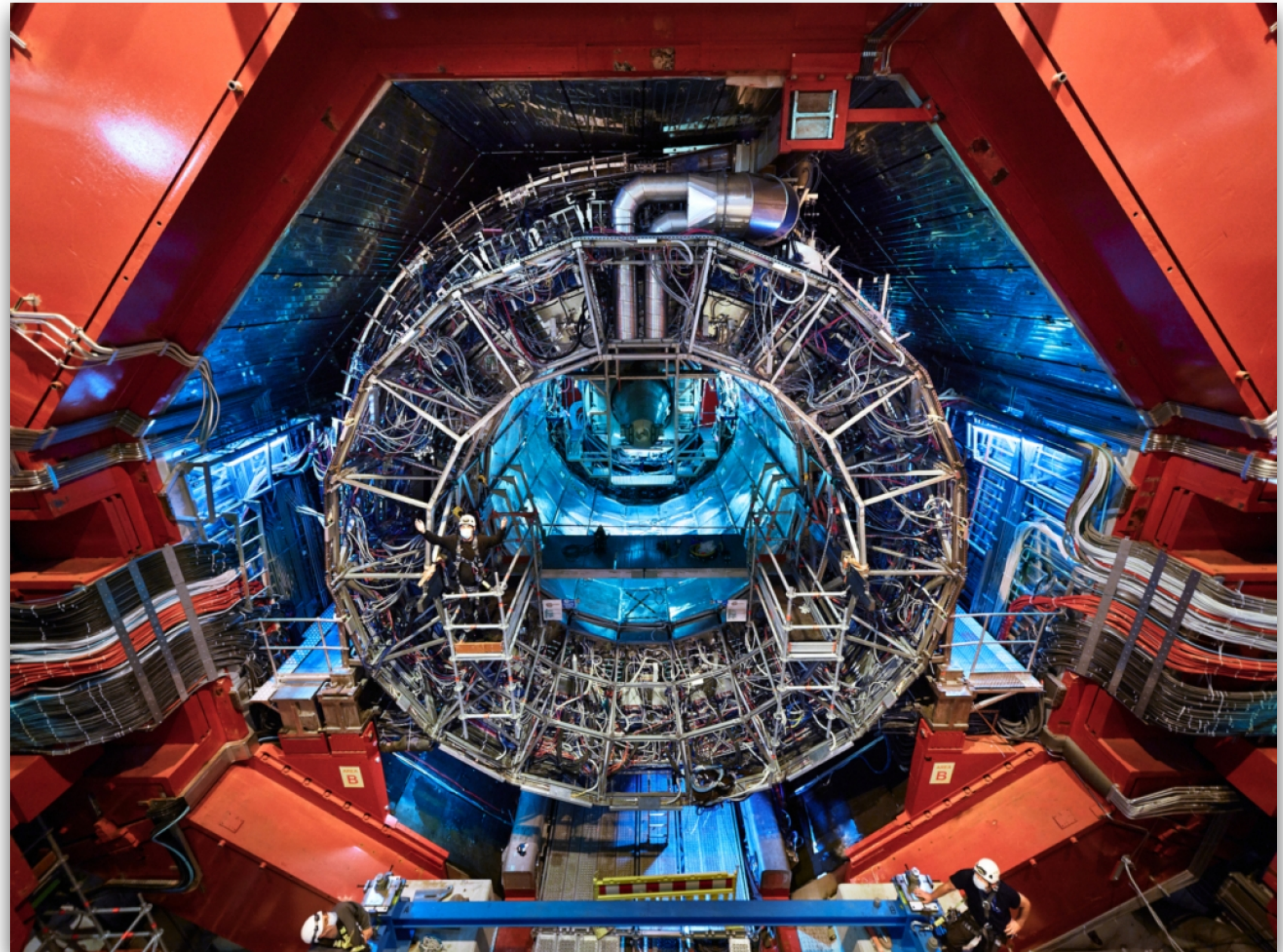

Heavy-ion collisions

[ALICE, EPJ C84 \(2024\) 813](#)

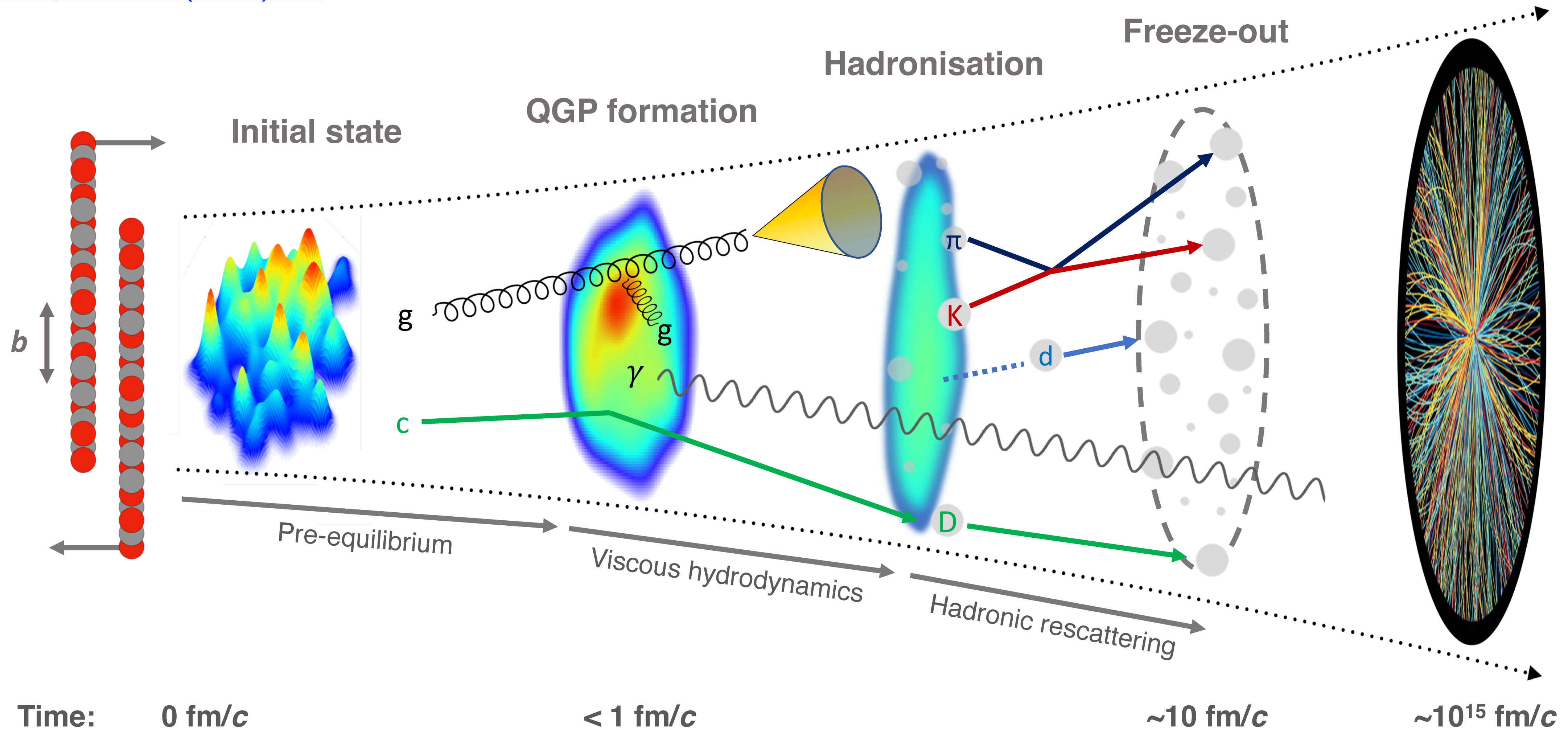

The ALICE Collaboration



38 countries, 164 institutes, 1819 members



Mexico:

45 members, 5 institutes



ALICE experiment at the LHC

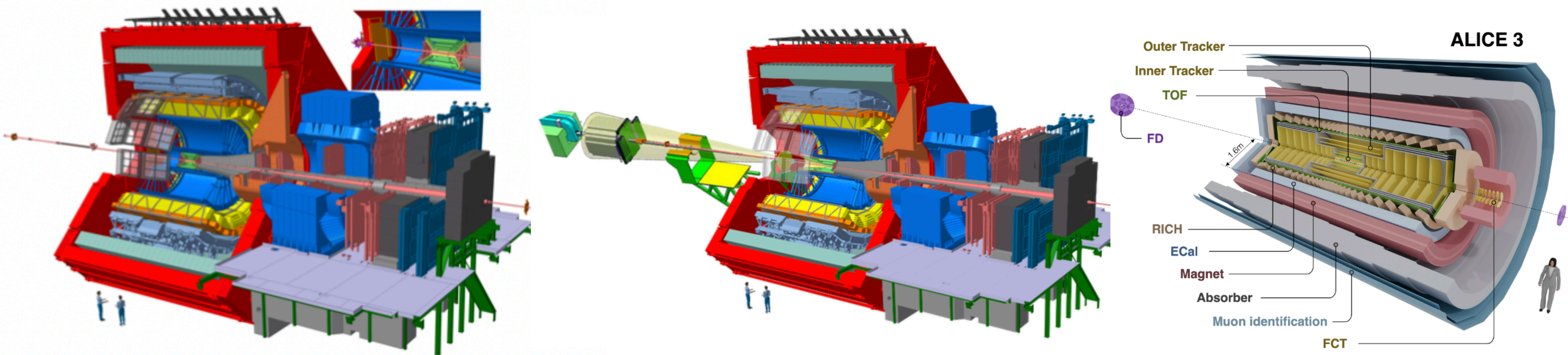
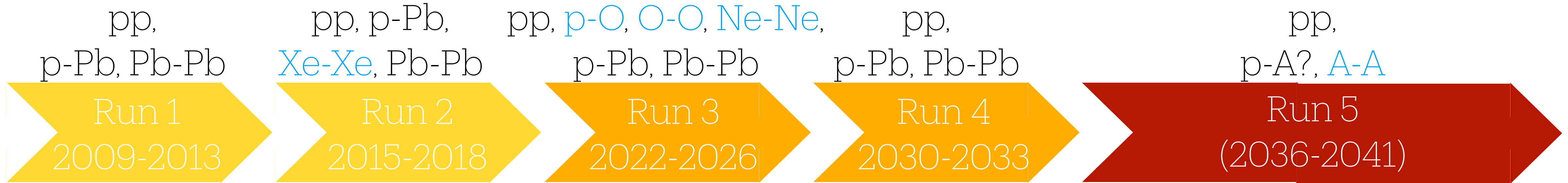

LS2 upgrade

Run 3
2022-2025

ALICE 2

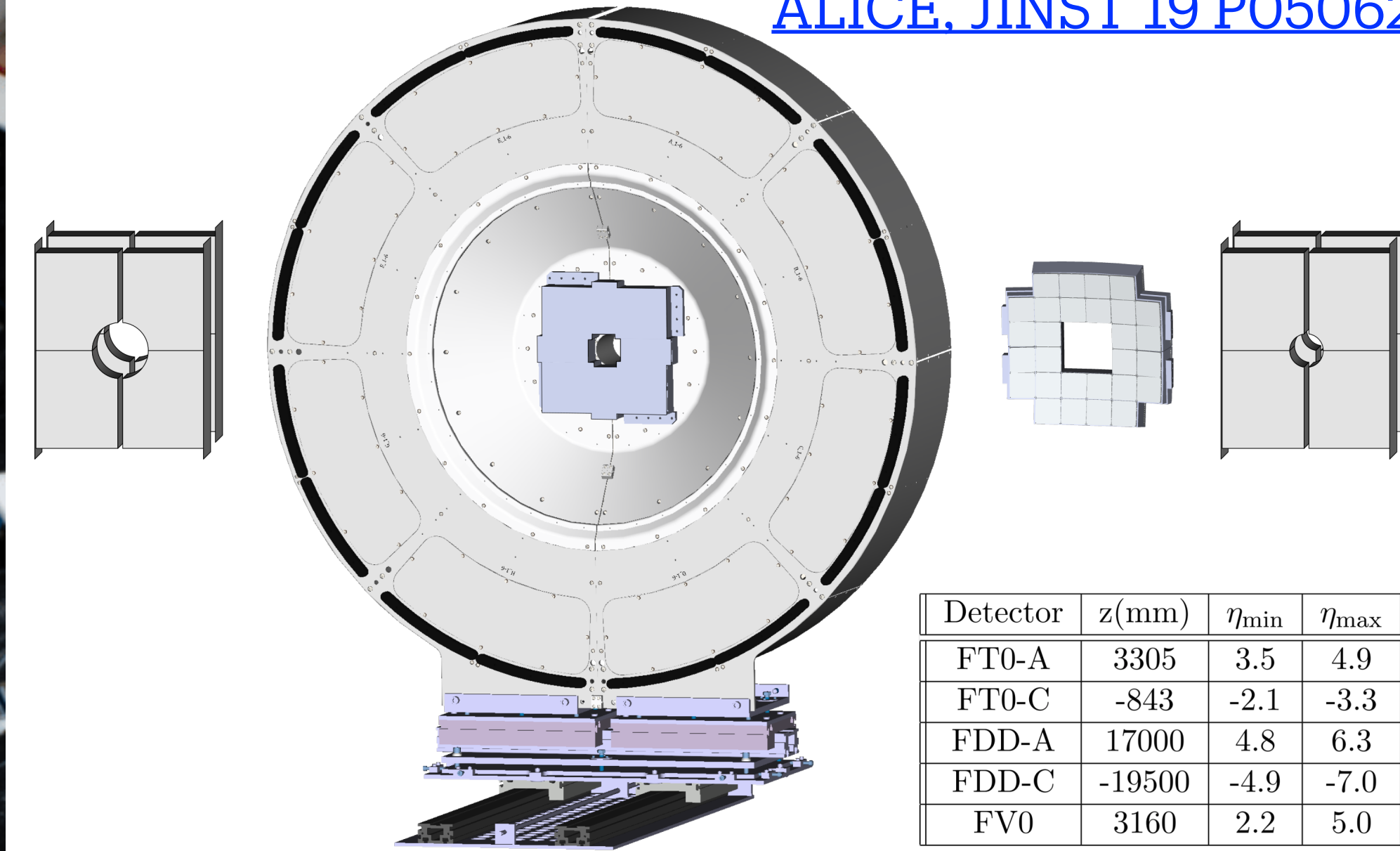
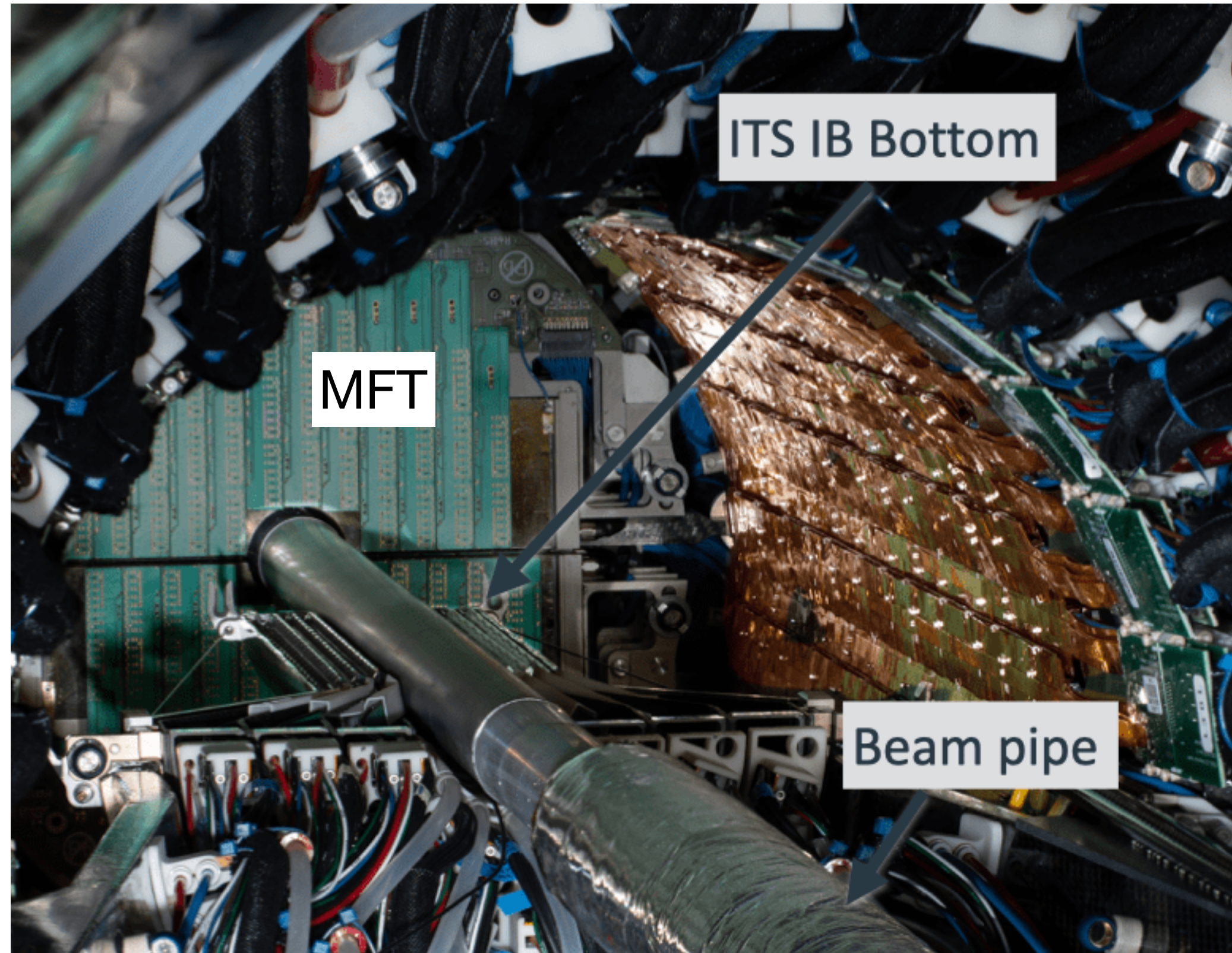

New Fast Interaction Trigger

- Inner Tracking System (ITS2): full pixel layers
- New Muon Forward Tracker (MFT)

continuous readout at high rate / Time Projection Chamber (GEM readout) / new event processing farm / Upgraded readout for most detectors

Run 3 data taking

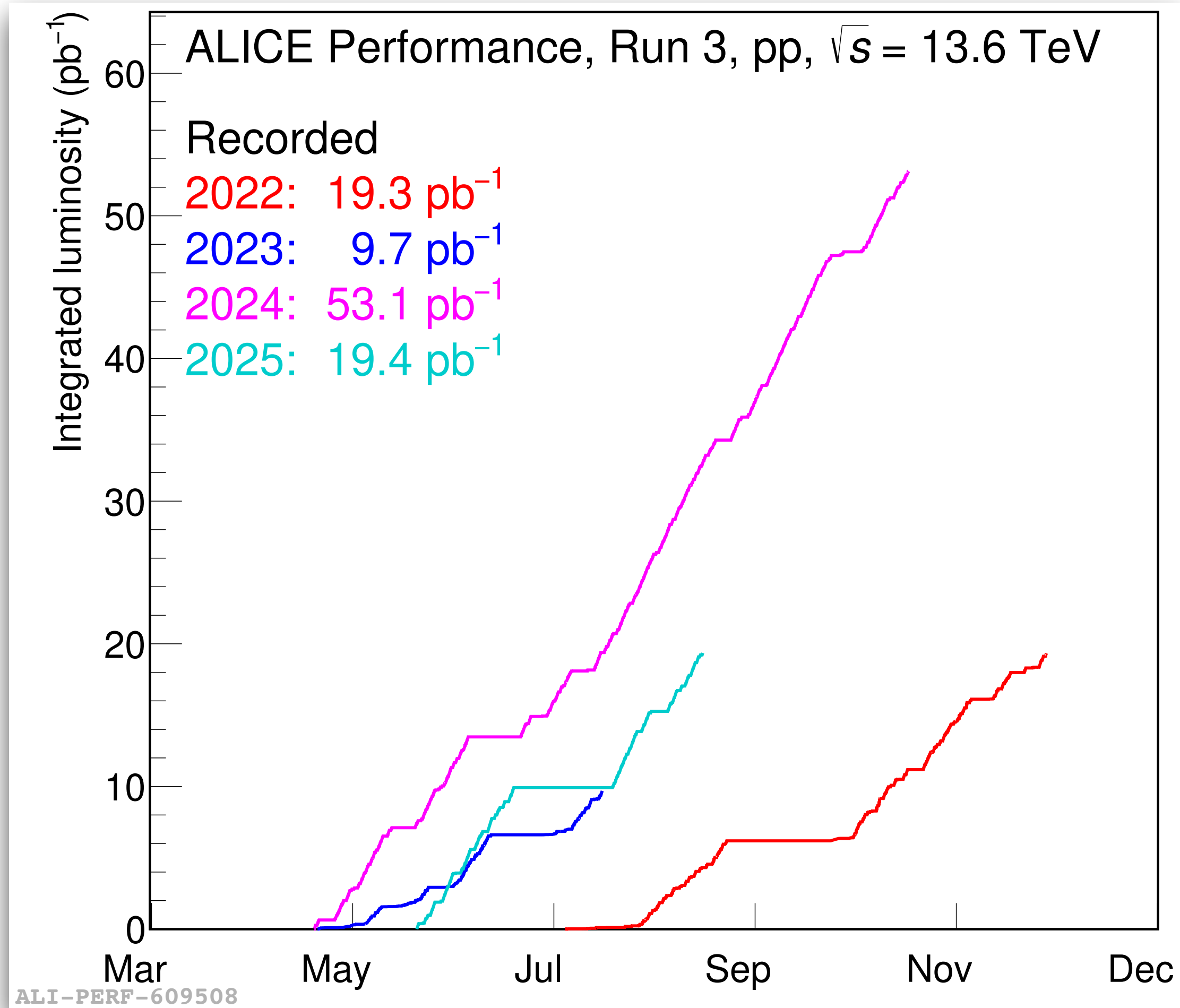

pp (2025): 19.4 pb⁻¹, efficiency: 95%

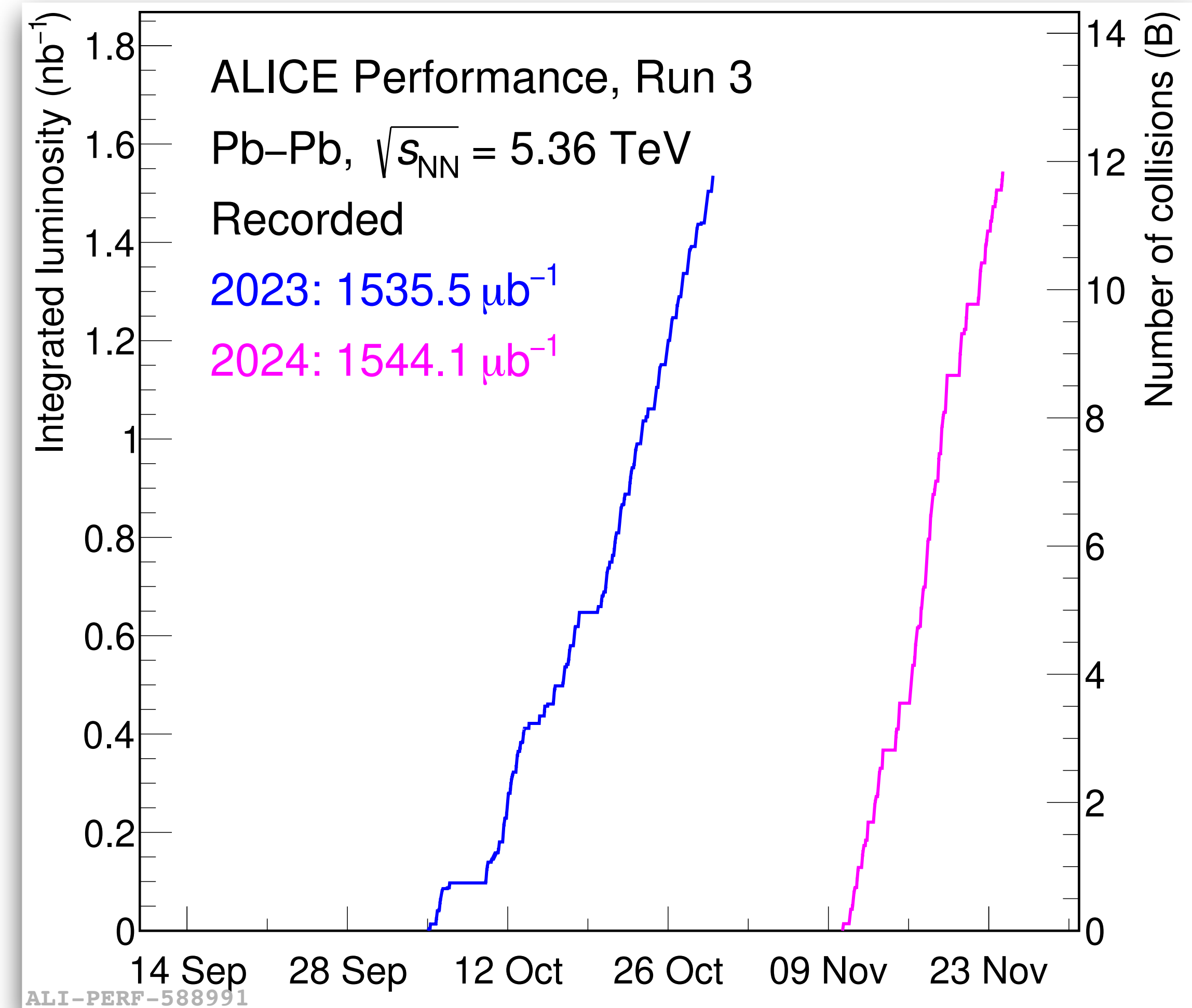

Heavy-ion run (2024): 1.6 nb⁻¹,
 $\approx 24 \times 10^9$ minimum-bias collisions

Charged particle pseudorapidity density

[ALICE, arXiv:2504.02505](https://arxiv.org/abs/2504.02505)

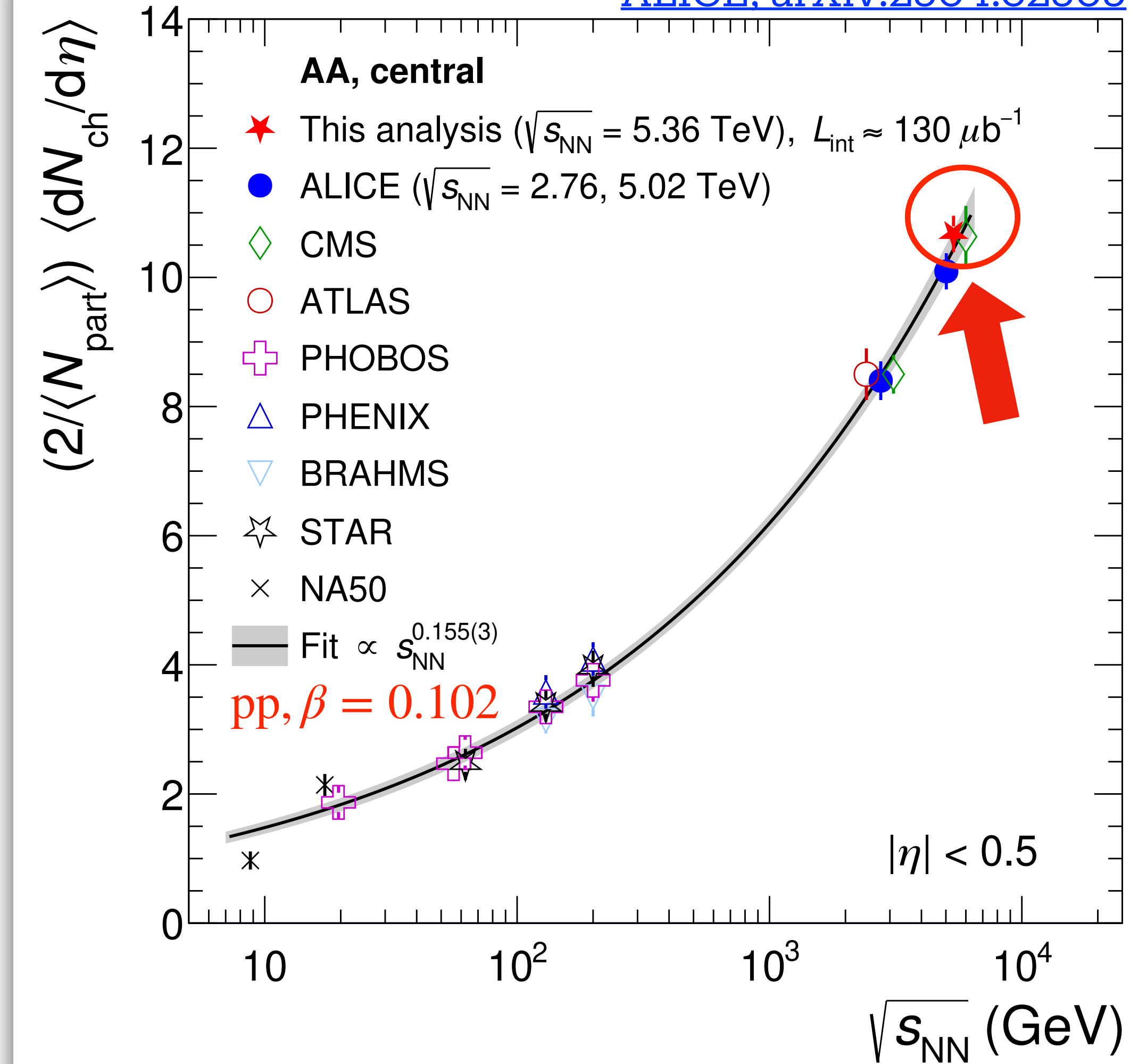

ALI-PUB-602543

Energy dependence in line with expectation from lower energies

Charged particle pseudorapidity density

ALICE, arXiv:2504.02505

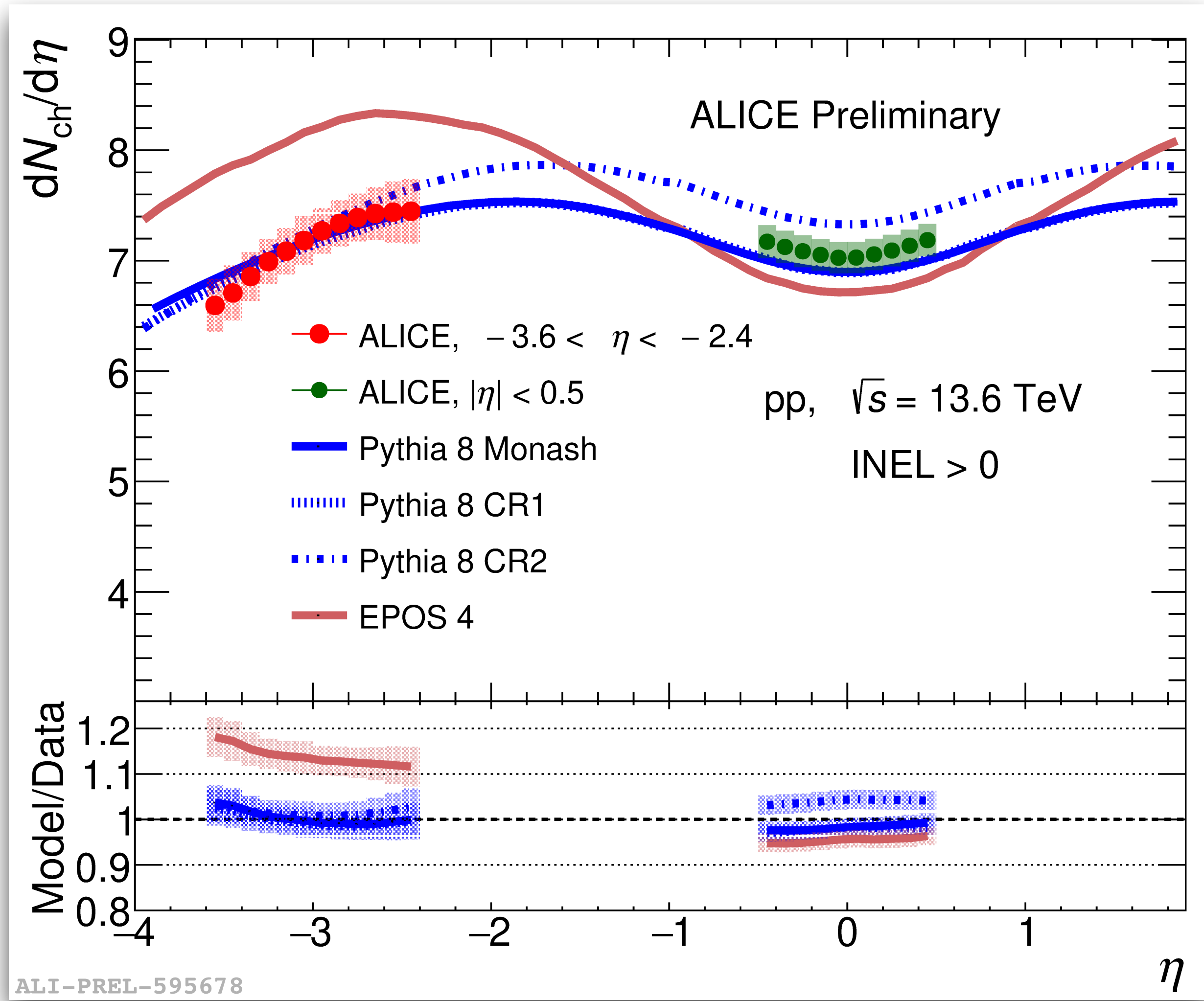
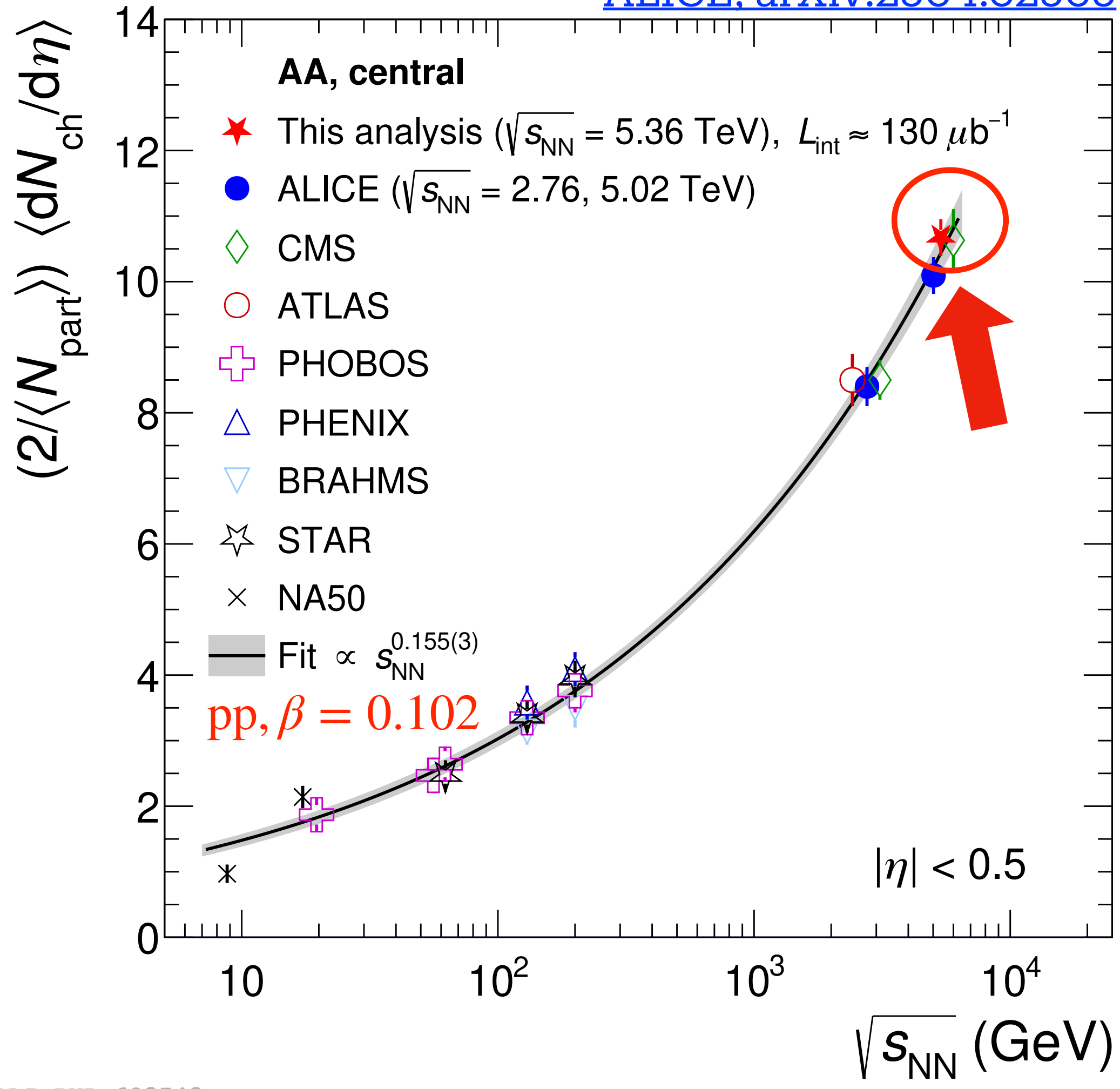

Energy dependence in line with expectation from lower energies

First measurement using the new MFT detector in pp collisions

The QGP expands: elliptic flow

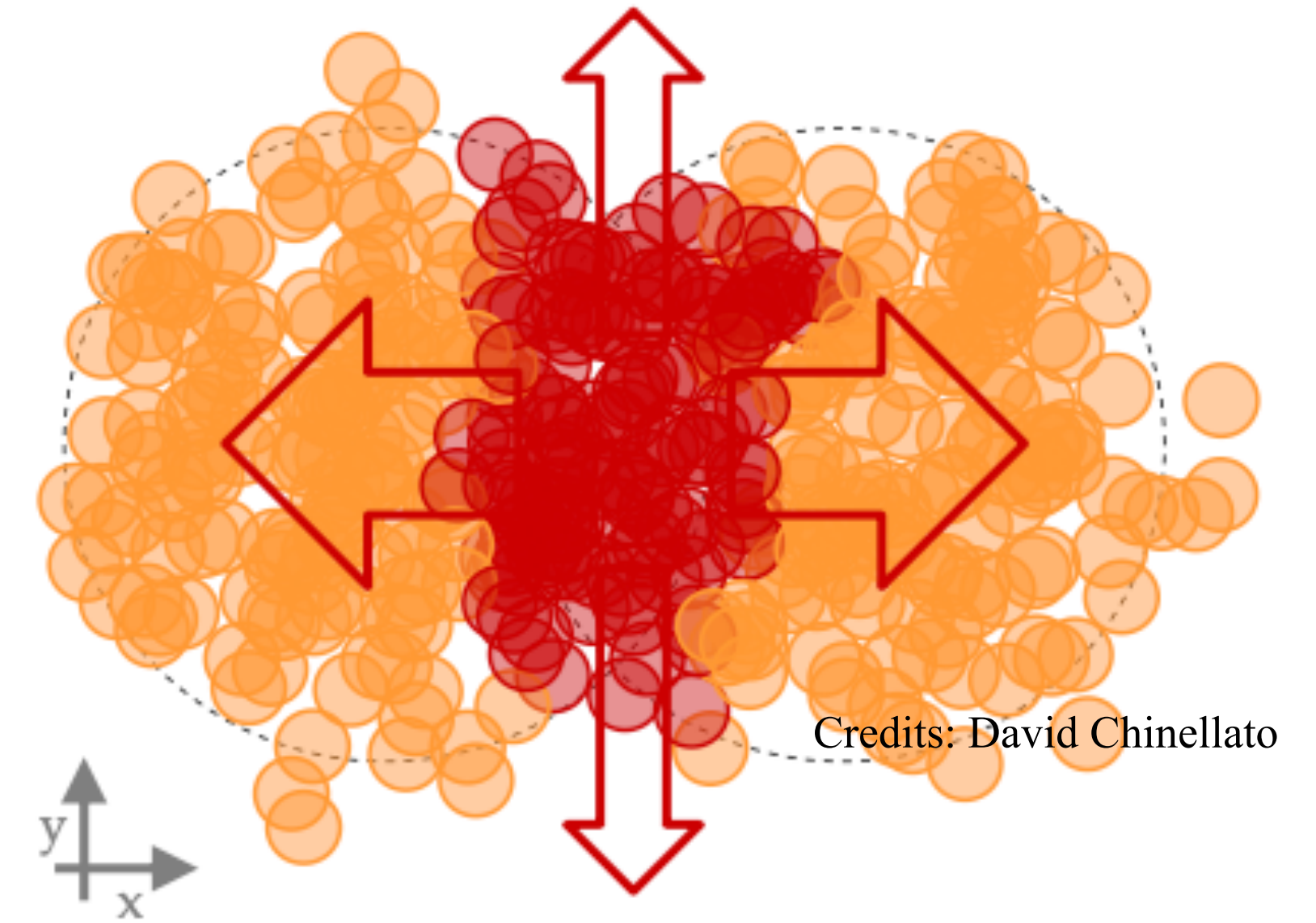
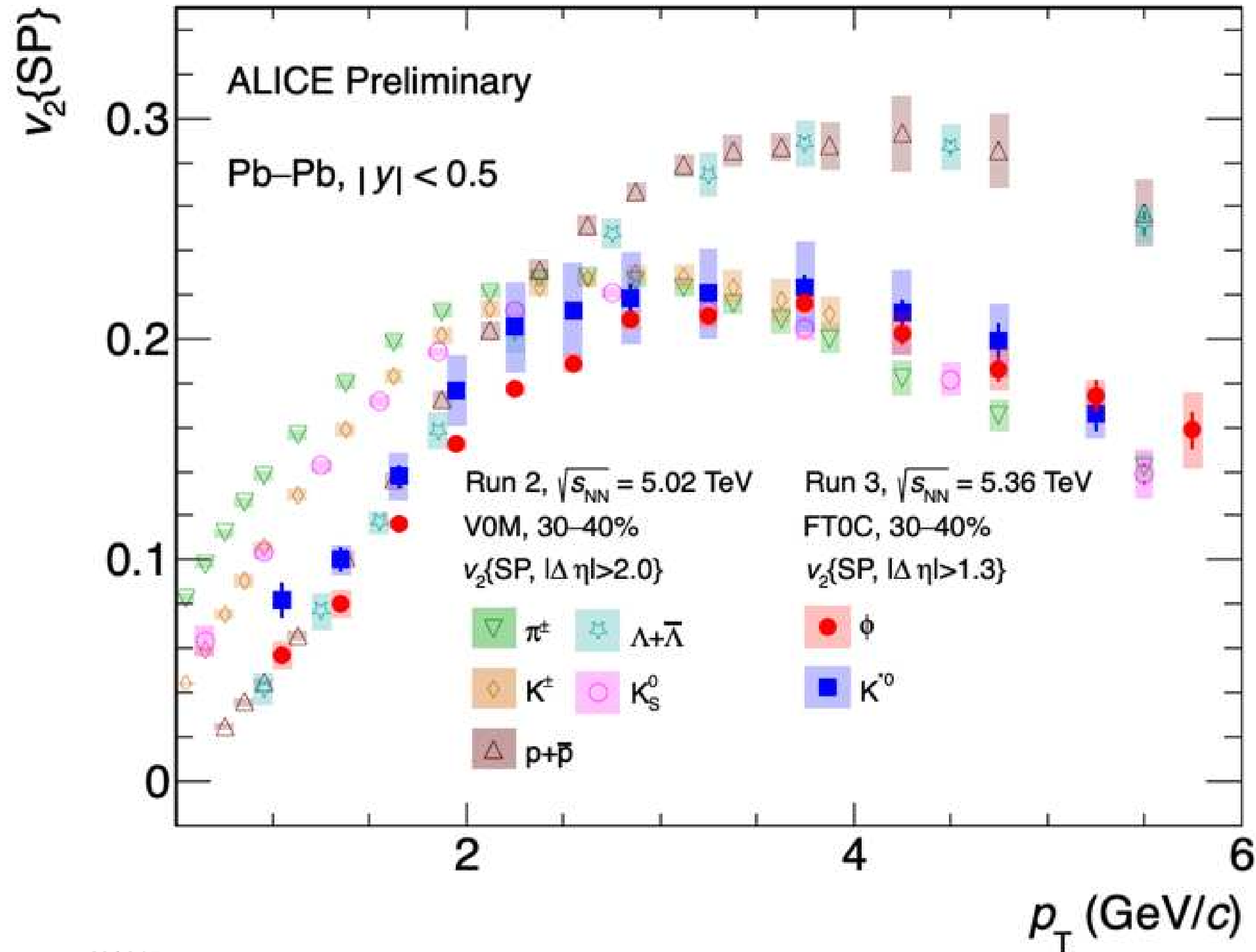

Light flavour sector: π^\pm , K^\pm , p , K_S^0 , Λ , ϕ , K^{*0}
 low p_T : mass-dependent
 → common velocity field
 high p_T : baryon/meson grouping
 → quark coalescence

Do charm quarks flow?

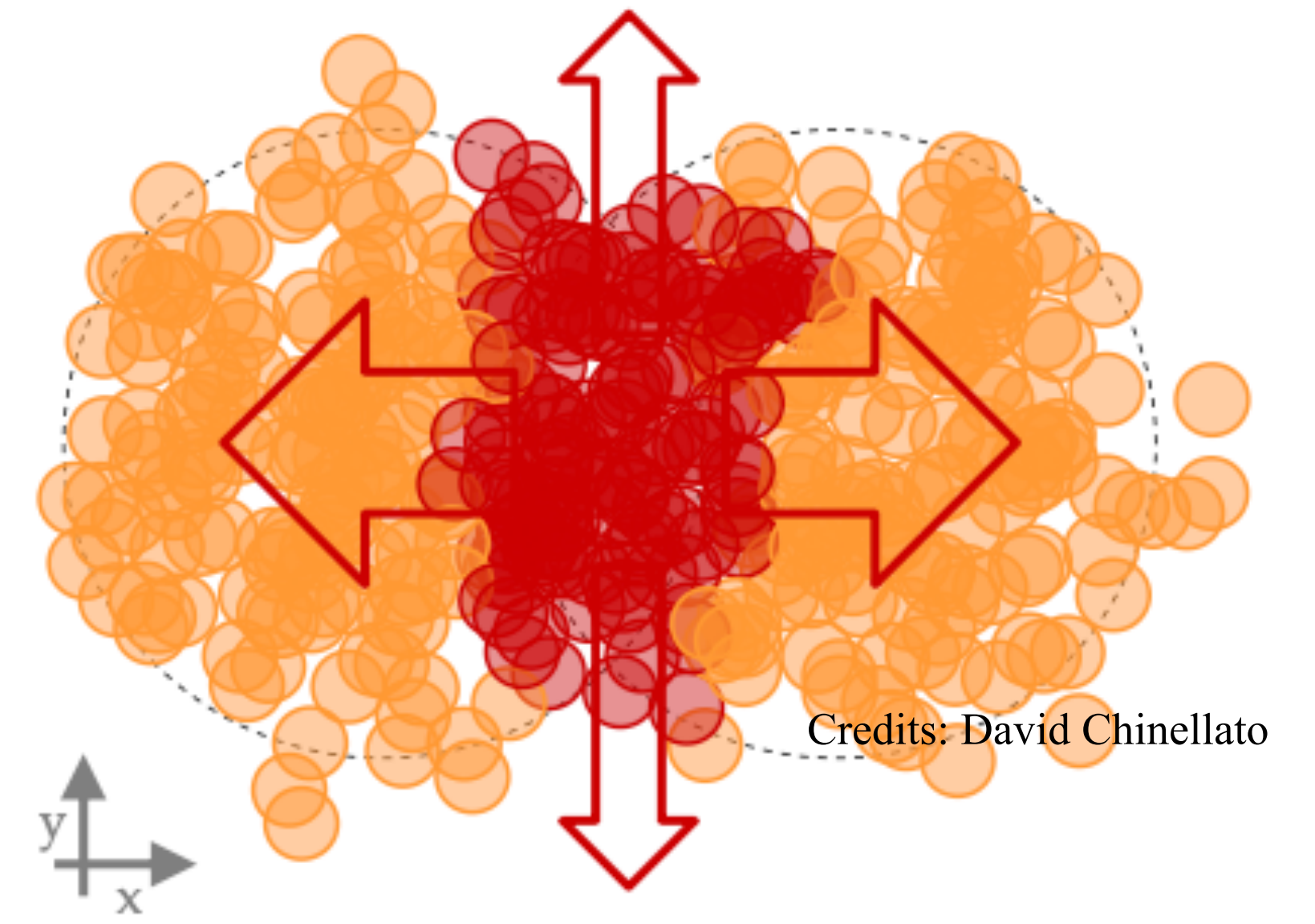
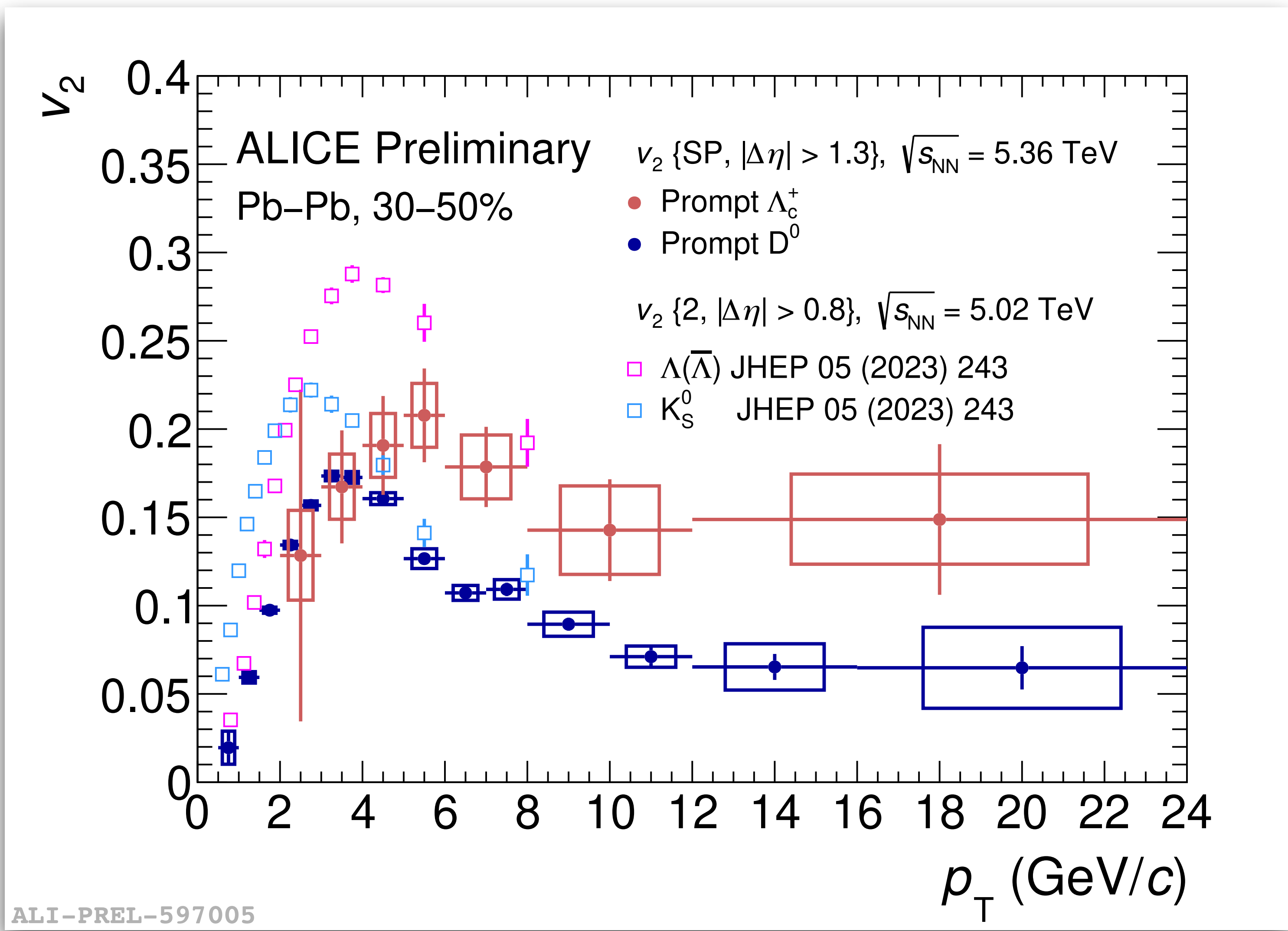

Significantly different vs D^0
 Similar effect seen in the light flavor sector (baryon/meson effect?)

Quark coalescence models describe trend

Small systems and light ions

Why are these systems interesting?

Paradigm 15 years ago

Small and large systems governed by totally different physics

Single-process limit
vacuum

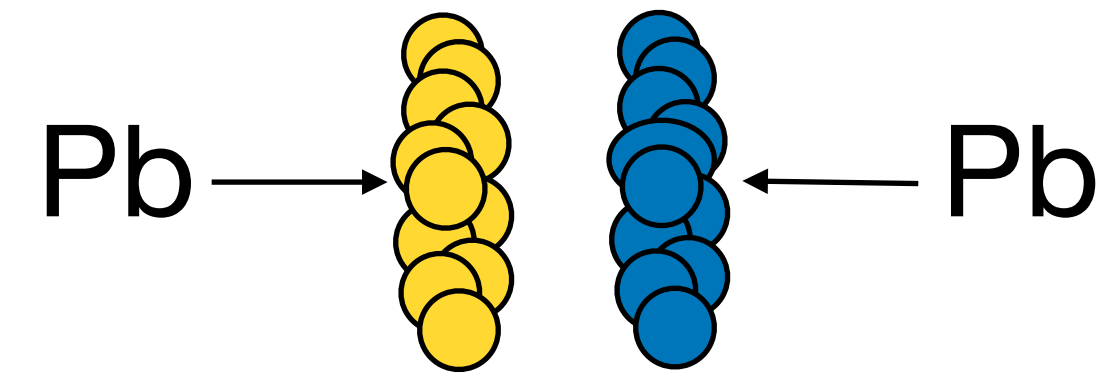

Thermal limit
dense QCD system

Why are these systems interesting?

Paradigm 15 years ago

Small and large systems governed by totally different physics

Single-process limit
vacuum

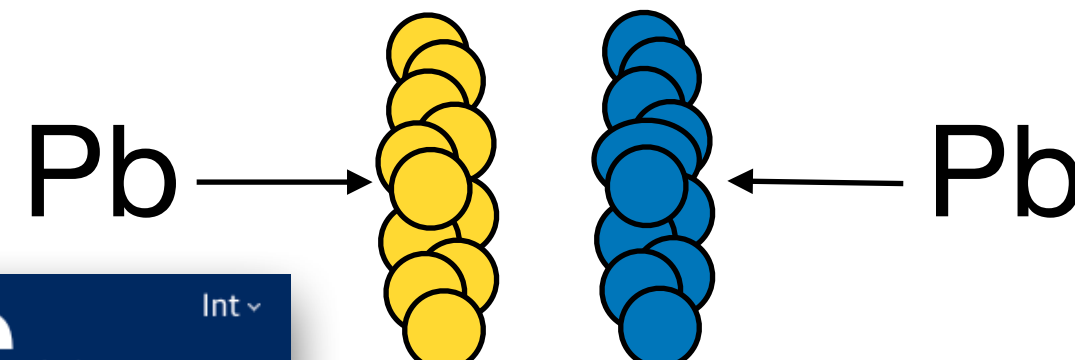

Thermal limit
dense QCD system

Discoveries at the LHC ...

Ridges are a direct consequence in hydrodynamic expansion description (flow in heavy-ion collisions)

Also seen in p-Pb collisions:

- [ALICE, PLB719 \(2013\) 29](#)
- [ATLAS, PRL110 \(2013\) 18, 182302](#)
- [CMS, PLB718 \(2013\) 795](#)
- [LHCb, PLB762 \(2016\) 473](#)

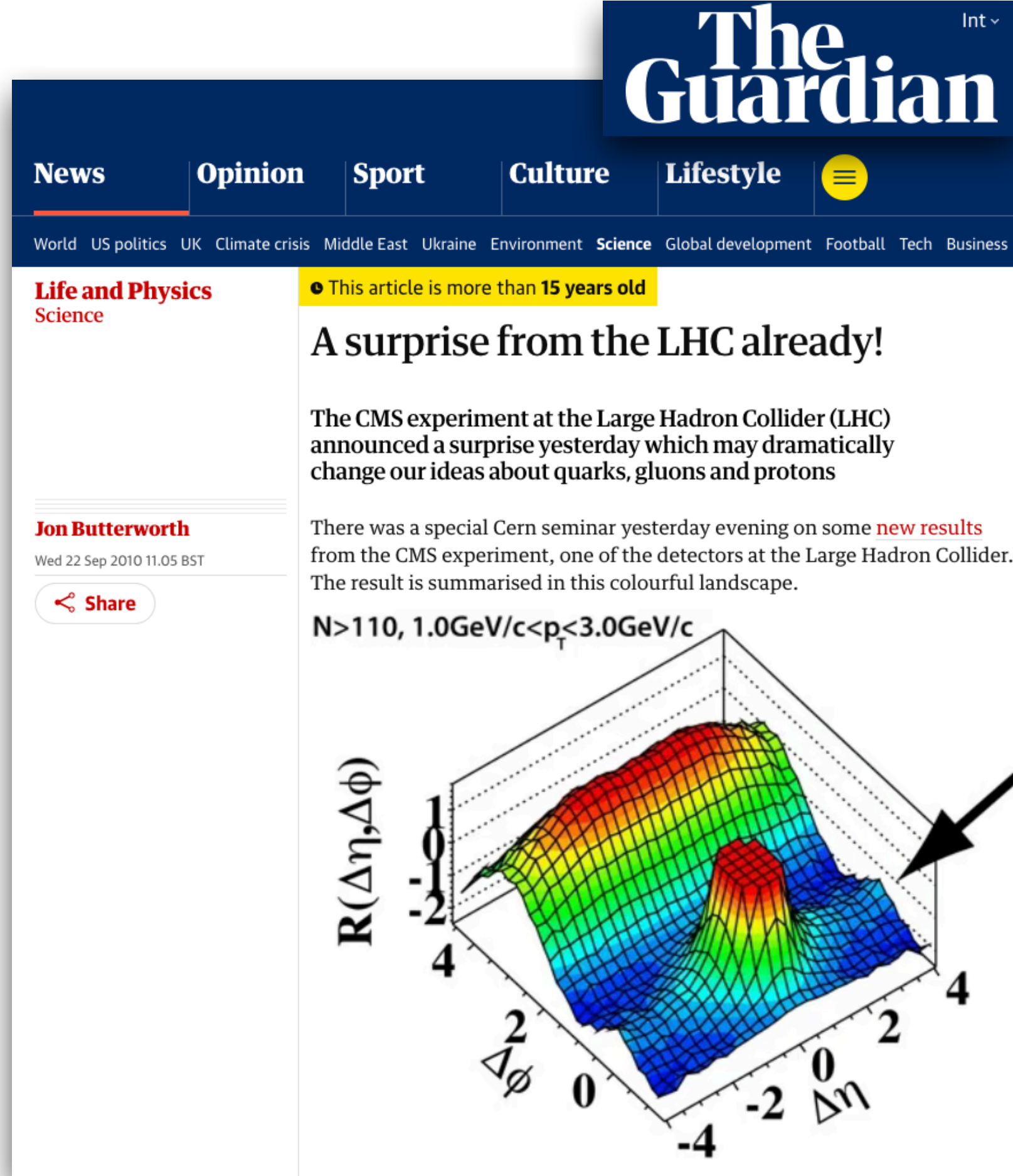

Why are these systems interesting?

Paradigm 15 years ago

Small and large systems governed by totally different physics

Single-process limit
vacuum

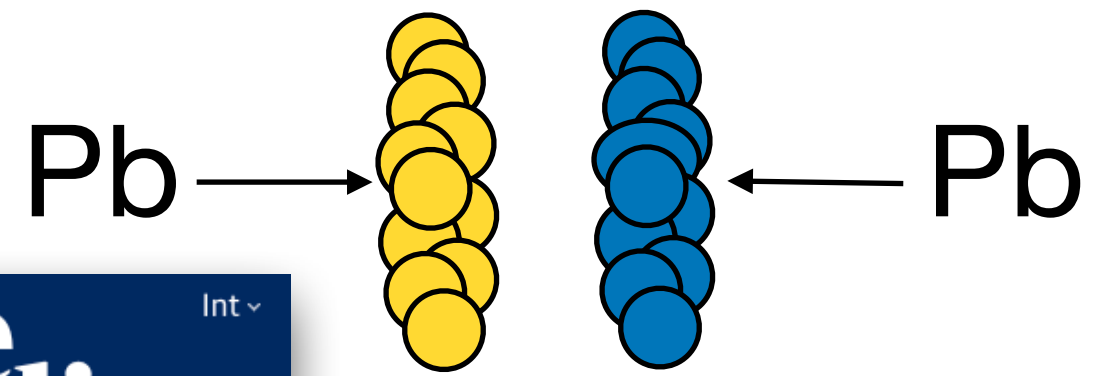

Thermal limit
dense QCD system

Discoveries at the LHC ...

Ridges are a direct consequence in hydrodynamic expansion description (flow in heavy-ion collisions)

Also seen in p-Pb collisions:

- [ALICE, PLB719 \(2013\) 29](#)
- [ATLAS, PRL110 \(2013\) 18, 182302](#)
- [CMS, PLB718 \(2013\) 795](#)
- [LHCb, PLB762 \(2016\) 473](#)

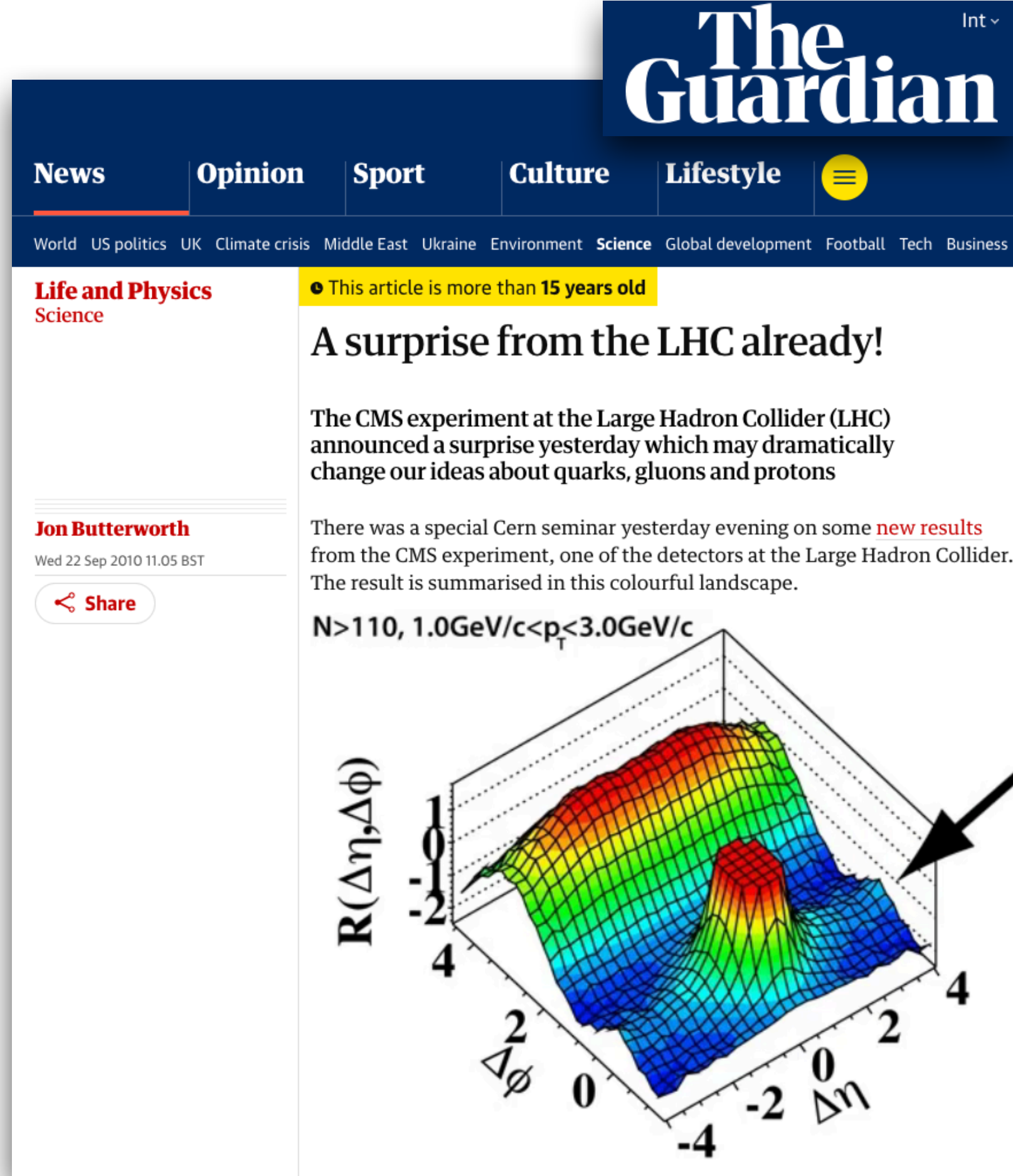

Strangeness enhancement

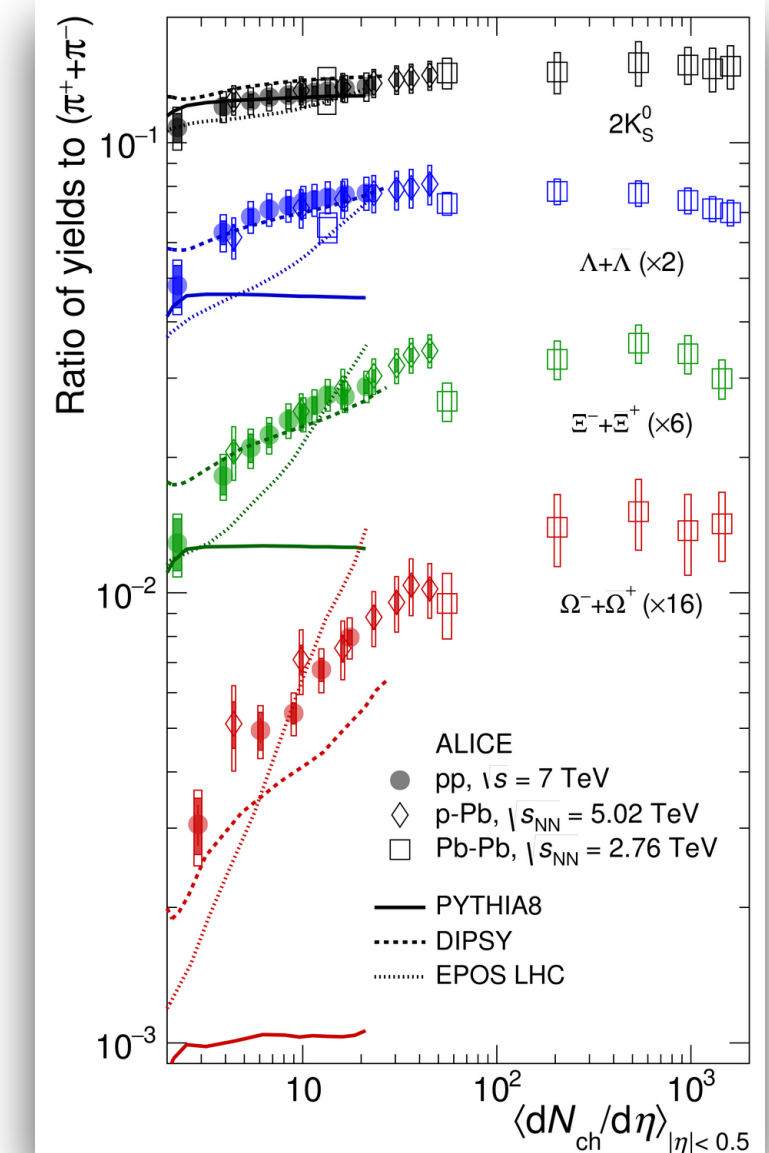
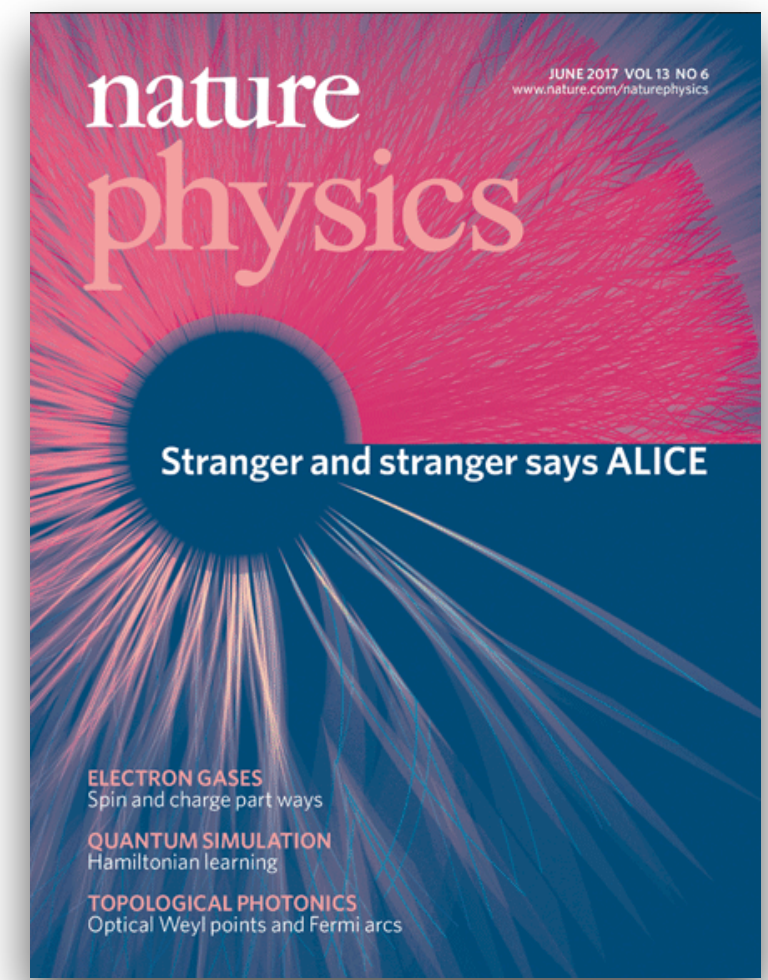

Historically, consequence of the temperature of the system

Ultra small systems

Present

Small and large systems governed by totally different physics

Single-process limit vacuum

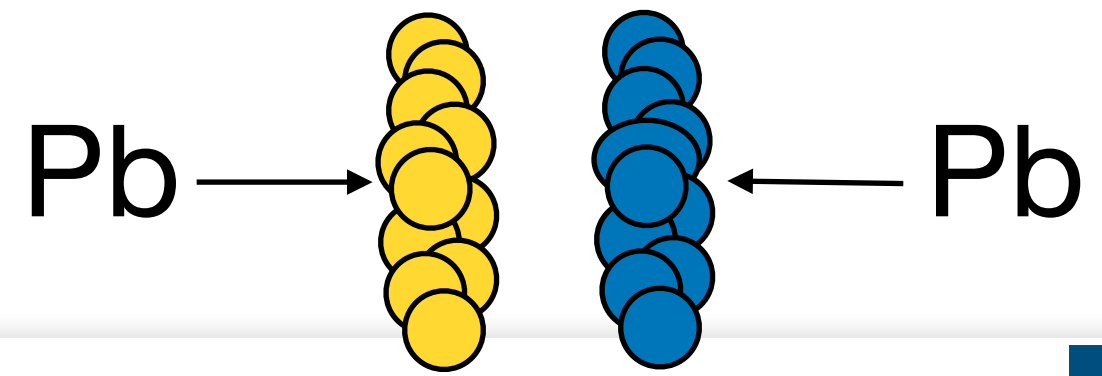

Thermal limit dense QCD system

Collective phenomena observed in large systems can be identified in high-multiplicity pp and p-Pb collisions

- o What about more dilute systems ? e.g. low multiplicity pp and UPC

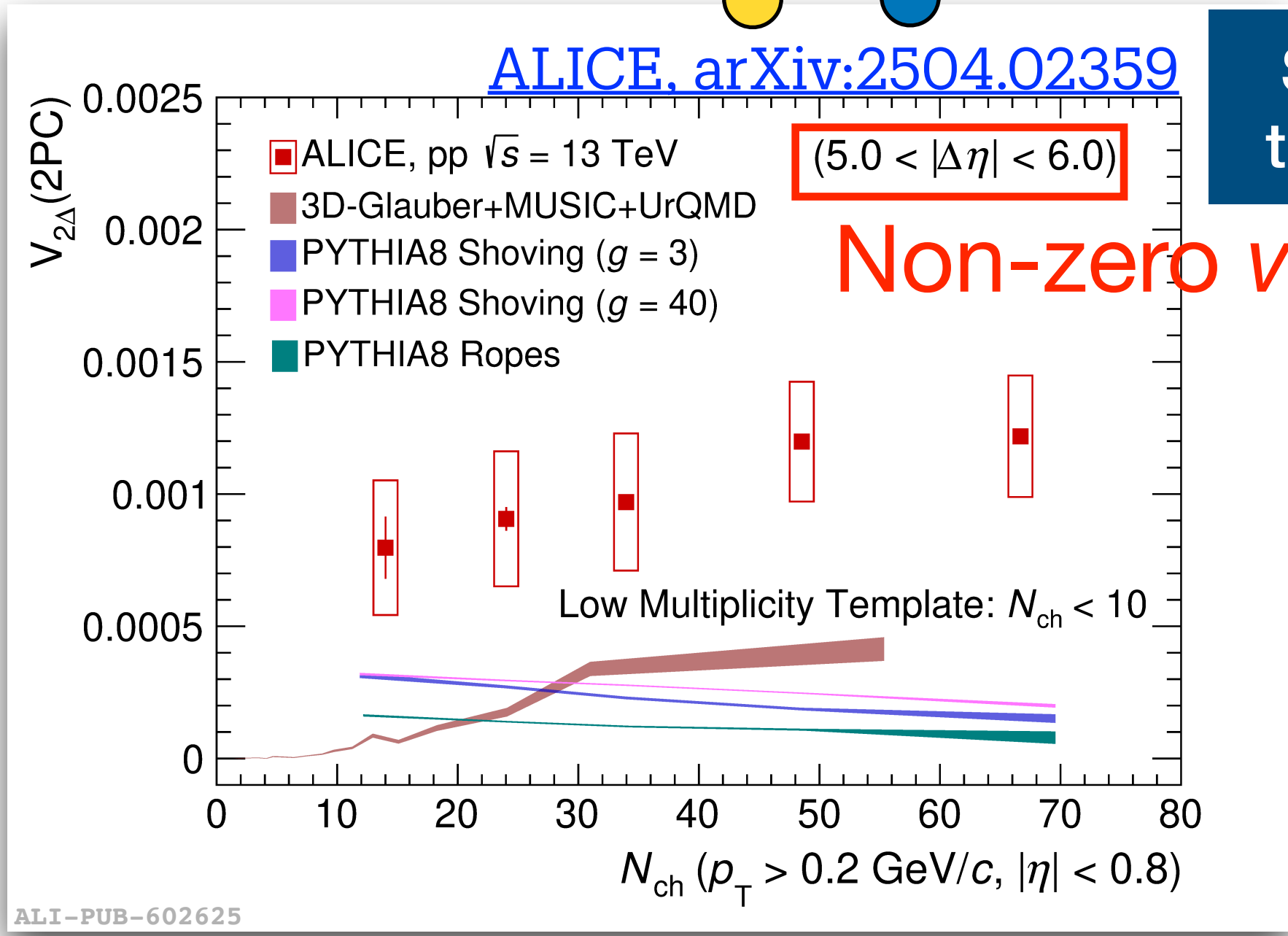

See Dushmanta Sahu talk: 22/10/2025, 17:45

(Ultra)small systems

Present

Small and large systems governed by totally different physics

Single-process limit
vacuum

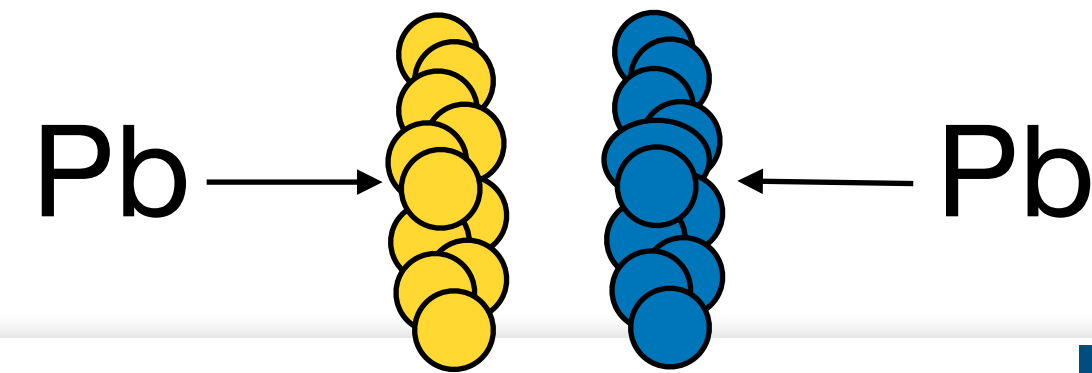

Thermal limit
dense QCD system

Collective phenomena observed in large systems can be identified in high-multiplicity pp and p-Pb collisions

- What about more dilute systems ? e.g. low multiplicity pp and UPC

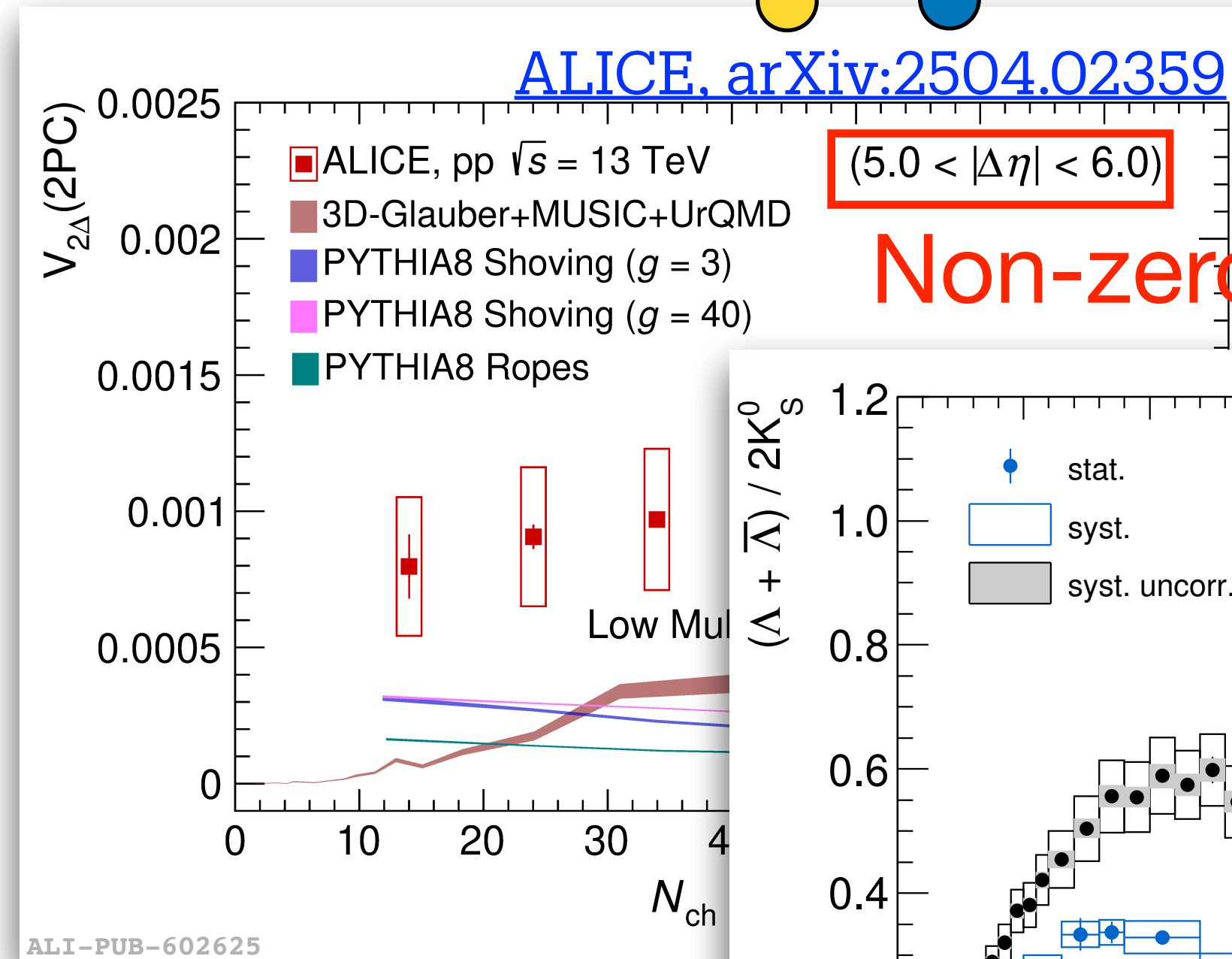

See Dushmanta Sahu talk: 22/10/2025, 17:45

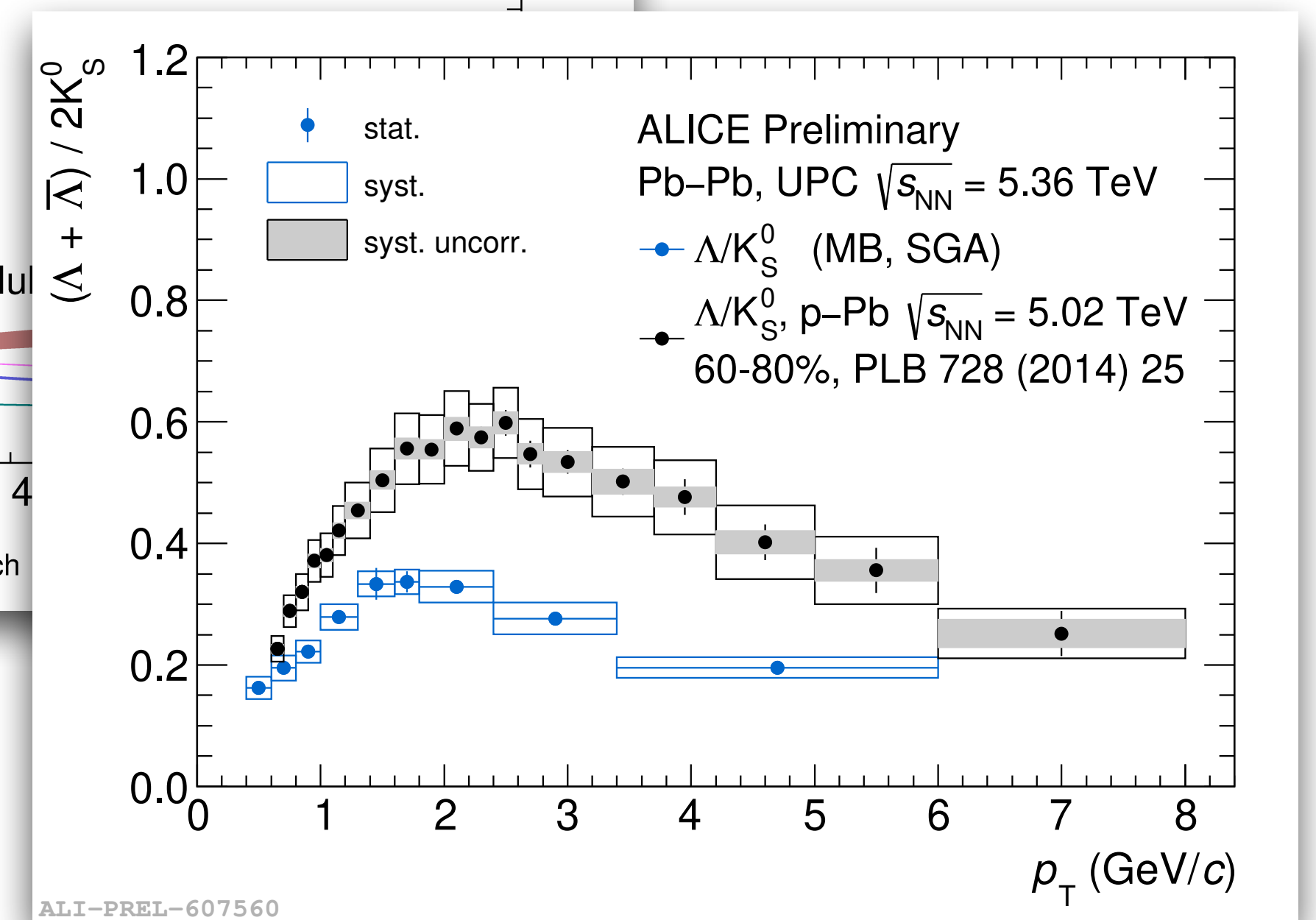

Λ/K_S^0 enhancement in $\gamma - Pb$ 17

(Ultra)small systems

Present

Small and large systems governed by totally different physics

Single-process limit
vacuum

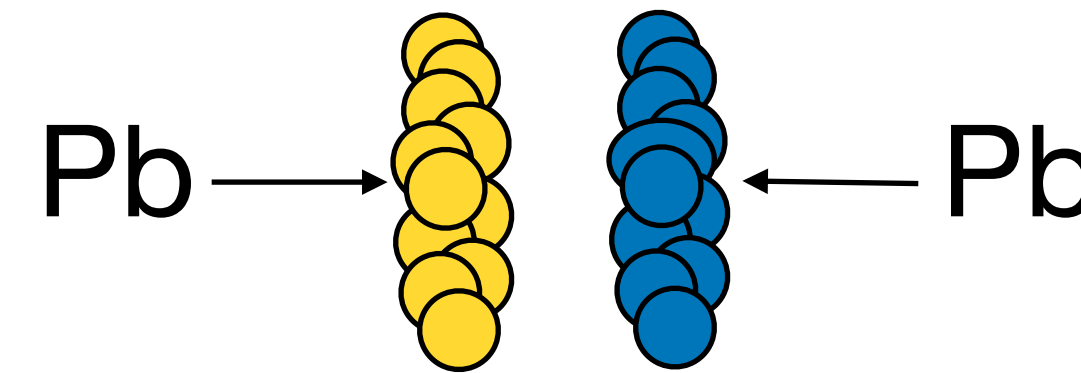

Thermal limit
dense QCD system

Collective phenomena observed in large systems can be identified in high-multiplicity pp and p-Pb collisions

- What about more dilute systems ?
e.g. low multiplicity pp and UPC

If collective phenomena are due to parton-parton interactions, then we must observe the effects of the parton-parton interactions

- Can we measure energy loss in small systems?

[ALICE, JHEP 05 \(2024\) 229](#)

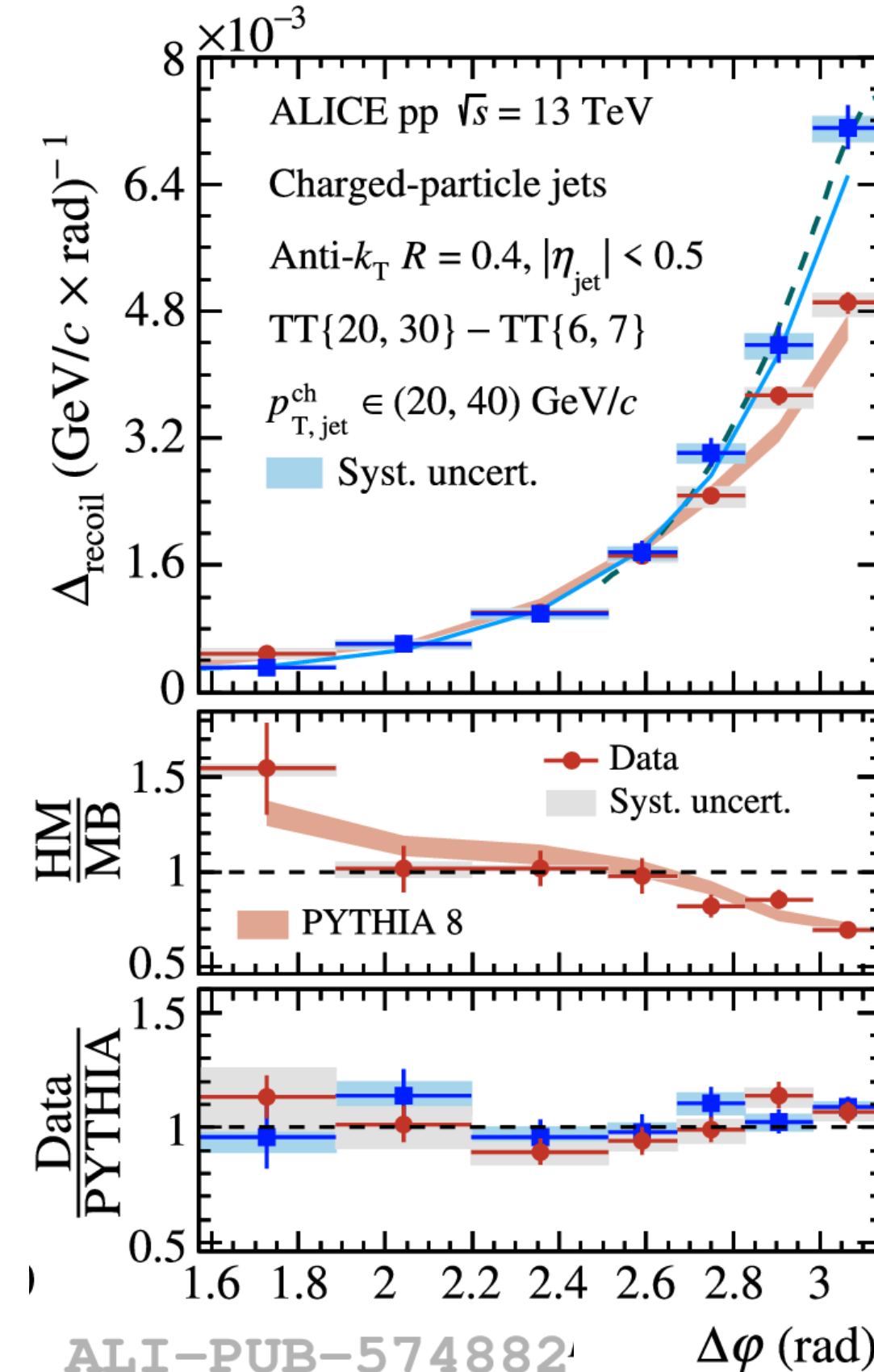

Selection bias
produces fake jet
quenching effects

(Ultra)small systems

Present

Small and large systems governed by totally different physics

Single-process limit
vacuum

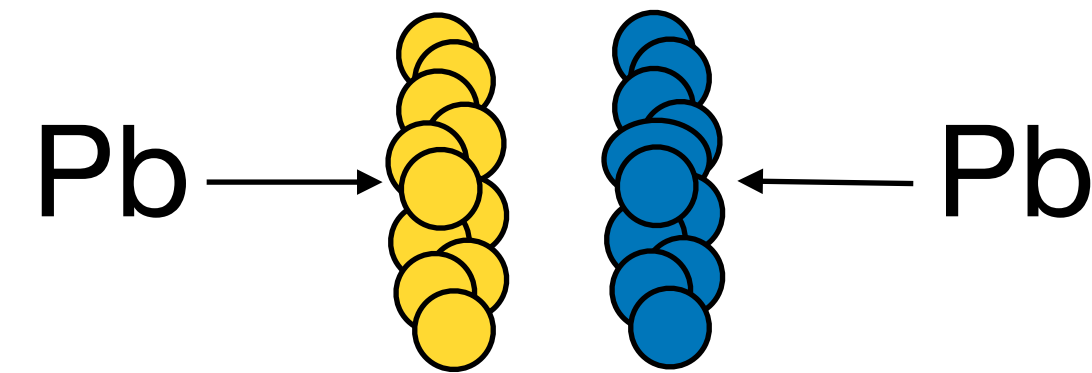

Thermal limit
dense QCD system

Collective phenomena observed in large systems can be identified in high-multiplicity pp and p-Pb collisions

- What about more dilute systems ?
e.g. low multiplicity pp and UPC

If collective phenomena are due to parton-parton interactions, then we must observe the effects of the parton-parton interactions

- Can we measure energy loss in small systems?

[ALICE, JHEP 05 \(2024\) 229](#)

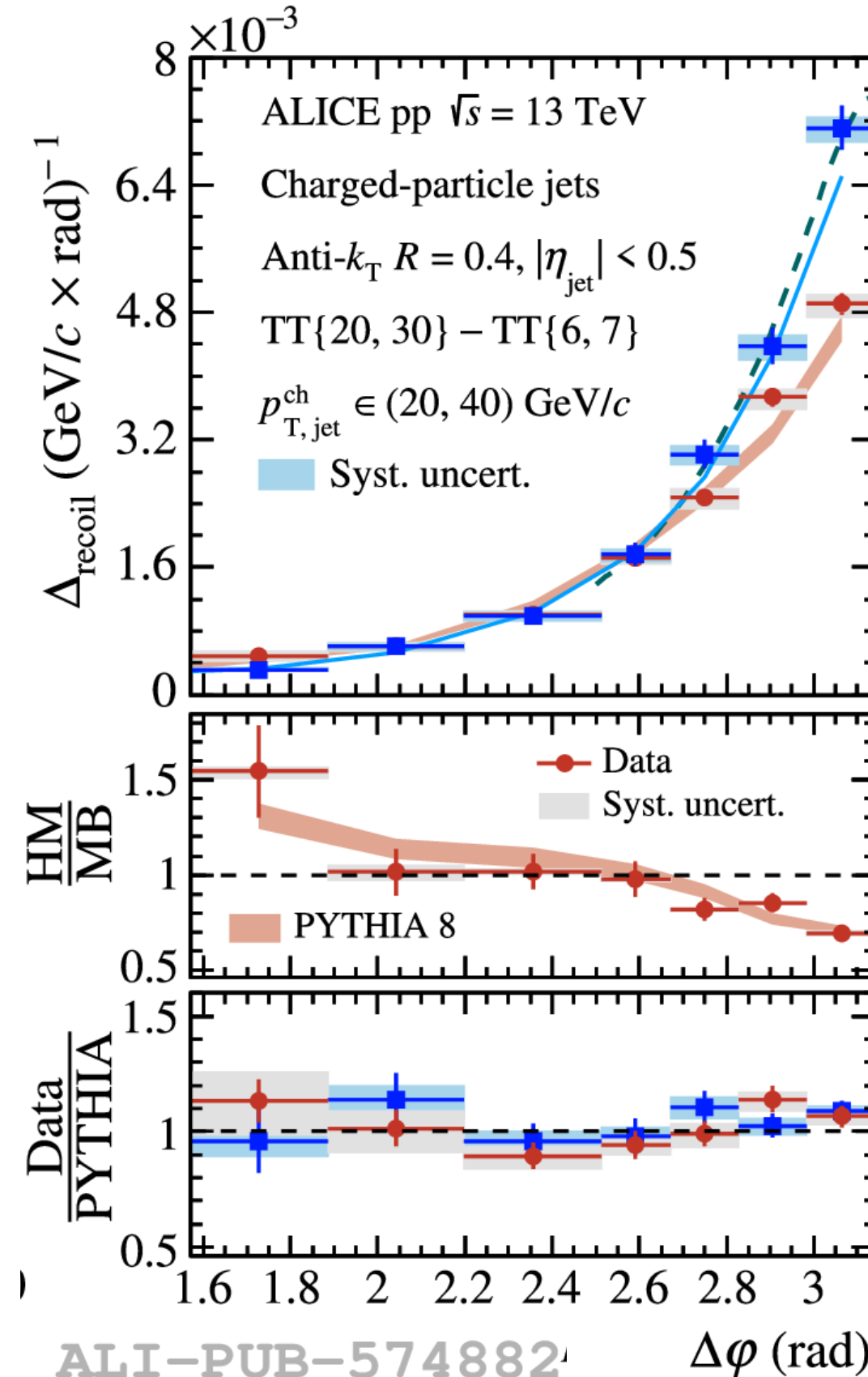

Flattenicity is a promising venue to explore the effects

[A. Ortiz et al., PRD 107 \(2023\) 076012](#)

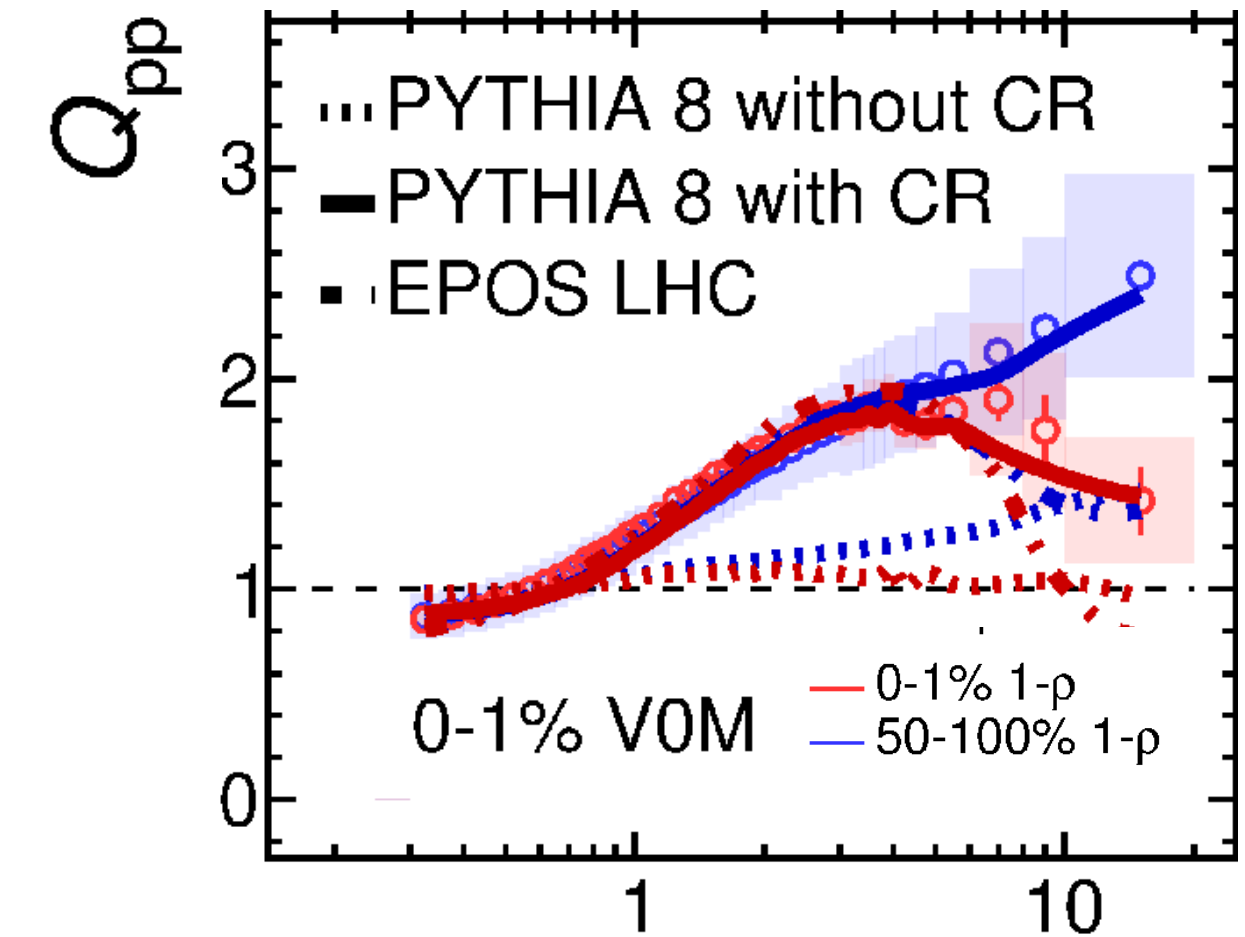

ALI-PUB-589552

[ALICE, PRD 111 \(2025\) 012010](#)

Filling the multiplicity gap (light ions)

Present

Small and large systems governed by totally different physics

Single-process limit vacuum

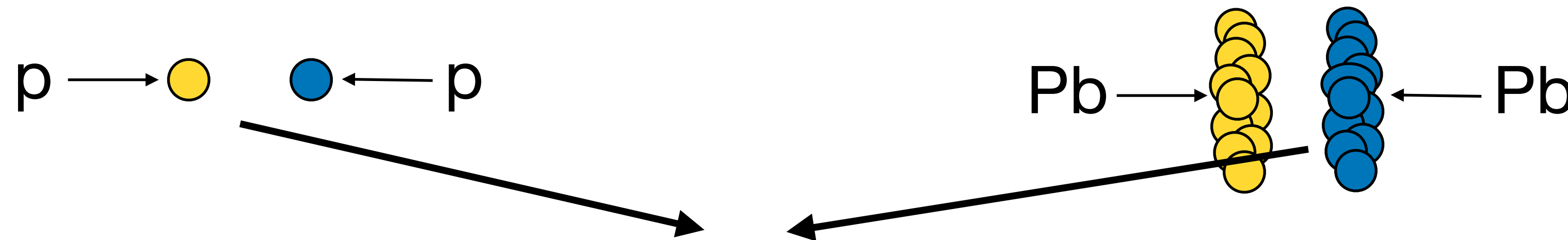

Thermal limit dense QCD system

$$R_{AA} = \frac{dN^{AA}/dp_T}{\langle N_{coll} \rangle dN^{pp}/dp_T}$$

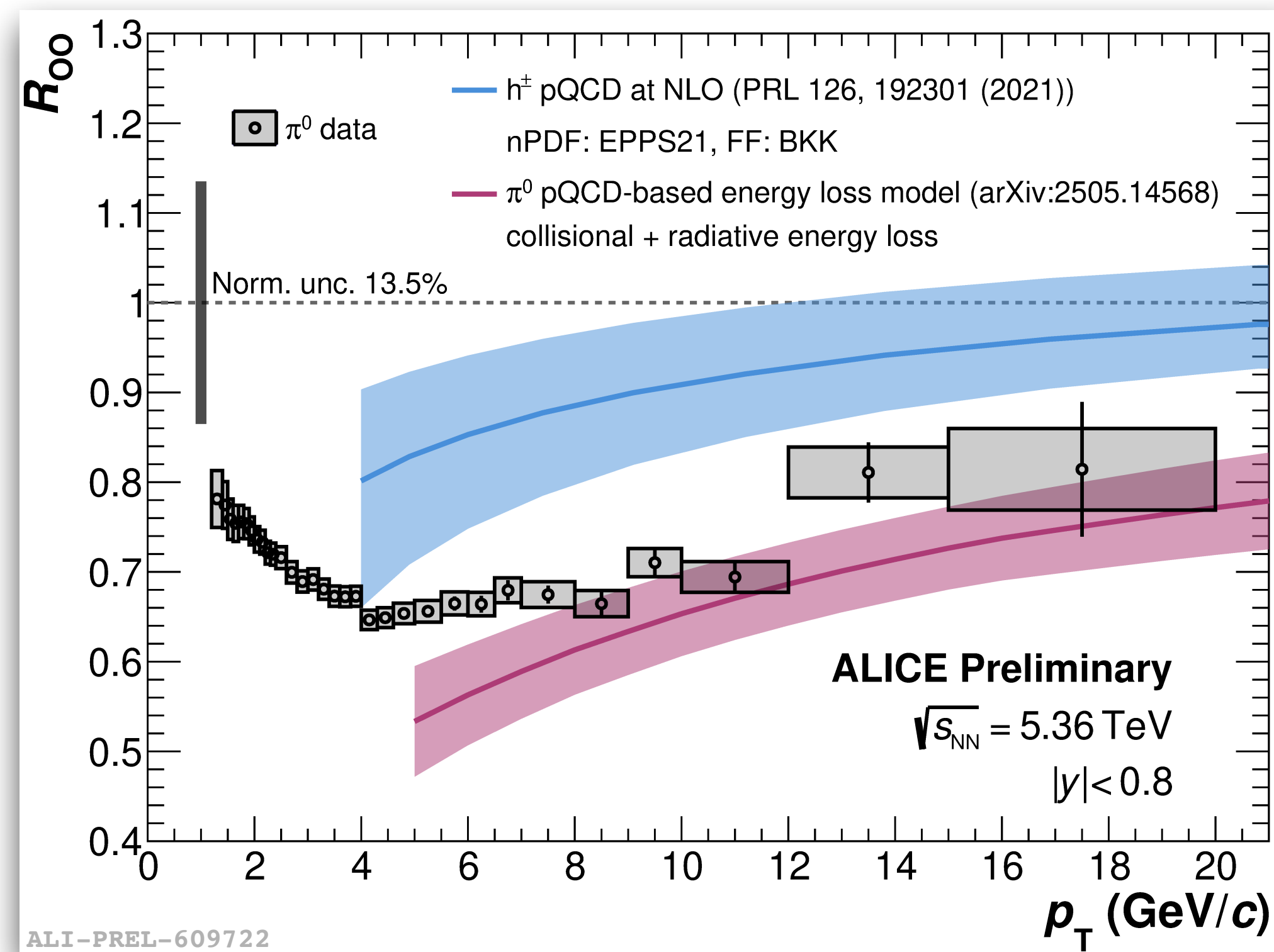

Large uncertainties, whether we see parton-energy loss in O-O collisions to be answered in the next months

Upgrades

Timeline of ALICE upgrades



LS3: FoCal & ITS3

- Specific upgrades for Run 4
- TDRs approved in March 2024
- Now proceeding towards final sensors in view of start of production

LS4: ALICE 3

- New detector for Run 5
- Lol reviewed in 2022
- SD reviewed March 2025

FoCal TDR: [CERN-LHCC-2024-004](https://cds.cern.ch/record/2824004)

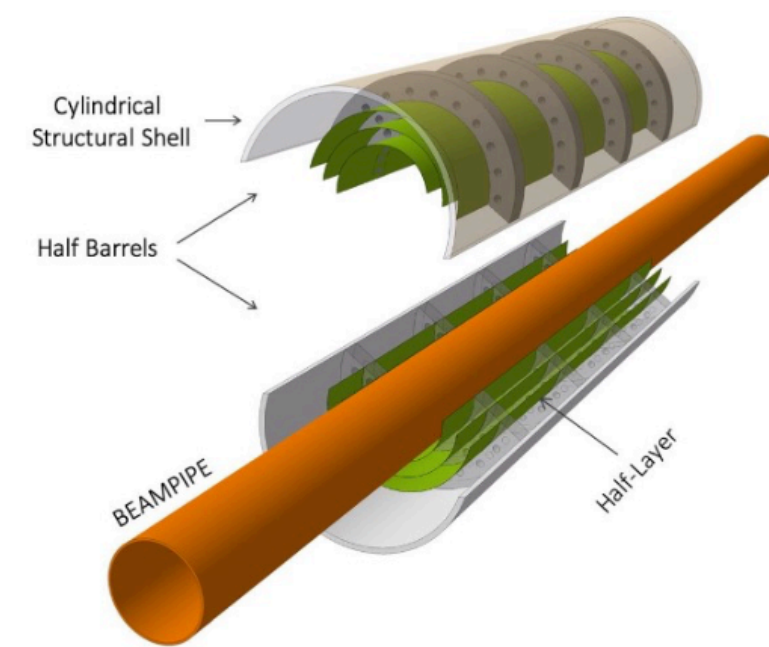
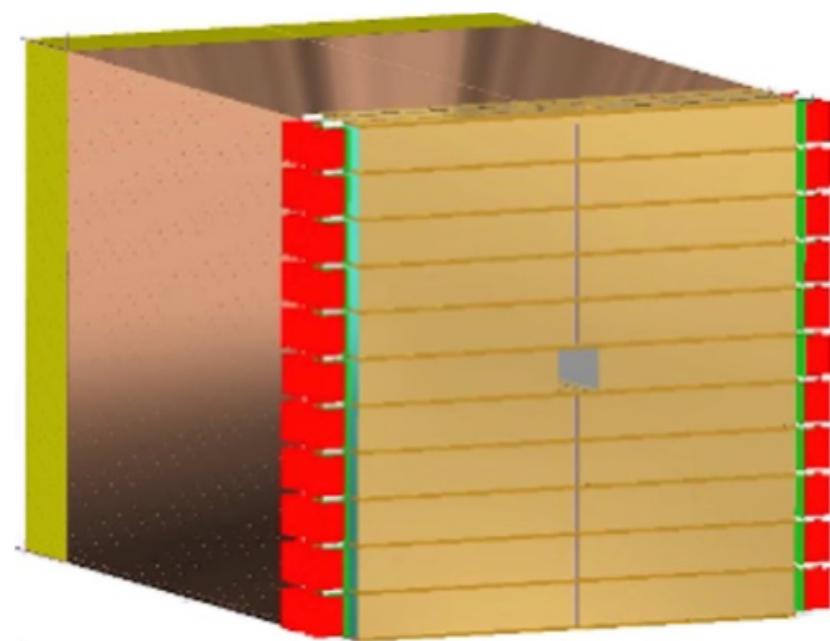

ITS3 TDR: [CERN-LHCC-2024-003](https://cds.cern.ch/record/2824003)

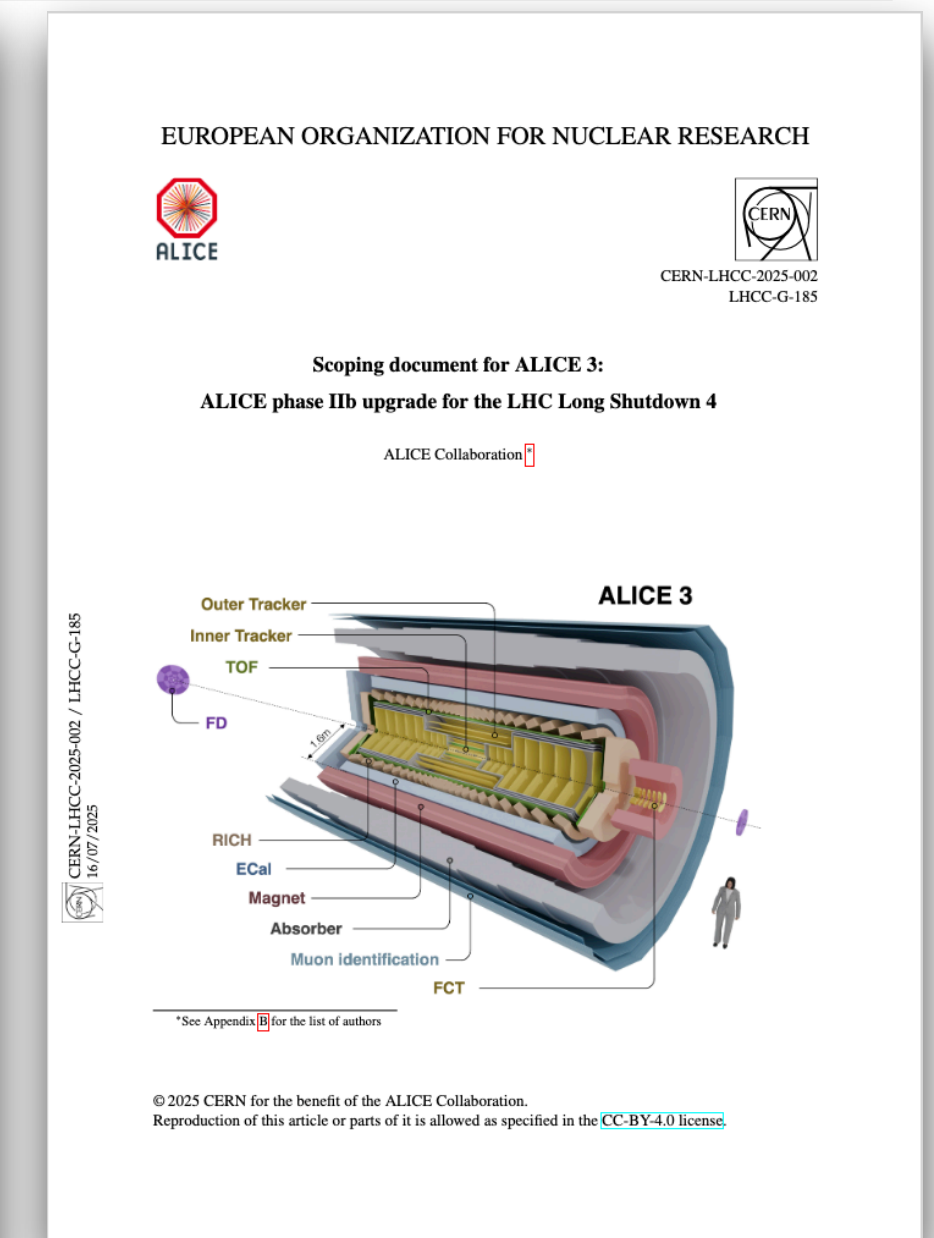
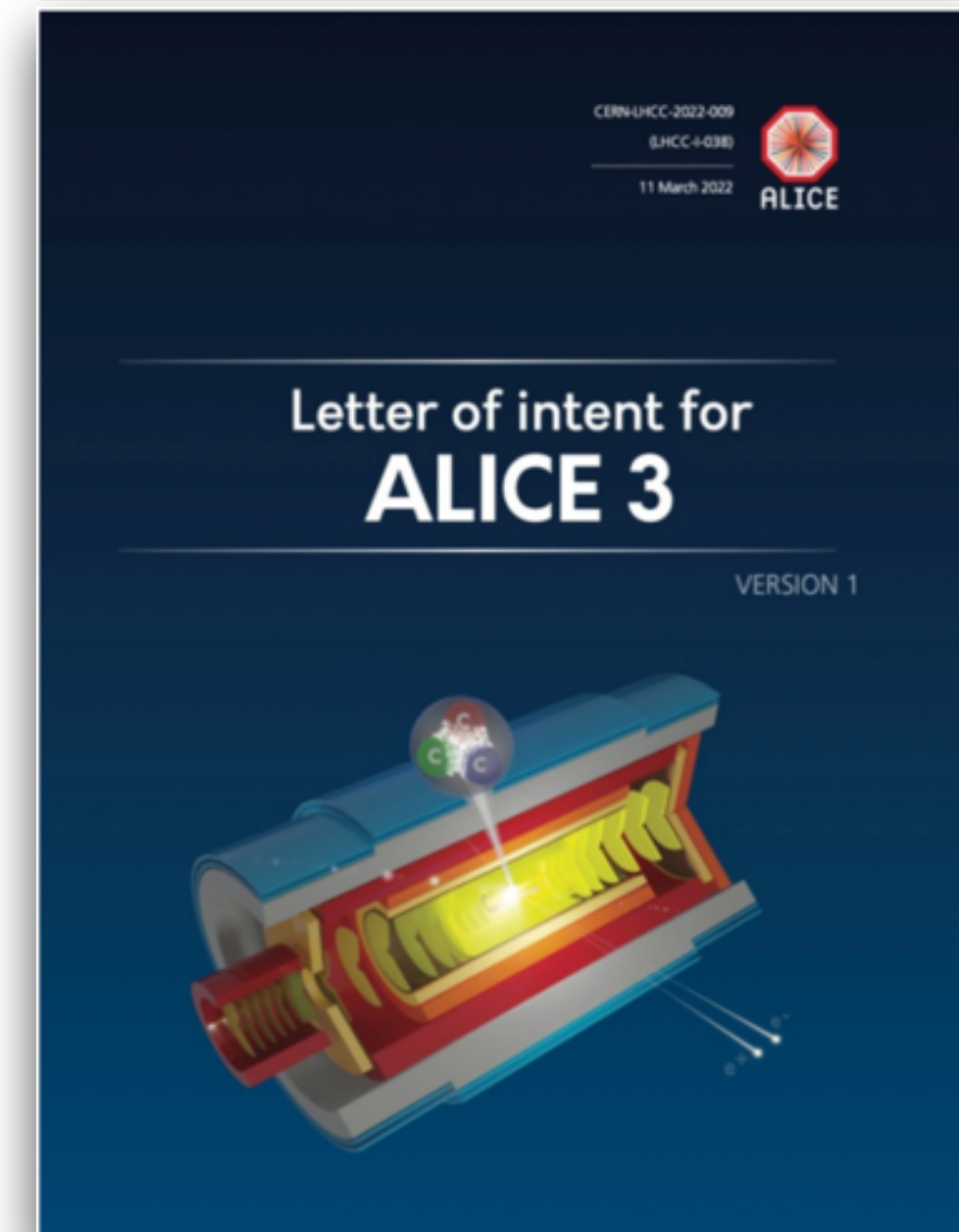

ALICE 3 detector

Novel and innovative detector concept

- Compact and lightweight all-silicon tracker
- Retractable vertex detector
- Particle identification systems
- Large acceptance

ALICE 3 SD: [CERN-LHCC-2025-002](https://cds.cern.ch/record/2811113)
ALICE 3

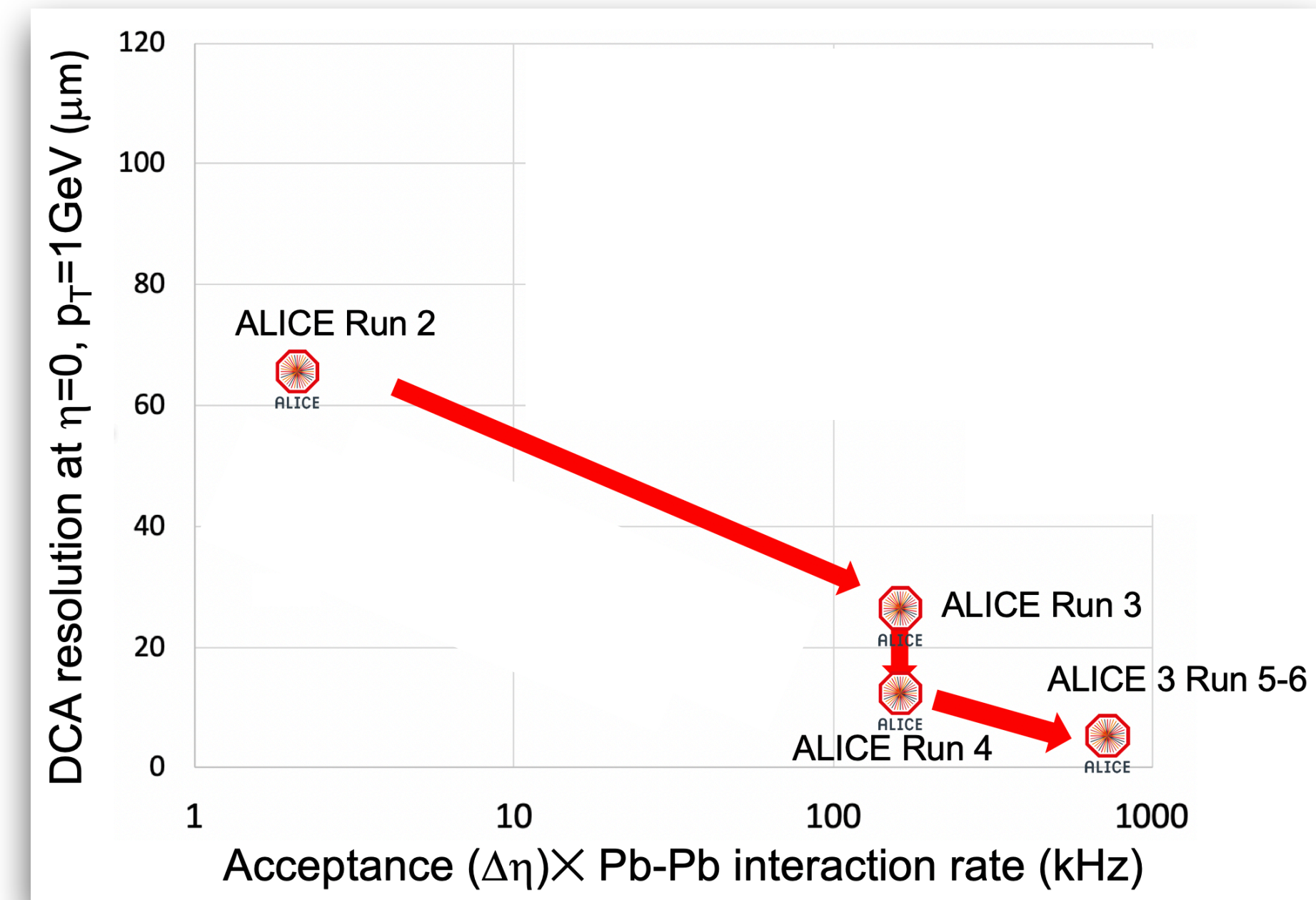
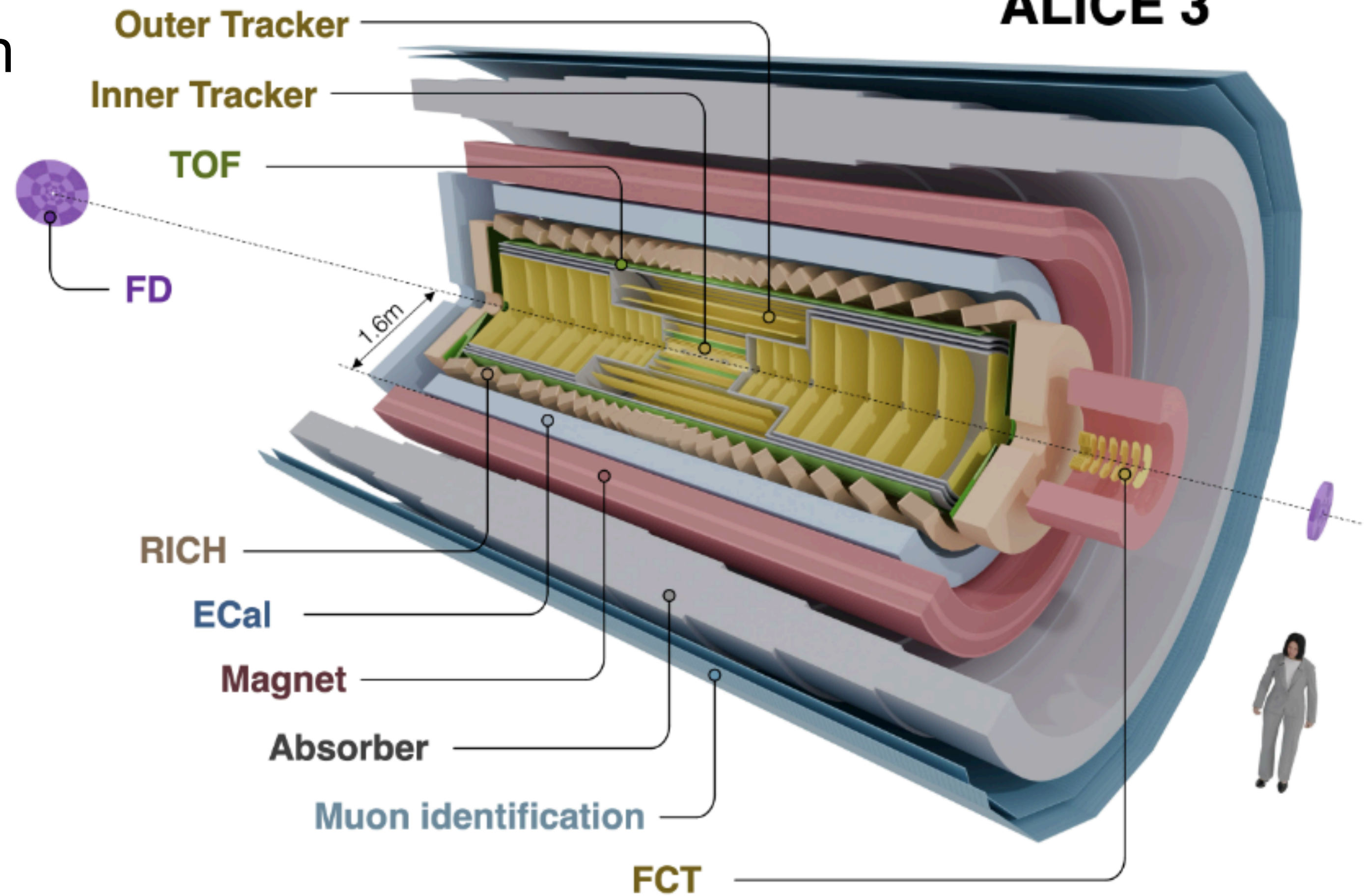

- Superconducting magnet system / Continuous read-out and online processing

ALICE MX in the upgrades for HL-LHC

MID

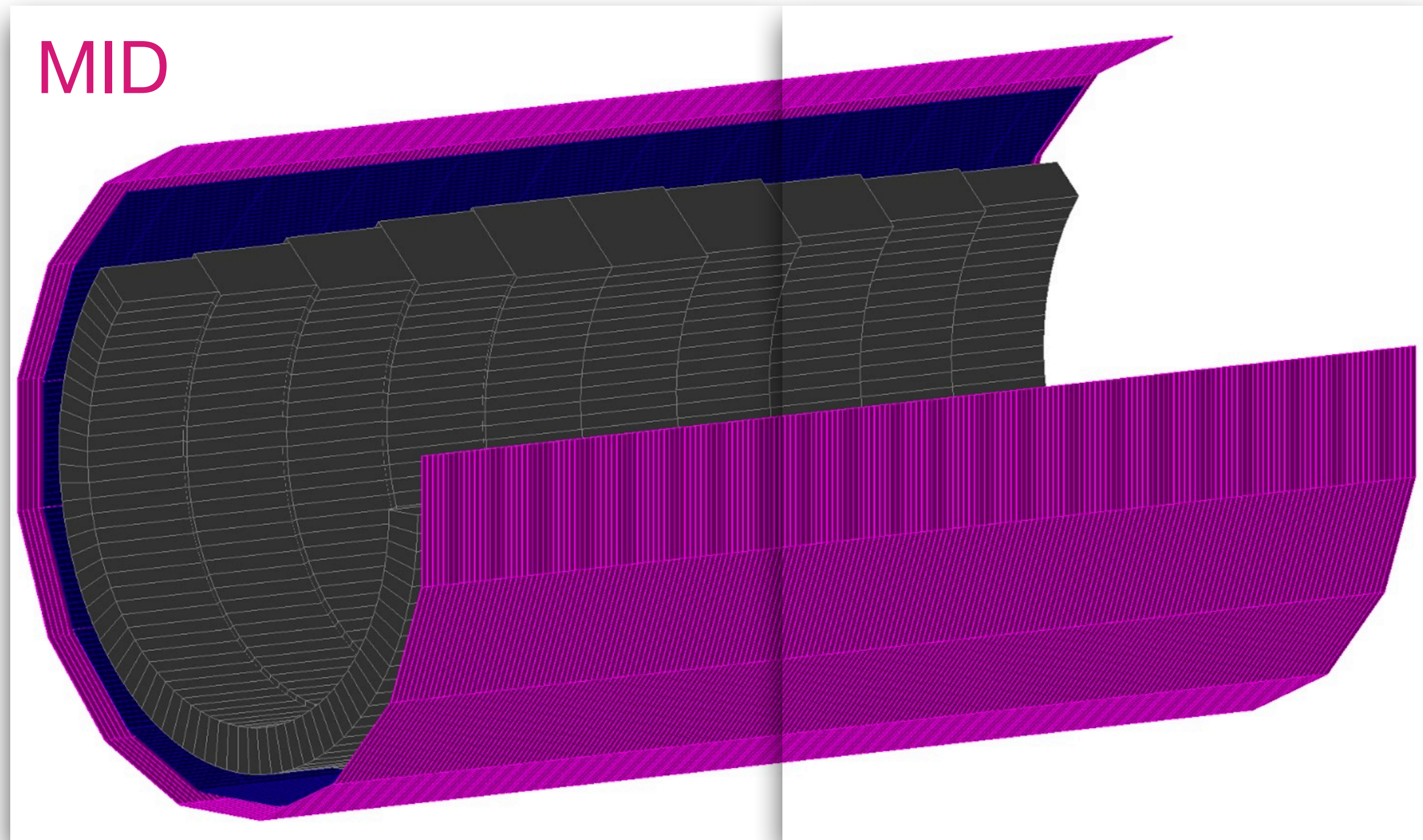

Goal: reconstruct J/ψ from $p_T=0$ in the di-muon decay channel, $p > 1.5$ GeV/c

- Standard magnetic iron absorber, ~ 4 hadronic absorption lengths
- The absorber is followed by MID chambers ($|y| < 1.25$)

Mexican proposal:

- Scintillator-based chambers (each channel: $100 \times 5 \times 1$ cm³ scintillator bar equipped with WLS fiber and readout with SiPM) [baseline option]

	Absorber	MID layer 1	MID layer 2
Inner radius (m)	220	301	311
Outer radius (m)	290	302	312
z range (m)	10	10	10.5
No. sectors in z	9	10	10
No. sectors in ϕ	1	16	16
Scint. bar length (cm)		99.8	123.5
Scint. bar width (cm)		5.0	5.0
Scint. bar thickness (cm)		1.0	1.0

MID: test beam 2023

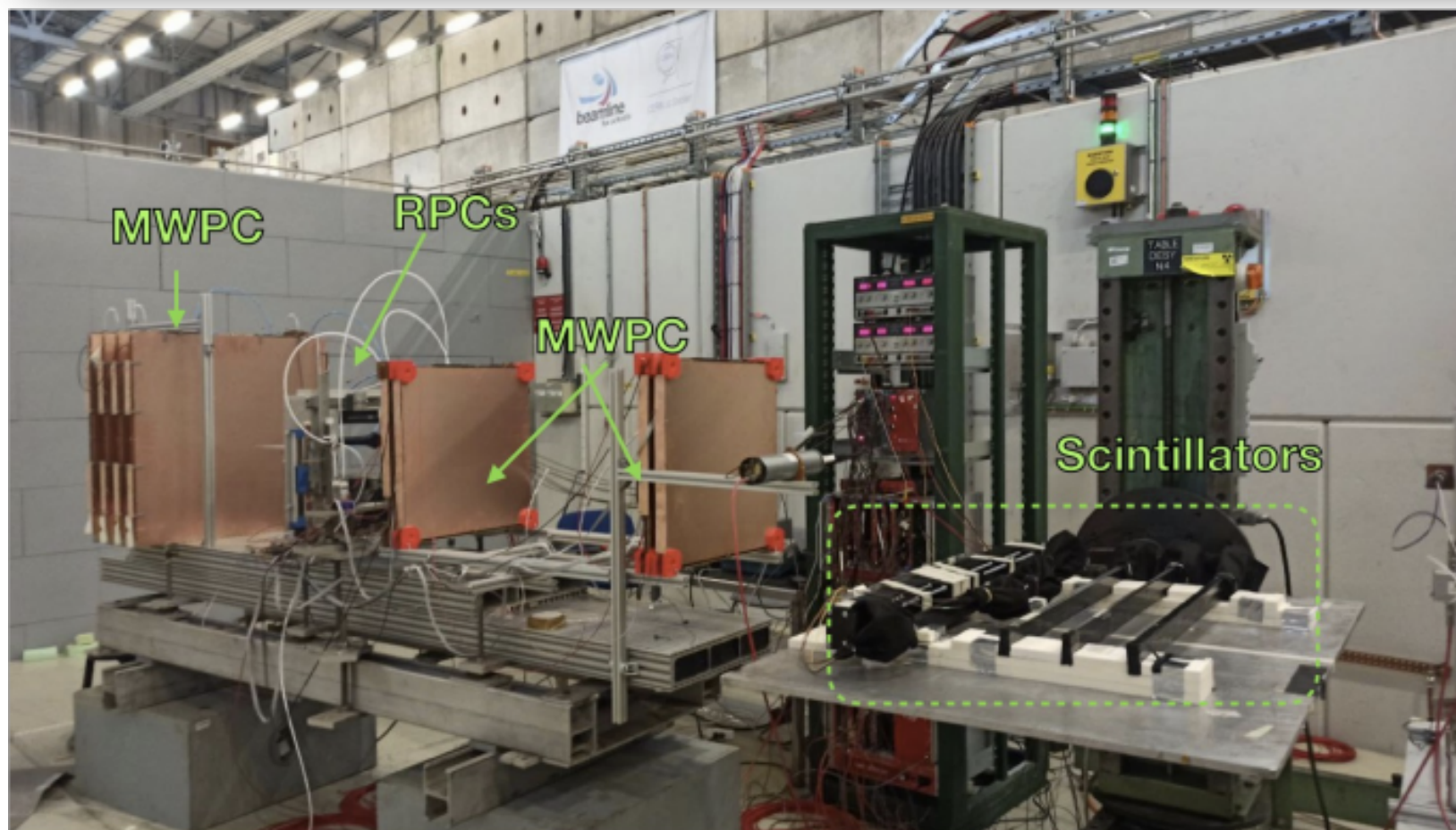
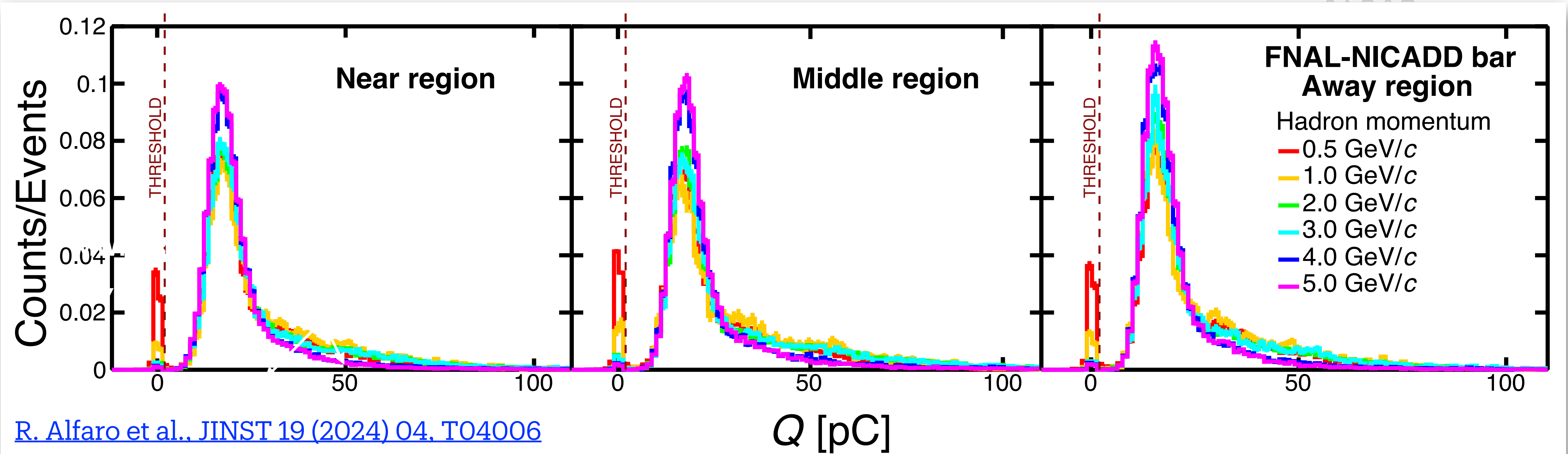

- Low-cost plastic scintillator equipped with WLS fiber: high and uniform efficiency along the bar (1 m length)
- Excellent separation between signal and pedestal. About 40 p.e. are measured for MIP (insensitive to dark count rate)

MID: test beam 2024



J. E. Muñoz et al., JINST 20 (2025) 09, P09015

PAPER • OPEN ACCESS

ML-based muon identification using a FNAL-NICADD scintillator chamber for the MID subsystem of ALICE 3

Jesús Eduardo Muñoz Méndez, Antonio Ortiz, Antonio Paz, Paola Vargas Torres, Ruben Alfaro Molina, Laura Helena González Trueba, Varlen Grabski, Arturo Fernández Téllez, Hector David Regules Medel, Mario Rodríguez Cahuantzi, Guillermo Tejeda Muñoz, Yael Antonio Vásquez Beltran, Juan Carlos Cabanillas Noris, Solangel Rojas Torres, Gergely Gábor Barnaföldi, Dániel Száraz, Dezső Varga, Róbert Vértesi and Edmundo García Solís

Published 10 September 2025 • © 2025 The Author(s)

Journal of Instrumentation, Volume 20, September 2025

Citation Jesús Eduardo Muñoz Méndez et al 2025 JINST 20 P09015

DOI 10.1088/1748-0221/20/09/P09015

Antonio Ortiz (MWPF 2025, León, Guanajuato, Mexico)



All hits

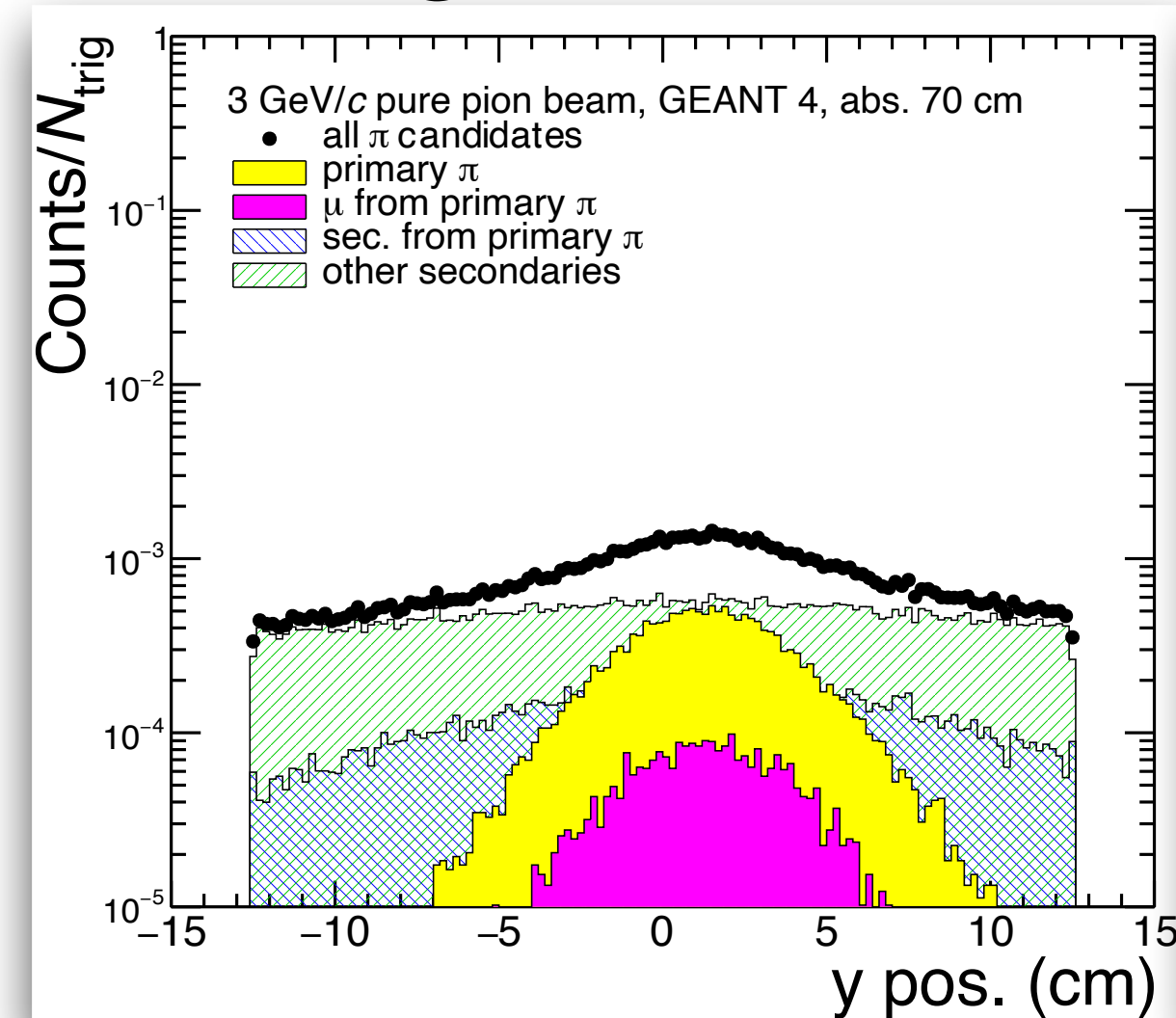

Time selection

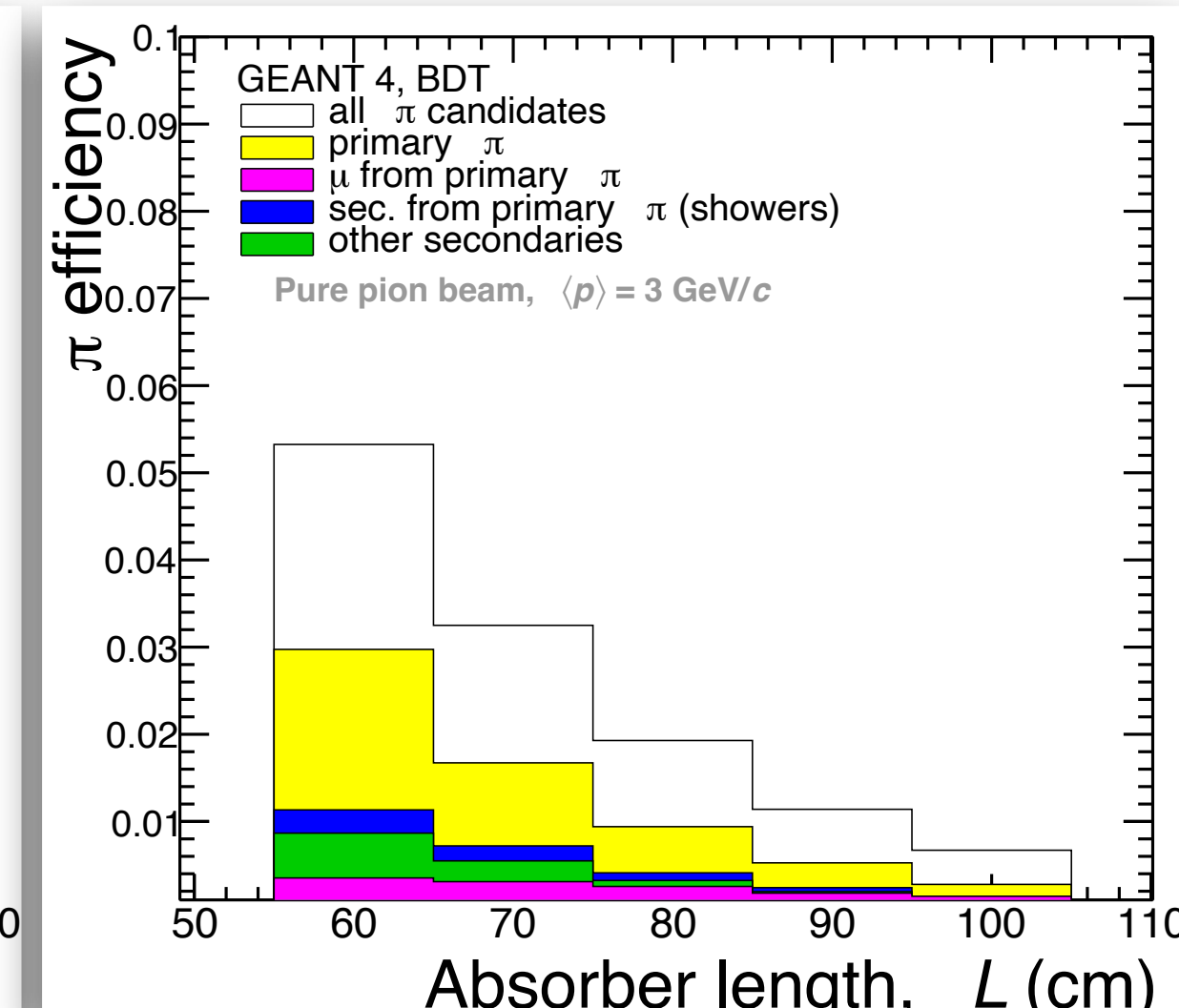
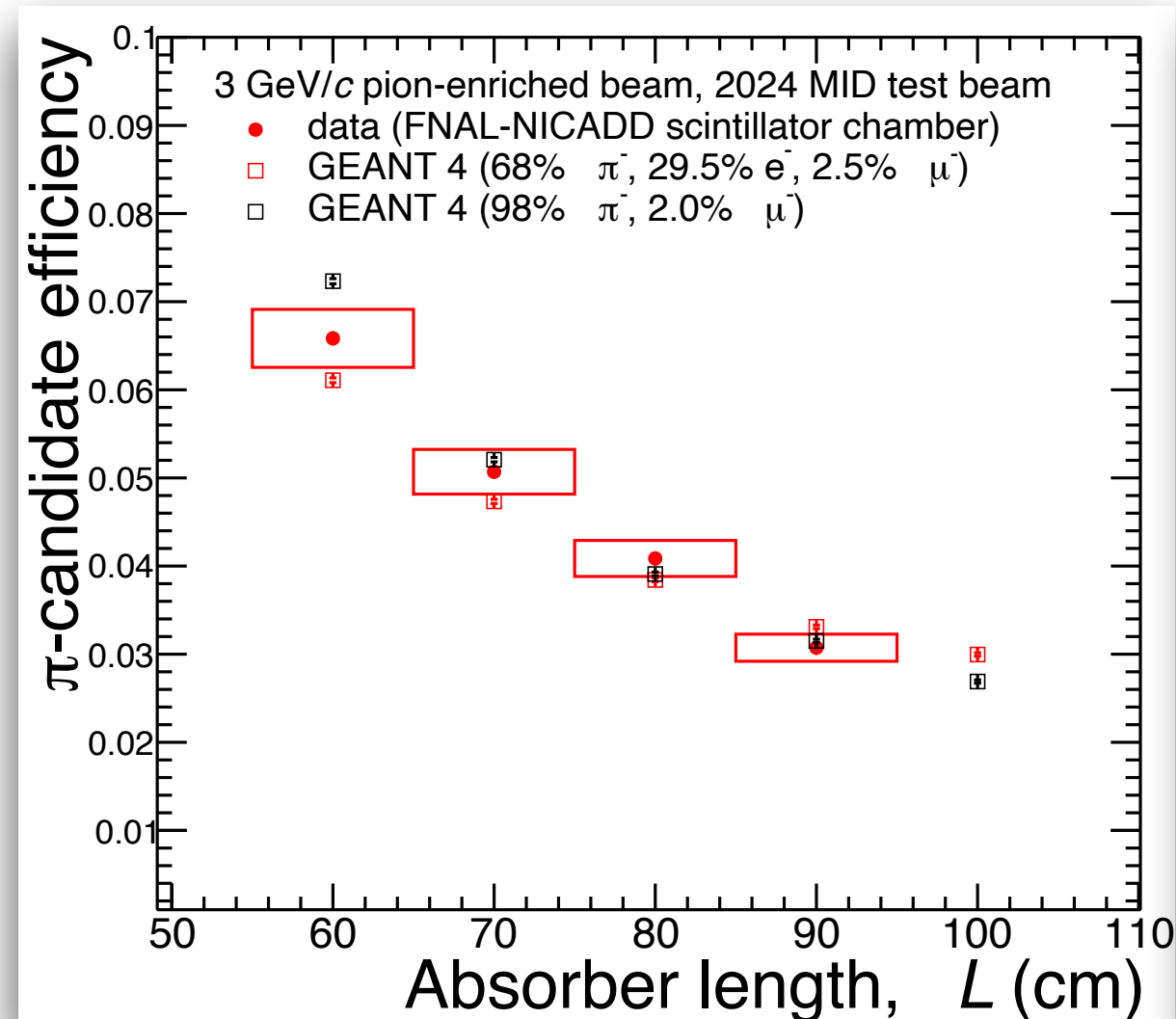
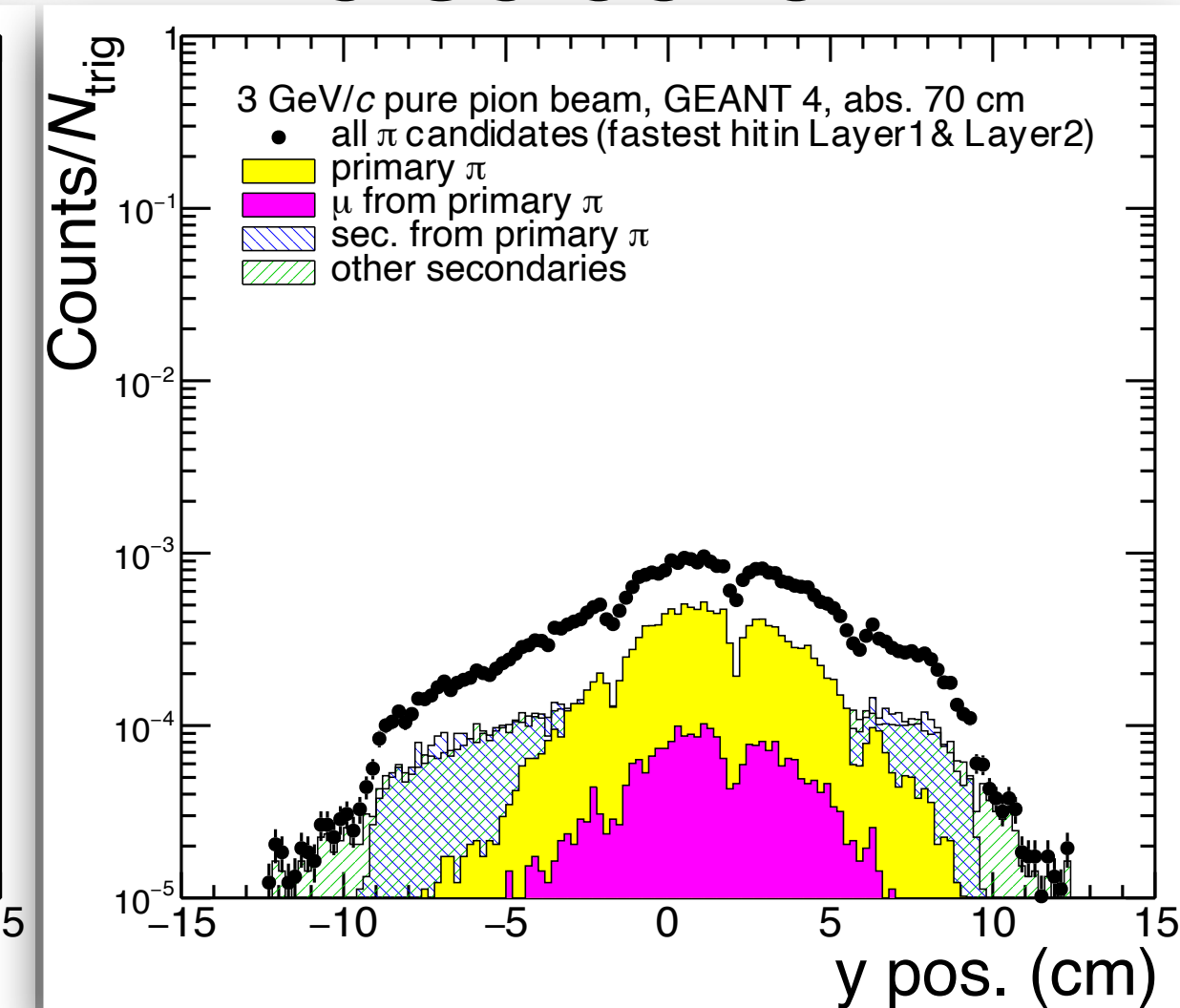

MID: test beam 2025

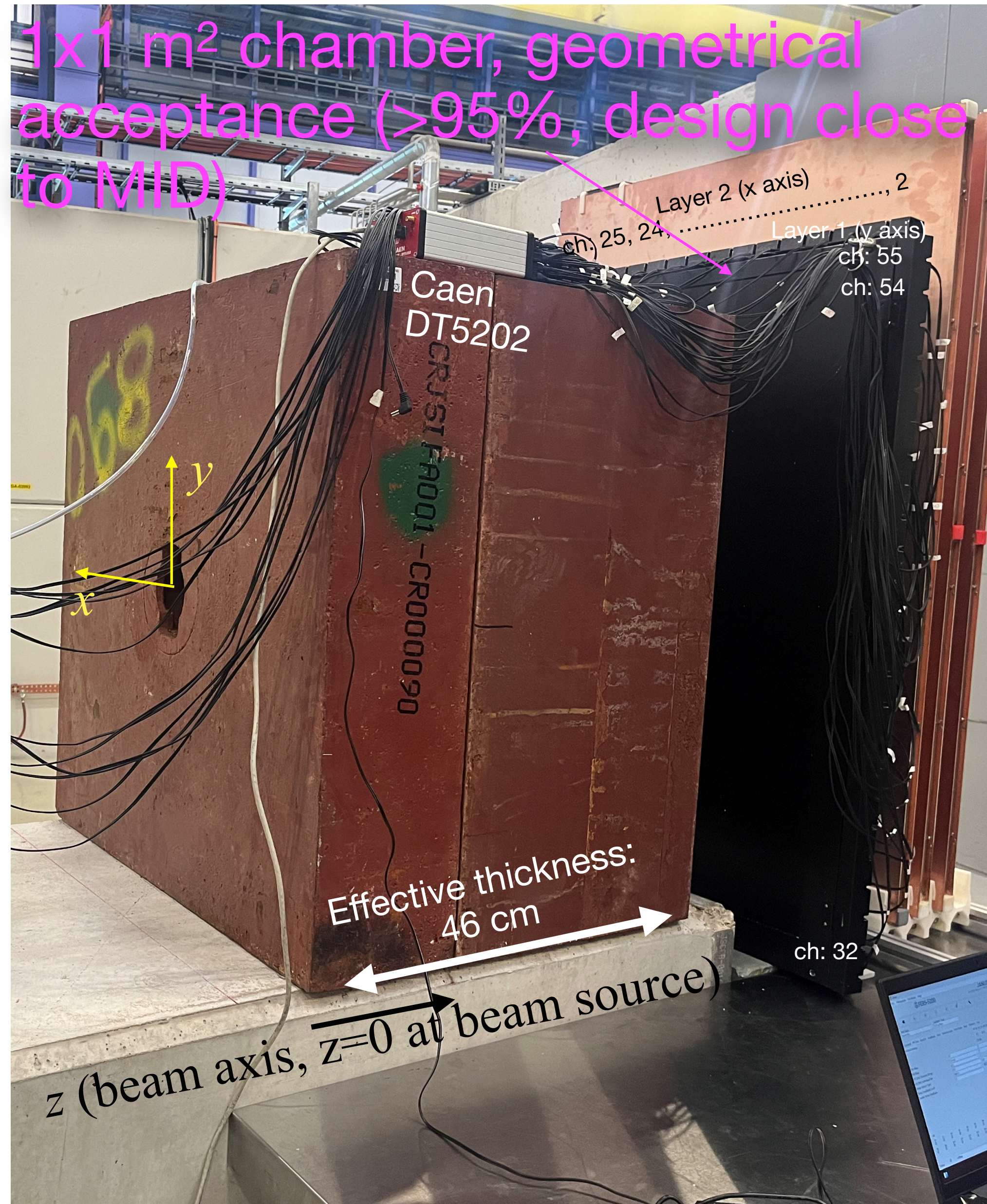

- 48 channels (<1mm bar spacing): FNAL scintillator bar + Kuraray WLS fiber + SiPMs (S14160-3050HS). Data acquisition: caen DT5202
- Version 1 of FEC was tested

AccXEff above 98% (ML)

Fraction of acc. hadrons ~2.8% (70 cm absorber)

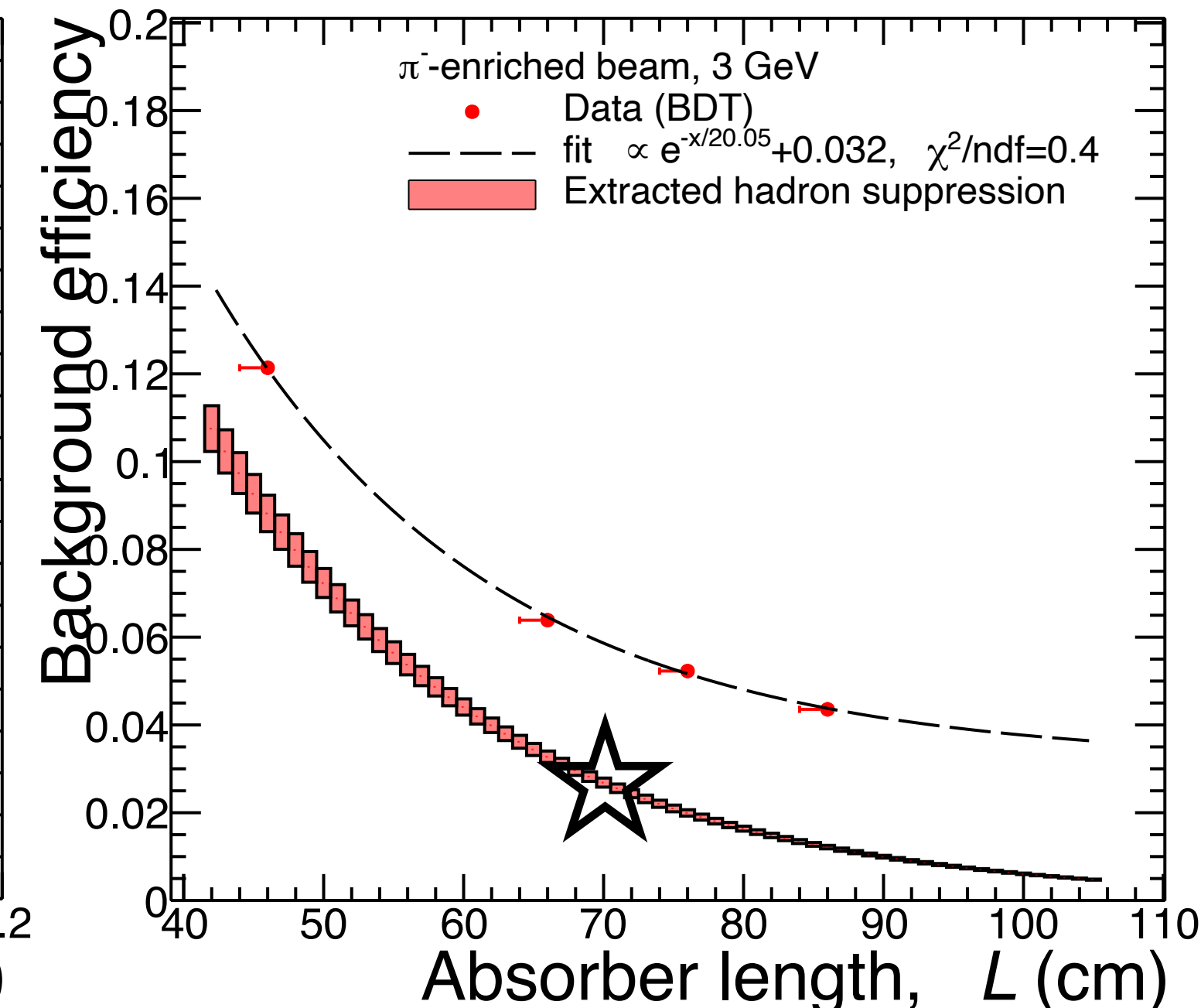
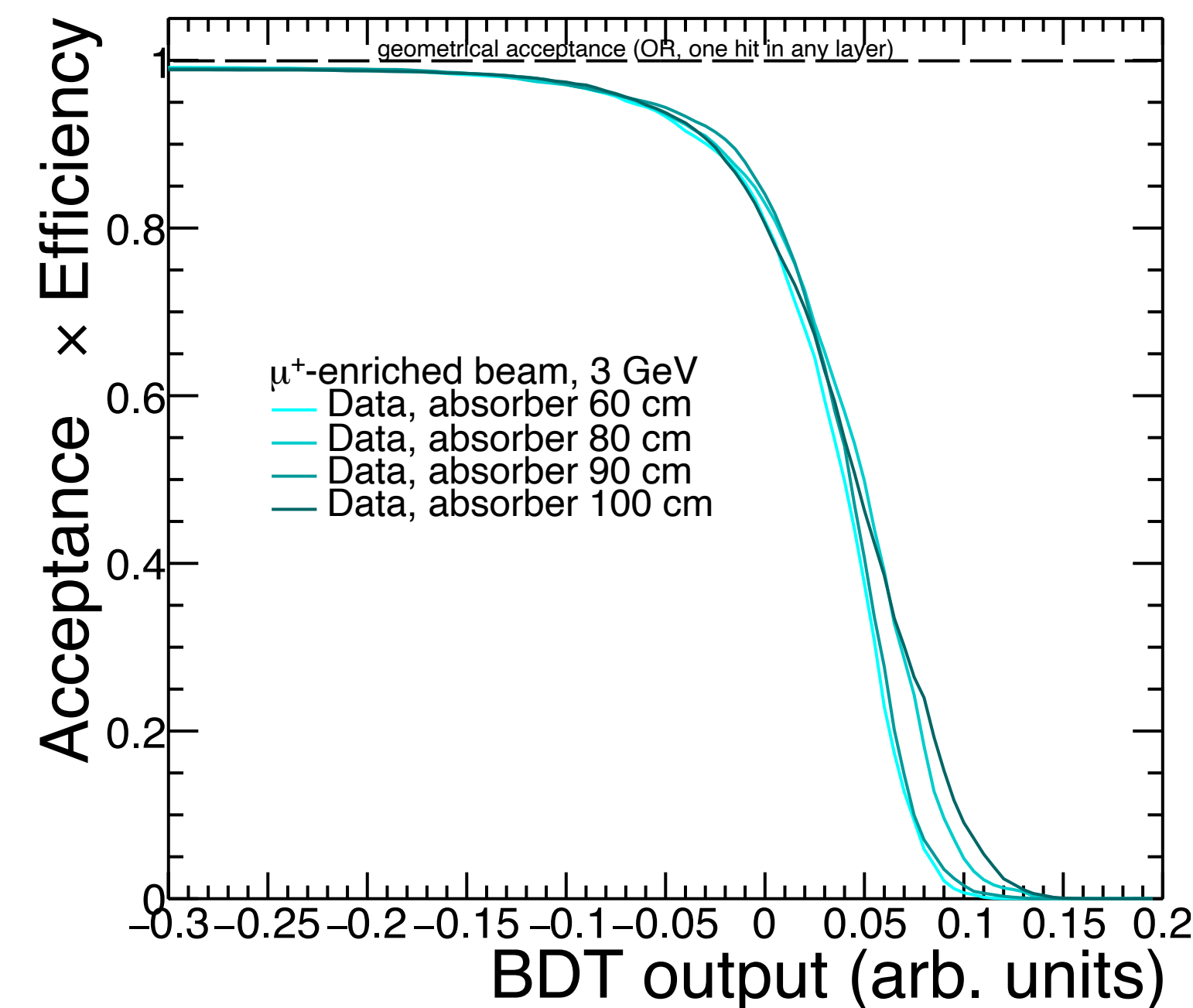

Summary

Run 3 is well underway

ALICE 2 is fully commissioned: new analysis with LHC Run 3 data

Fundamental advances in QGP and QCD physics

Further developments pursued simultaneously

TDR: ITS3, FoCal in LS3

ALICE 3: the ultimate high-density QCD experiment

MID Mexican proposal is going well



Thank you!

Backup



Transmutation (theory)

- Accelerator configured for a certain beam rigidity
 - Ions with the same A/Z ratio have the same rigidity
 - ^{16}O and ^{20}Ne are on $A = 2Z$
- Hadronic and e.m. interactions lead to ^{16}O , ^{14}N , ^{12}C , ^{10}B , ^8Be , ^6Li , ^4He , d (all except Be stable)
 - What happens in the beam, stays in the beam...
- Main contamination (from simulation): He-O and O-He collisions
- Experimental assessment of these contaminations crucial

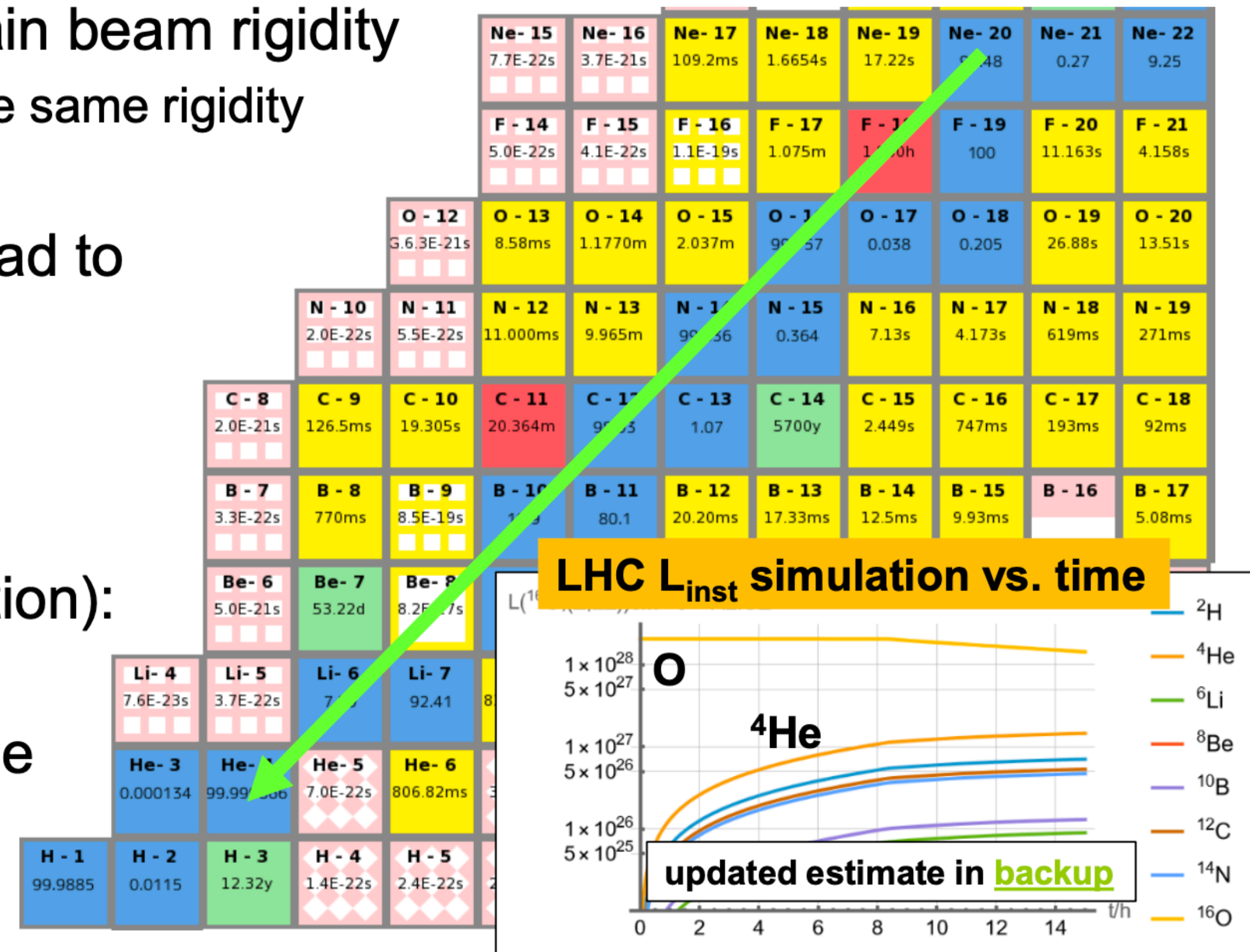

Goal: determine small-x gluon density in the nucleus by measuring forward production of isolated direct photons, π^0 , jets

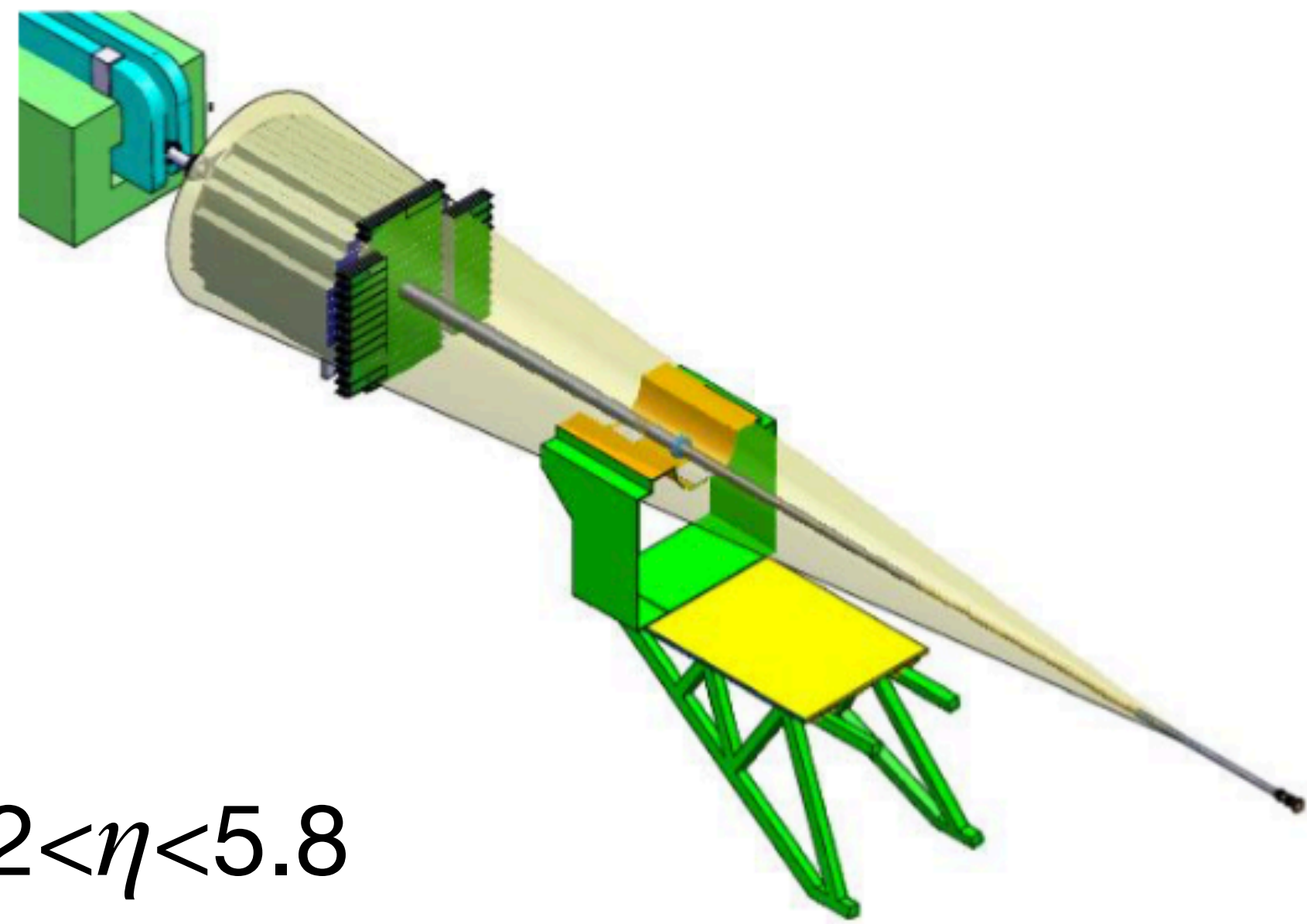

$3.2 < \eta < 5.8$

Highly granular Si+W electromagnetic calorimeter (FoCal-E)

Cu+scintillating-fiber hadronic calorimeter (FoCal-H)

Final prototype of FoCal (tested at SPS)

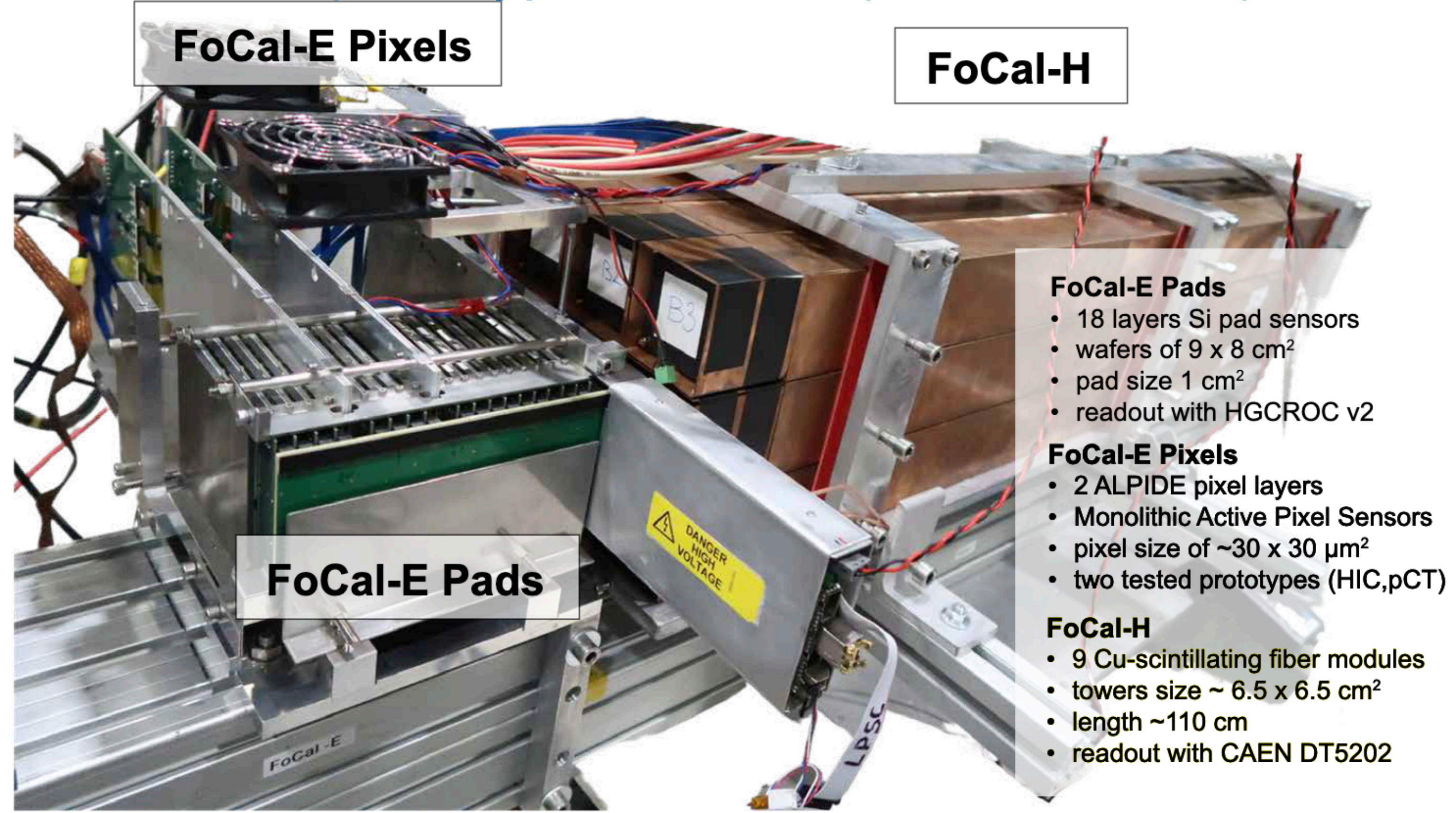

- FoCal-E Pads**
 - 18 layers Si pad sensors
 - wafers of 9 x 8 cm²
 - pad size 1 cm²
 - readout with HGCROC v2
- FoCal-E Pixels**
 - 2 ALPIDE pixel layers
 - Monolithic Active Pixel Sensors
 - pixel size of ~30 x 30 μm^2
 - two tested prototypes (HIC,pCT)
- FoCal-H**
 - 9 Cu-scintillating fiber modules
 - towers size ~ 6.5 x 6.5 cm²
 - length ~110 cm
 - readout with CAEN DT5202

TDR approved [CERN-LHCC-2024-004, ALICE-TDR-022](https://cds.cern.ch/record/2814441/files/CERN-LHCC-2024-004_ALICE-TDR-022.pdf)

ITS3: replace the 3 inner-most vertexing layers of ALICE with ultra-light tracking layers (0.07% X_0 per layer)

Improved pointing resolution for heavy flavour reconstruction

Di-lepton measurements

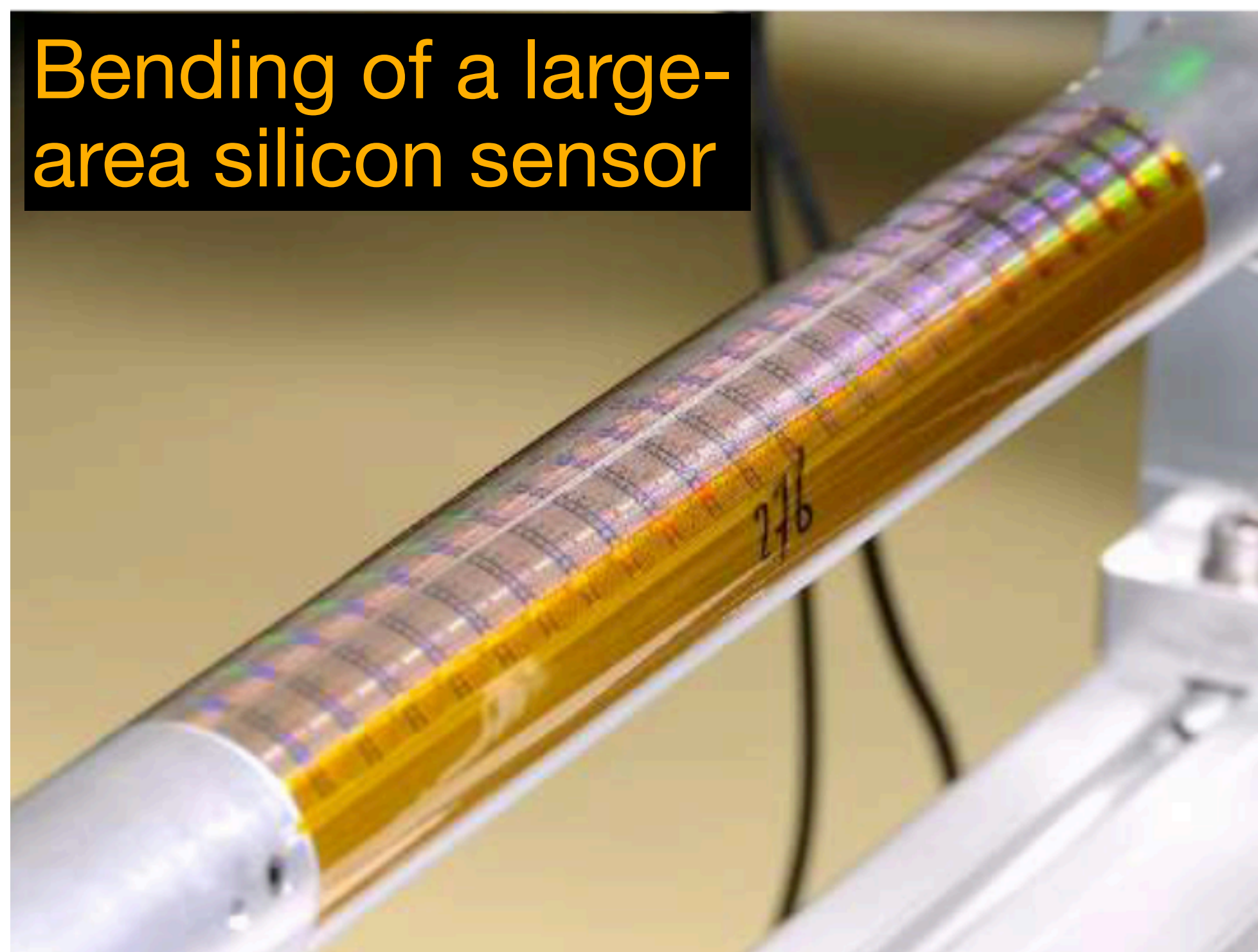
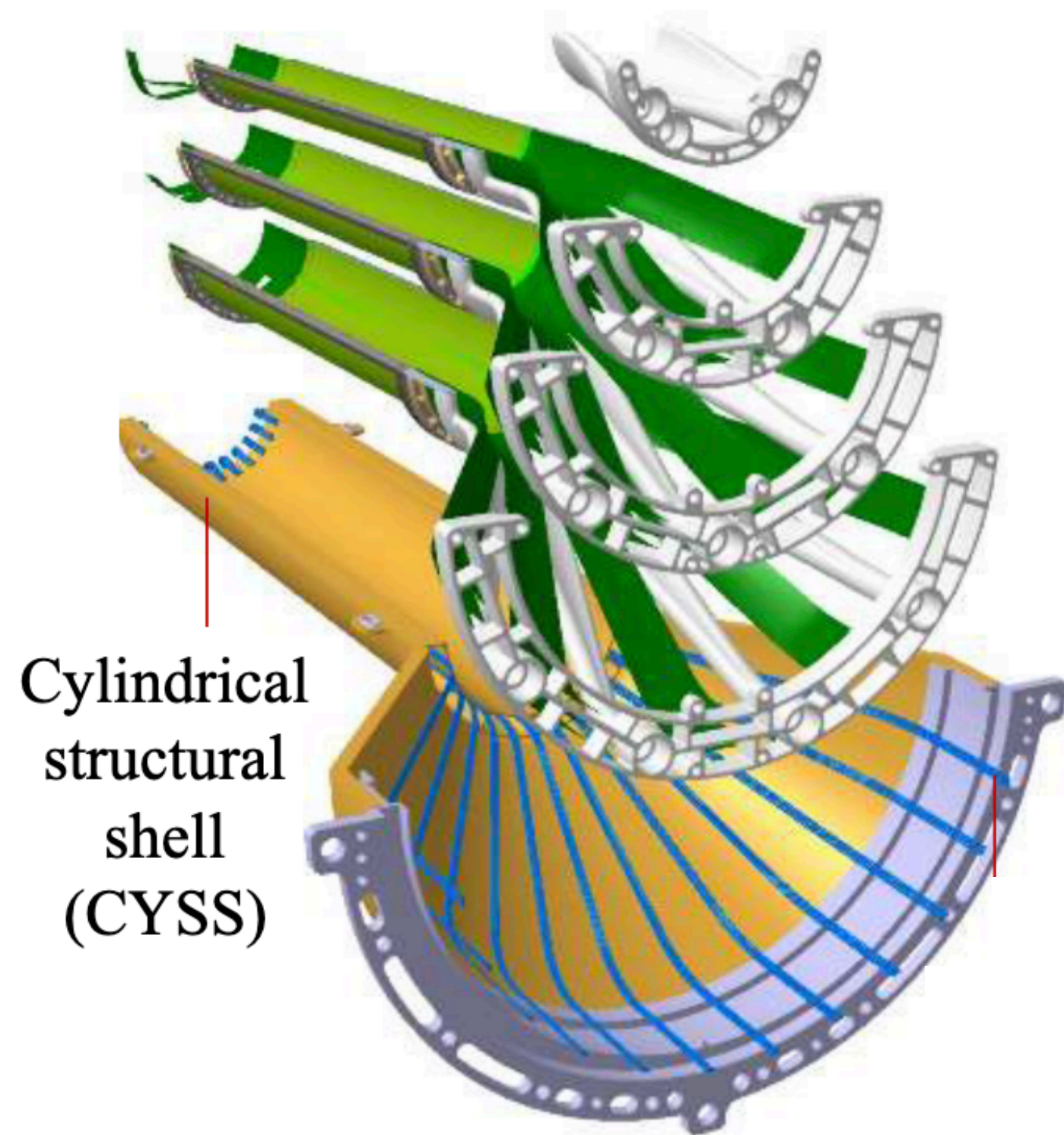

Digital pixel test structure

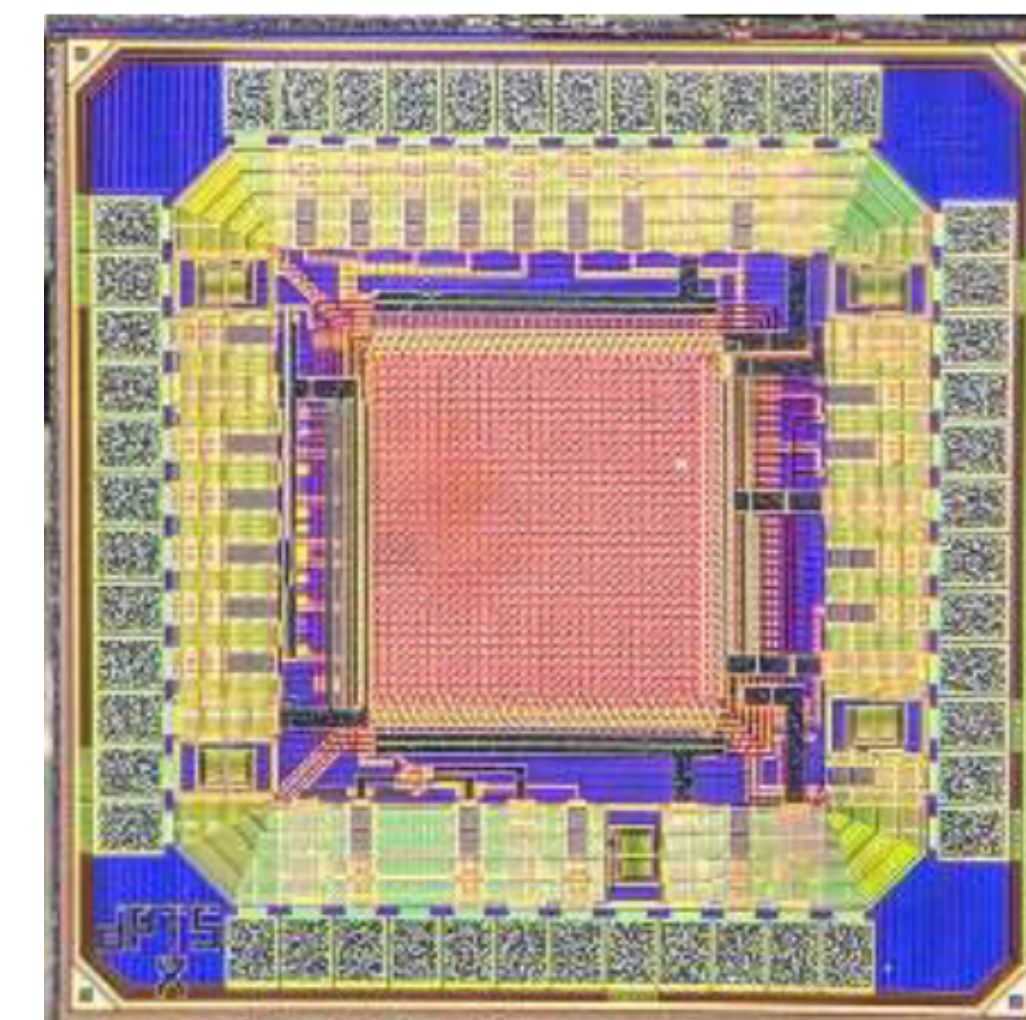

TDR approved [CERN-LHCC-2024-003](https://cds.cern.ch/record/2811113/files/CERN-LHCC-2024-003) ; [ALICE-TDR-021](https://cds.cern.ch/record/2811113/files/ALICE-TDR-021)

Questions to be addressed in Runs 3 & 4

Runs 3 and 4

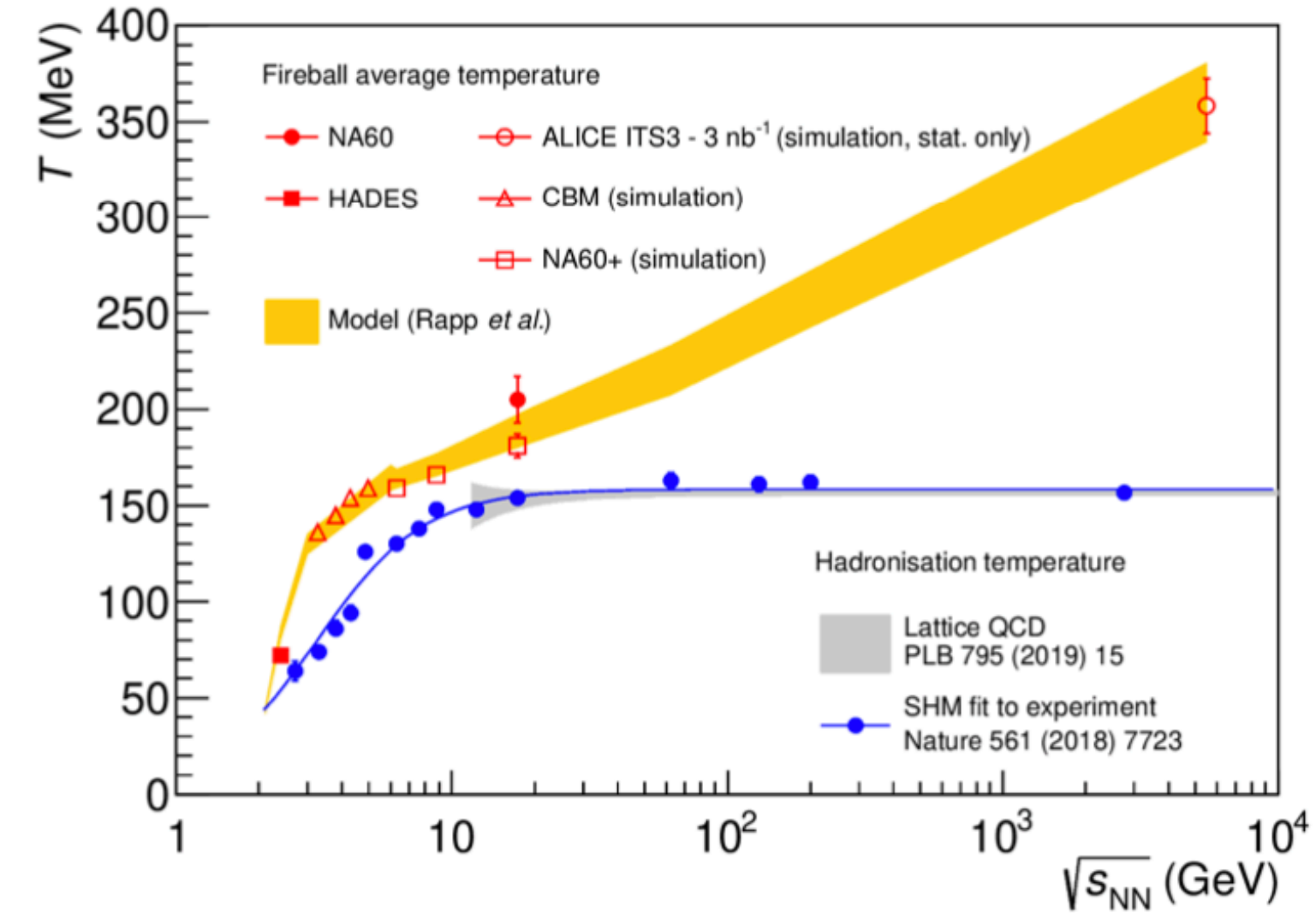

Time-averaged thermal radiation from QGP

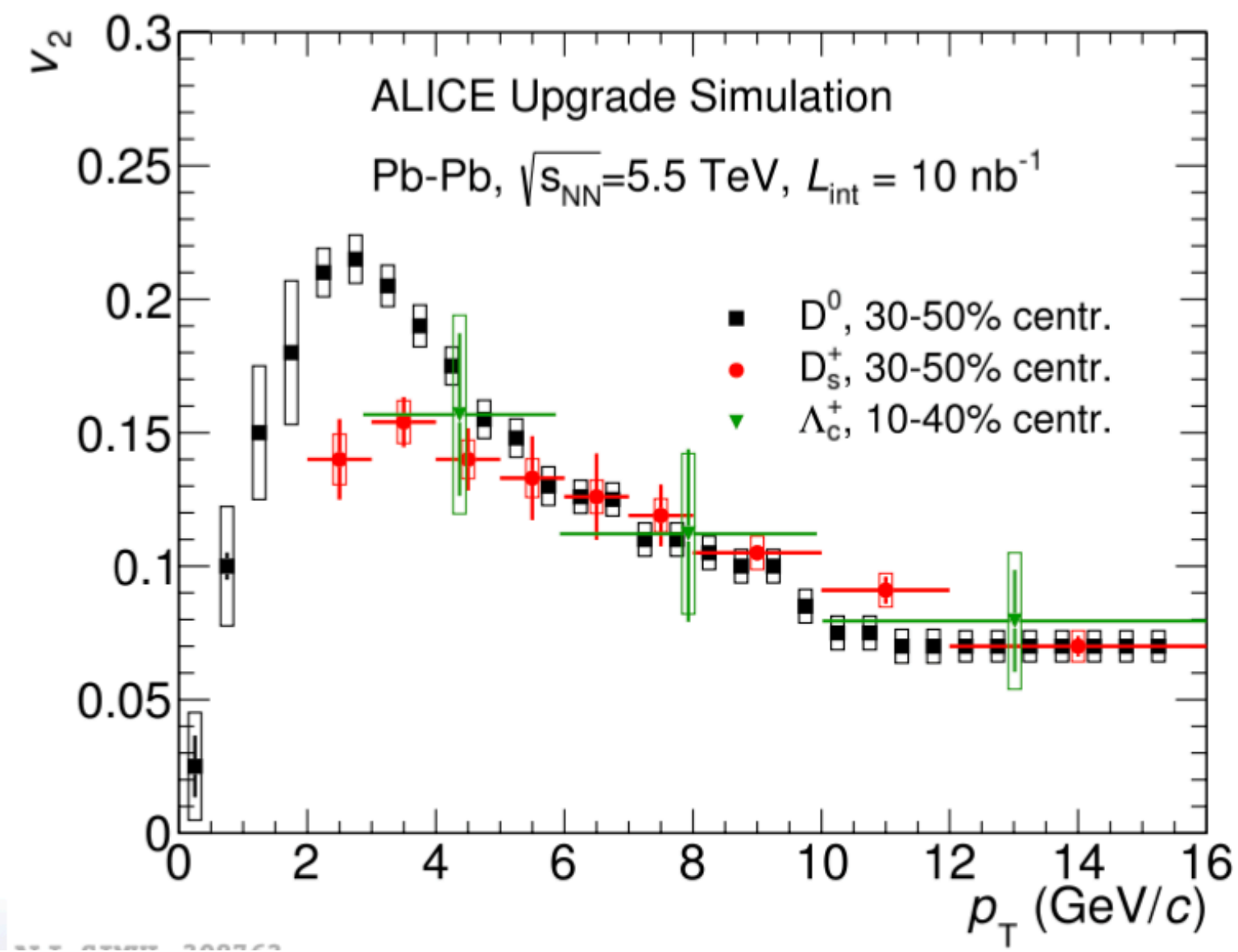

Medium effects and hadrochemistry of single charm

- What is the nature of interactions between highly energetic quarks and gluons and the quark-gluon plasma?
- To what extent do quarks of different mass reach thermal equilibrium?
- How do quarks and gluons transition to hadrons as the quark-gluon plasma cools down?
- What are the mechanisms for the restoration of chiral symmetry in the quark-gluon plasma?

Run-3 physics performance

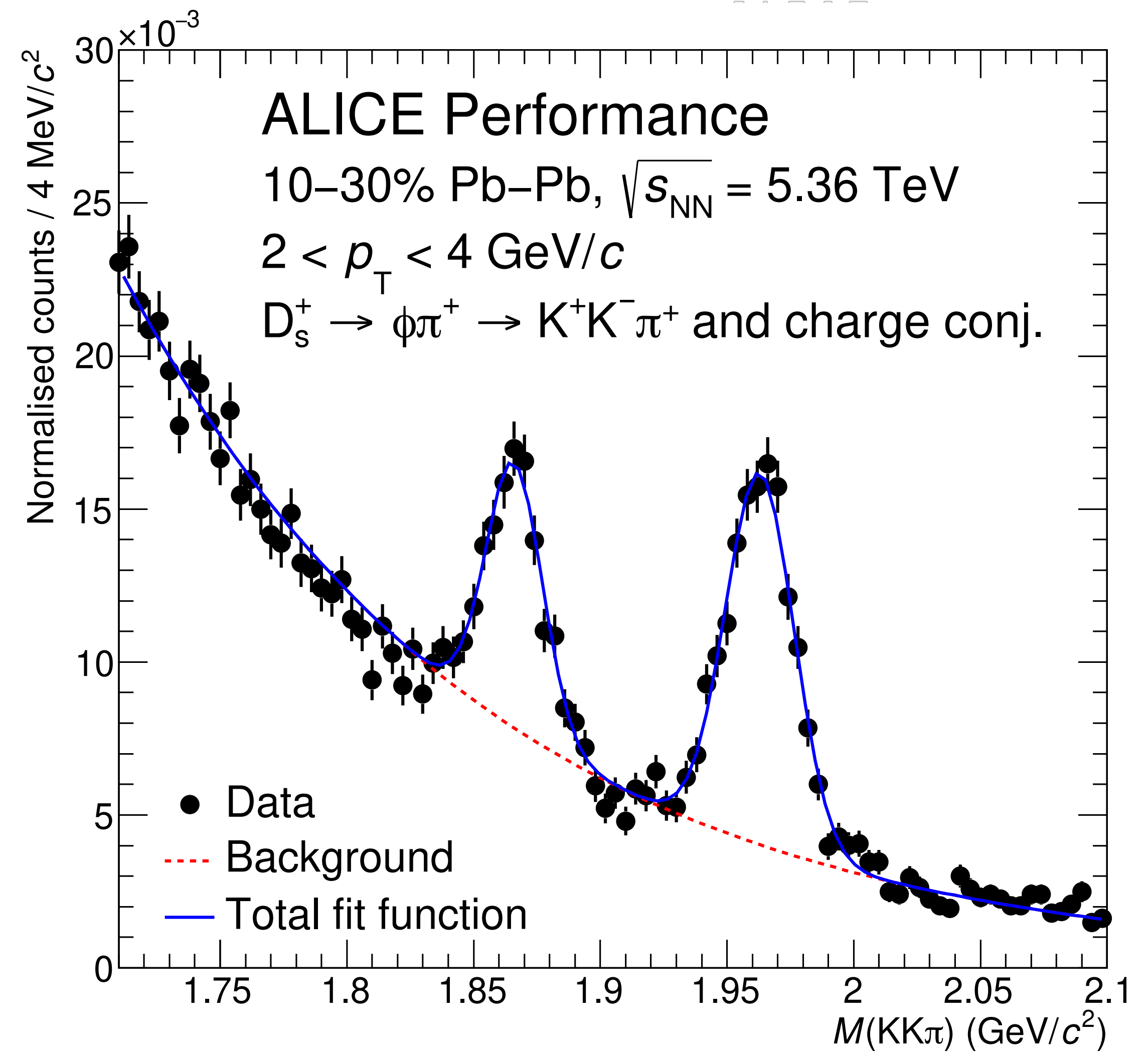
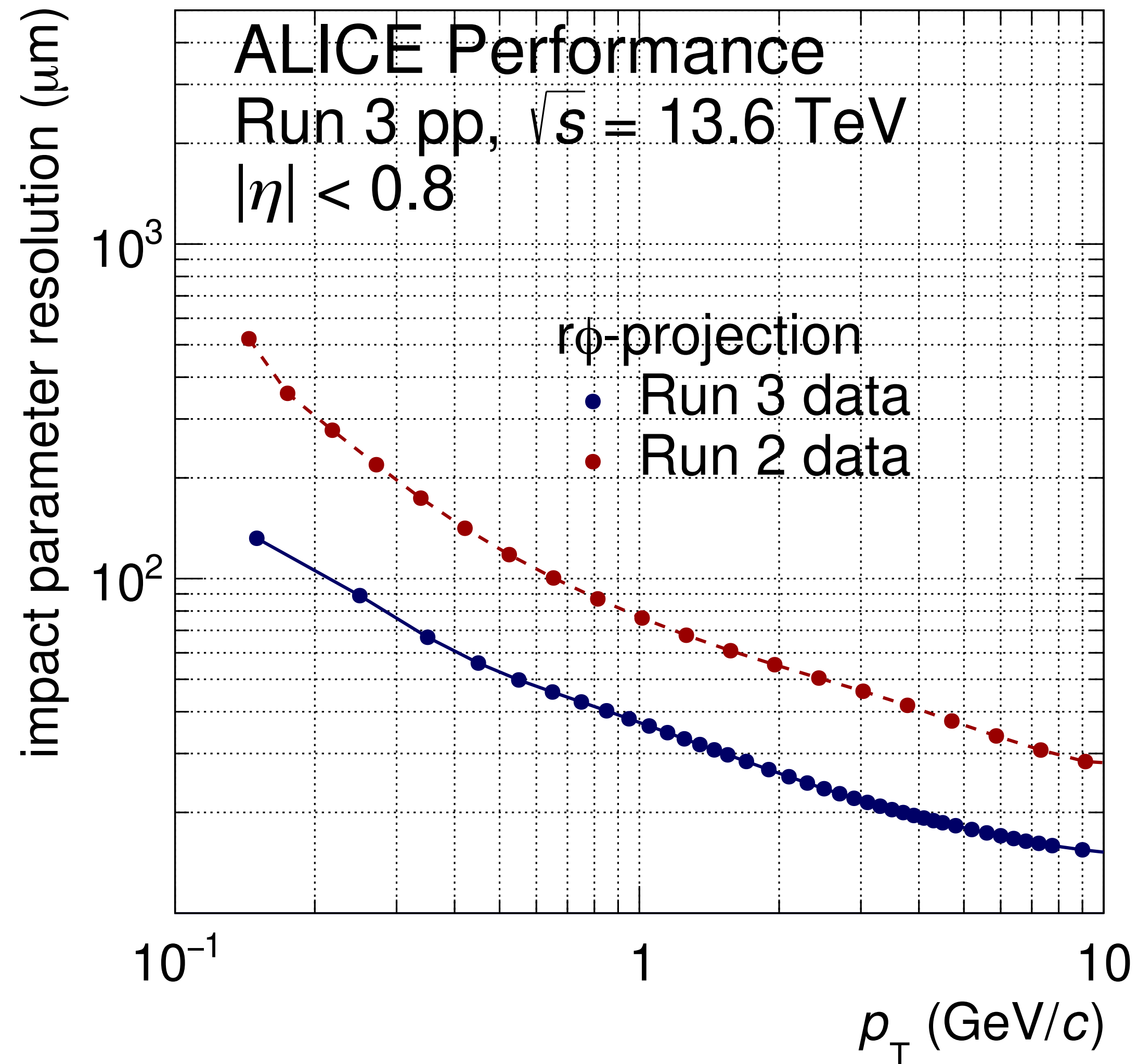

ALI-PERF-558822

ALI-PERF-568632

LS2 upgrades: improved pointing resolution and larger data samples

Time evolution & chiral symmetry

Understand time evolution and mechanisms of chiral symmetry restoration:

- high-precision measurements of dileptons, also multi-differentially
- further reduced material; excellent heavy-flavour rejection

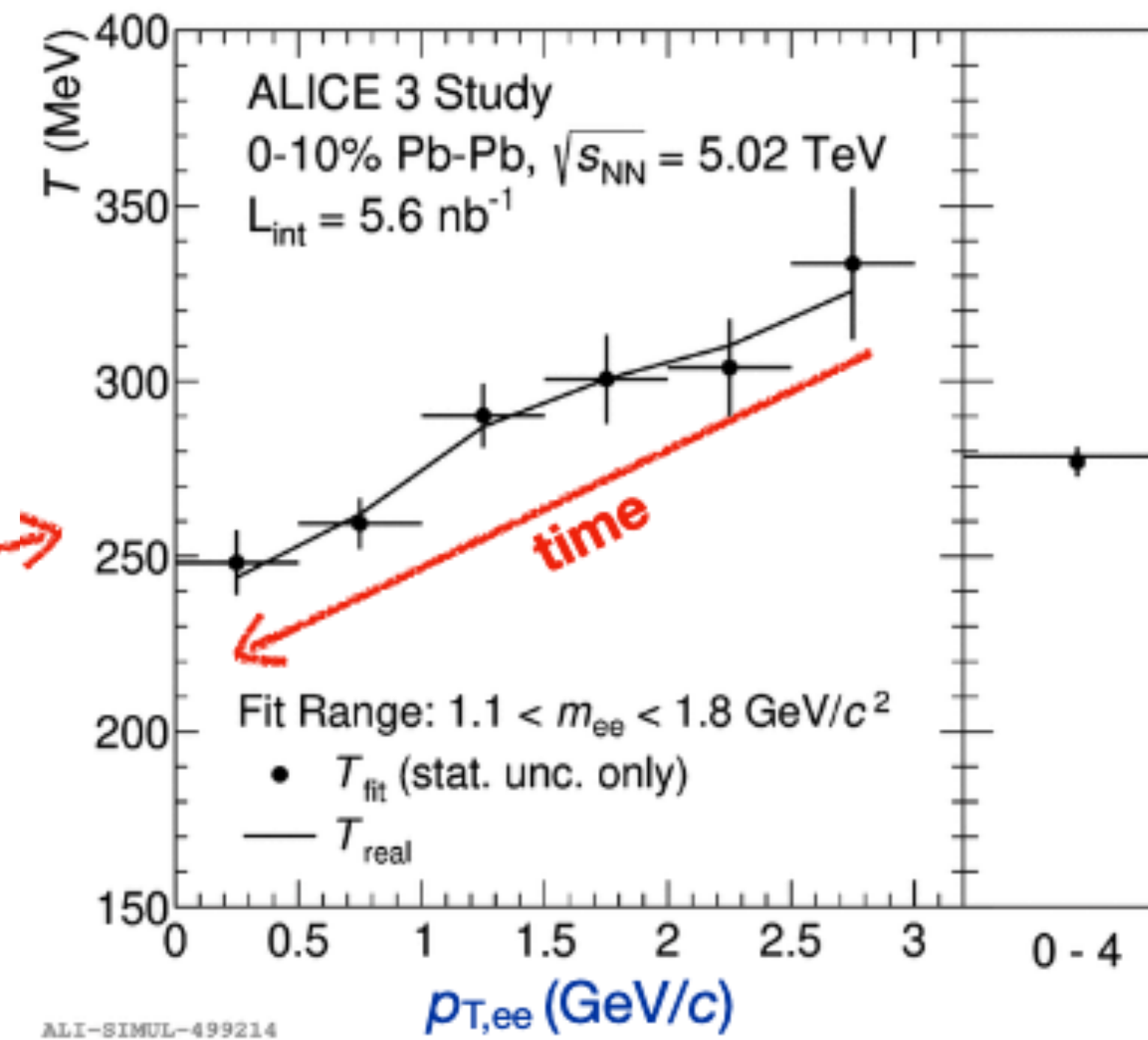
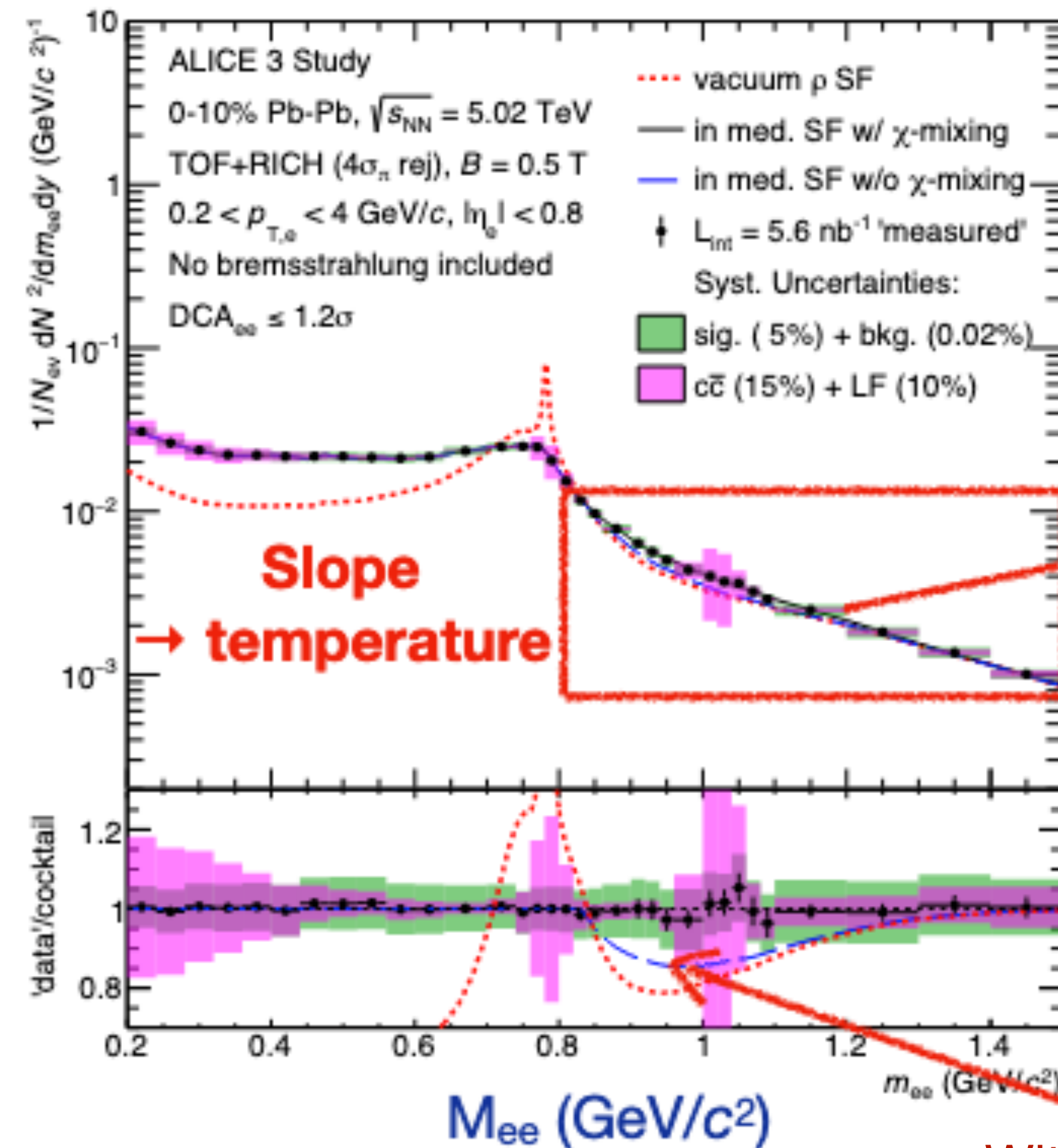
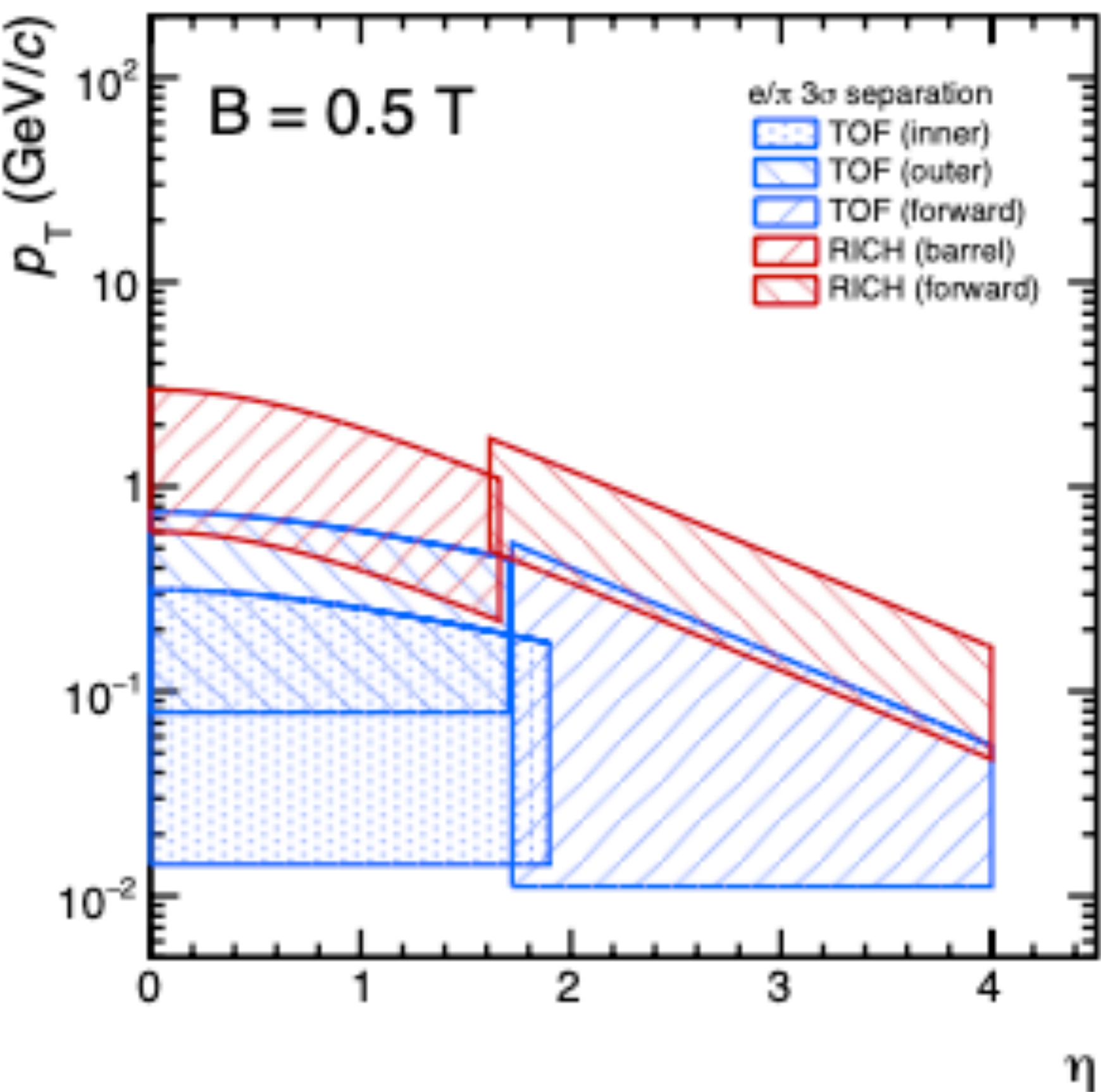

Without ρ -a1 mixing → dip in thermal spectrum

* SF: Spectral Function

Exotic hadrons

$$X(3872) \rightarrow J/\psi + \pi^+ \pi^-$$

X(3872)

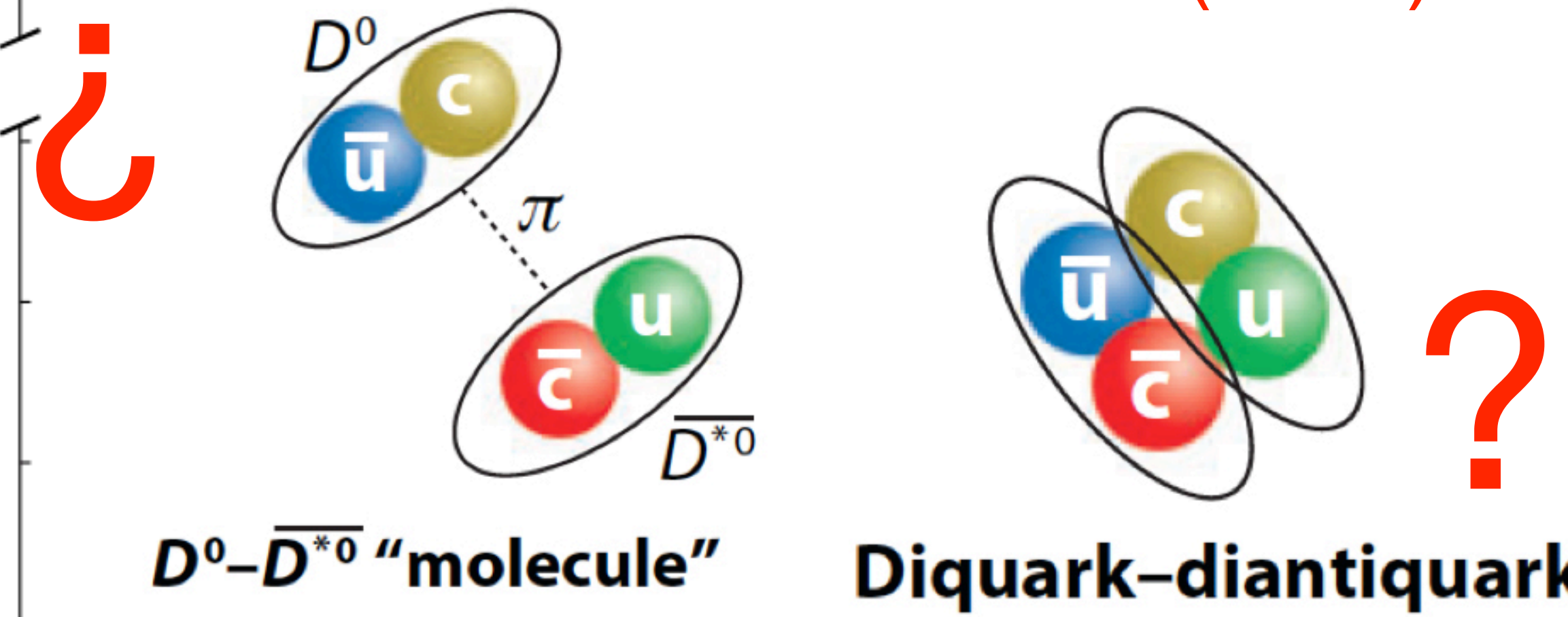
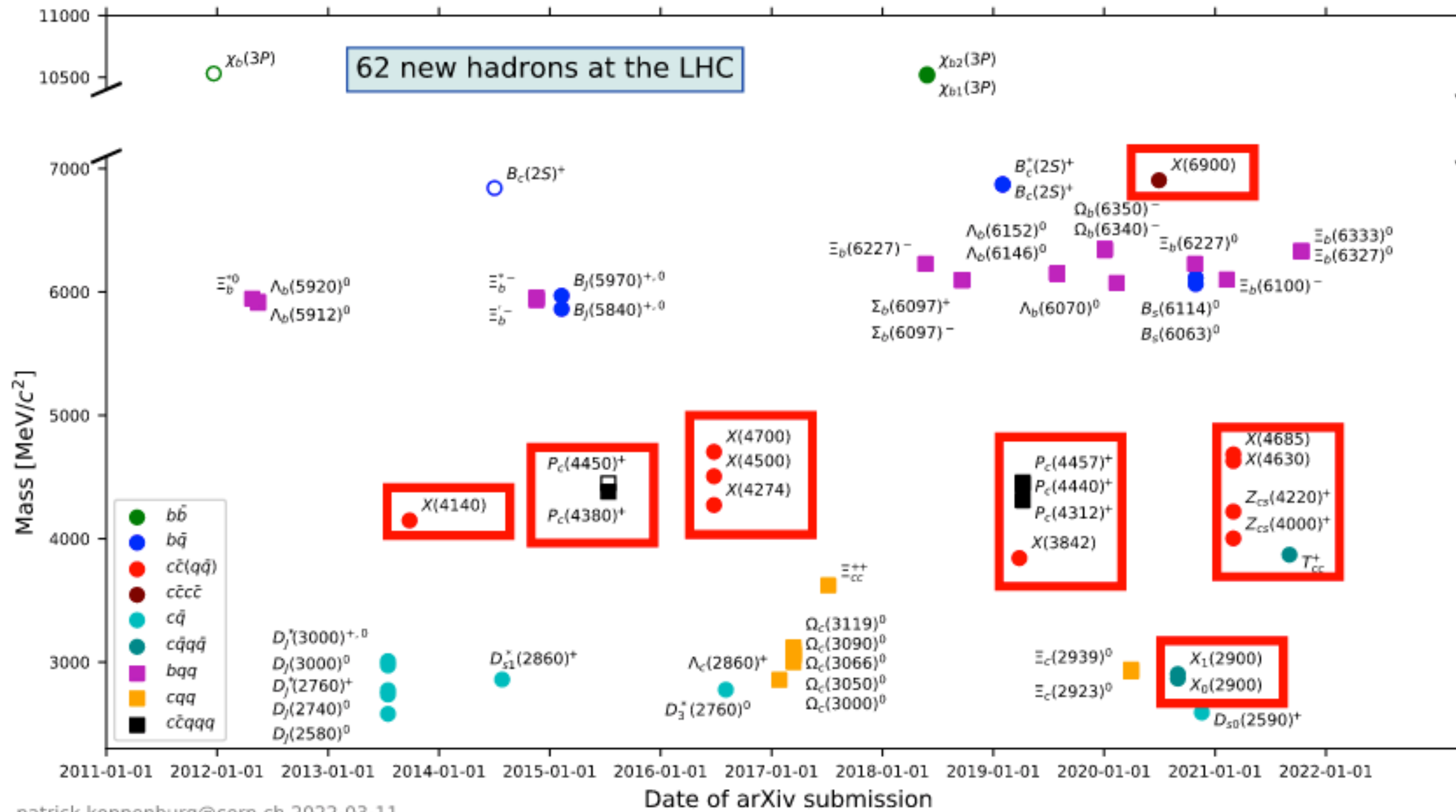

ALICE 3 muonID: muons down to low p_T (~ 1.5 GeV/c at $\eta = 0$) \rightarrow unique p_T reach to study the formation and dissociation of e.g. X(3872) in HIC at thermal momentum scales.

CMS: $p_T > 10$ GeV/c.

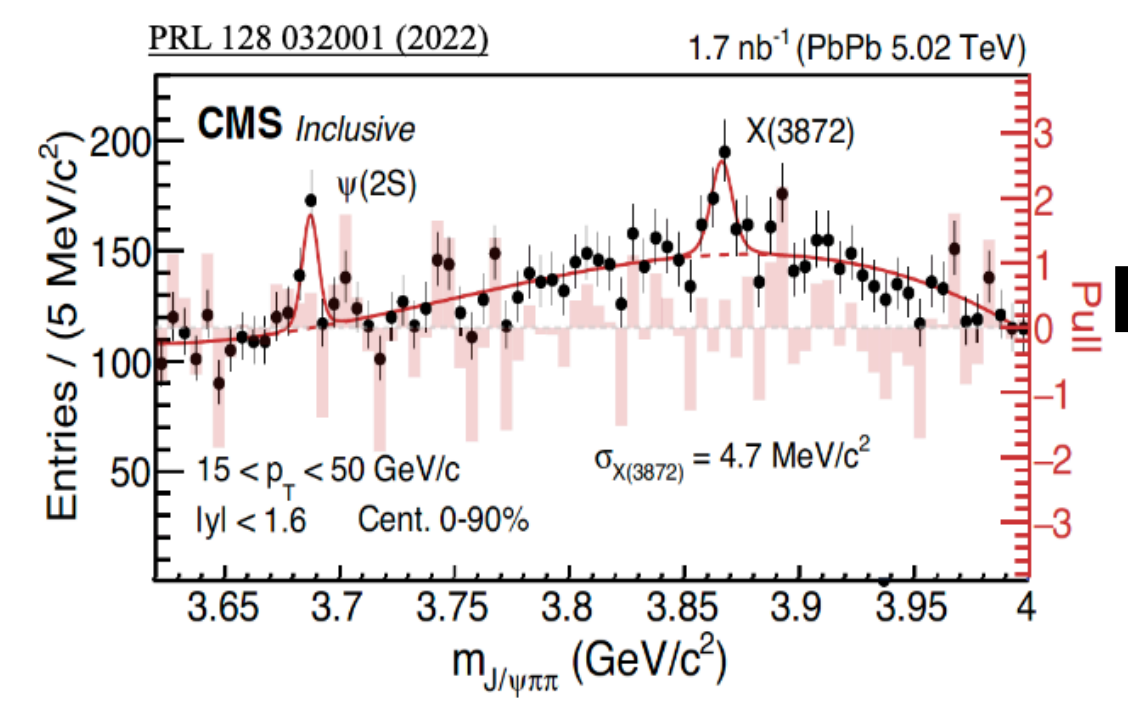

pp vs flatenicity/multiplicity?

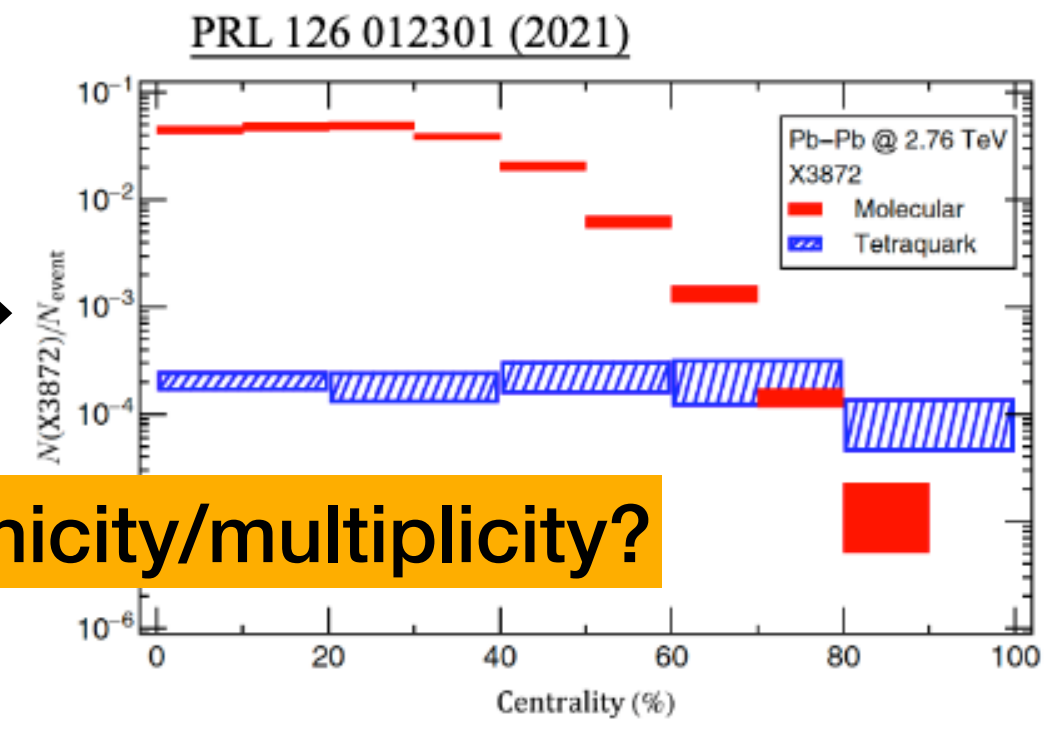

- Expected enhancement of multi-charm states provides high sensitivity to equilibration
- Systematic measurement of hadron yields
 - Luminosity, acceptance, vertexing, PID, strangeness tracking

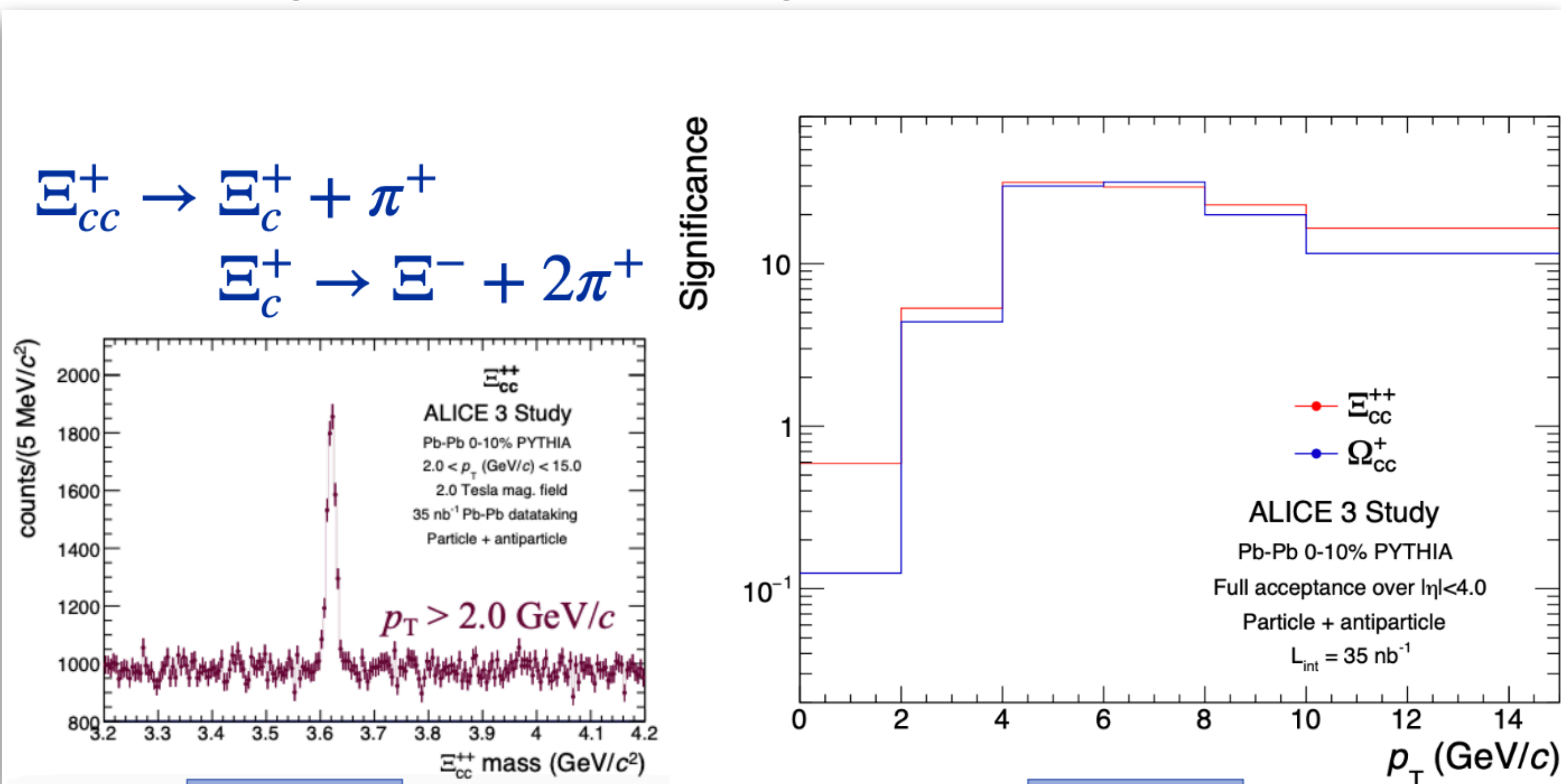

Hadron yields in statistical hadronisation model

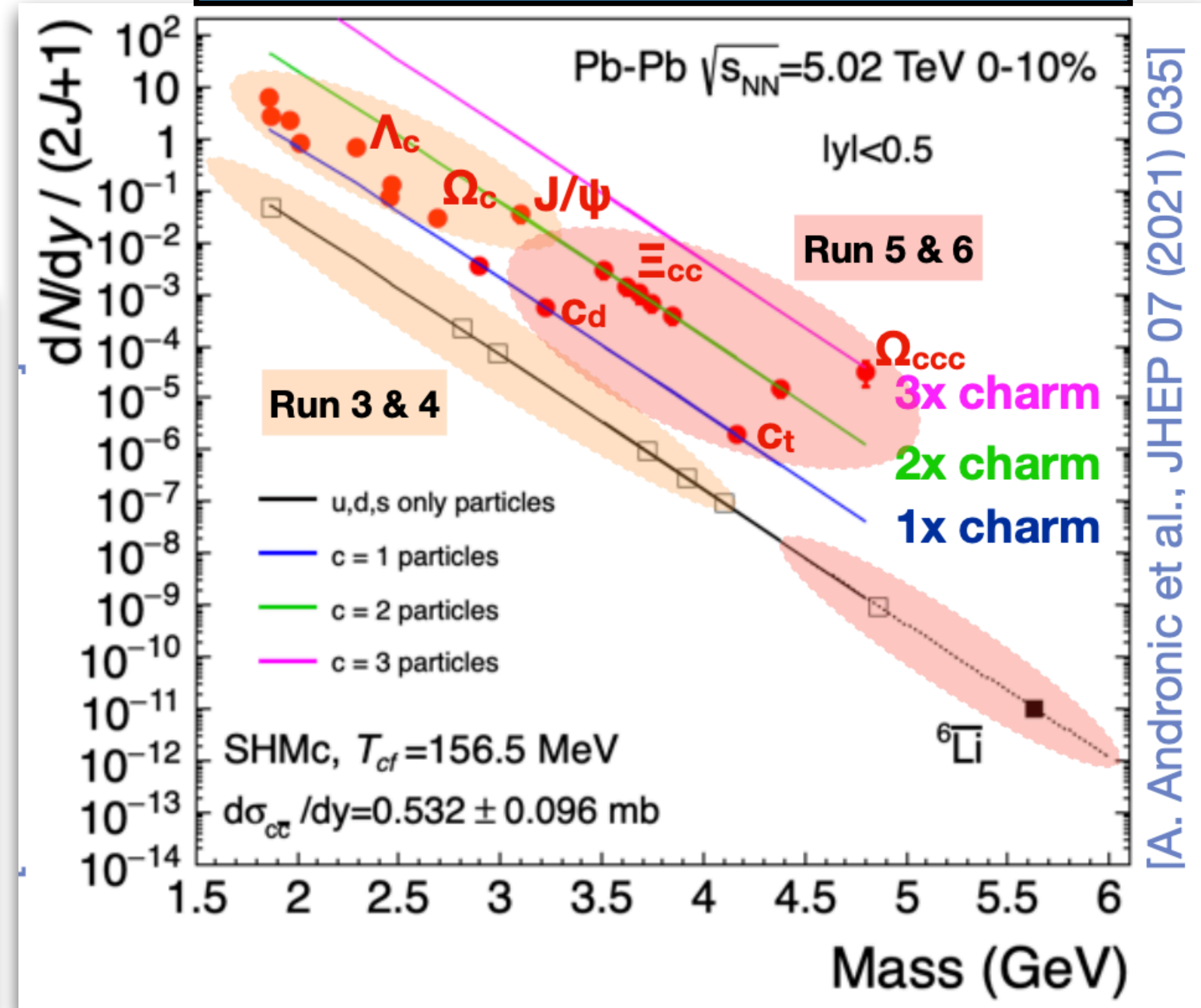

[A. Andronic et al., JHEP 07 (2021) 035]

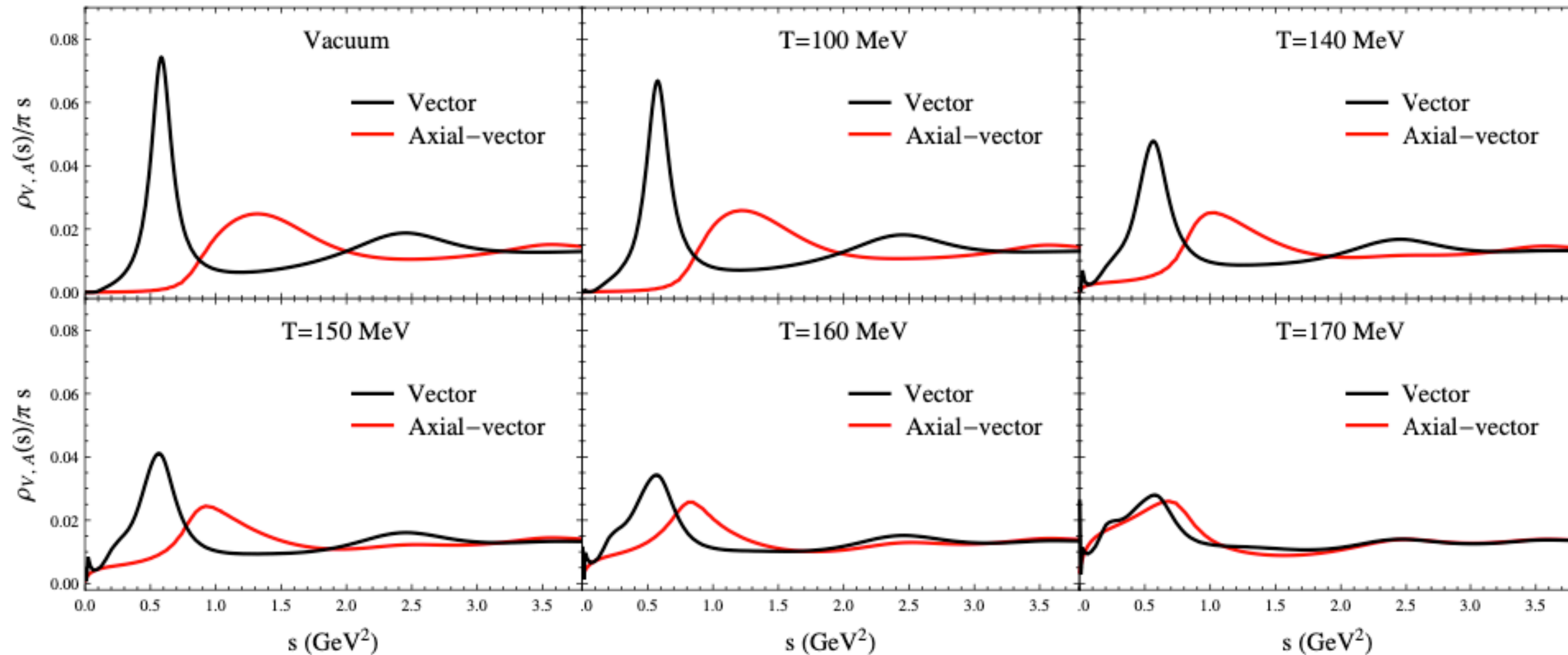
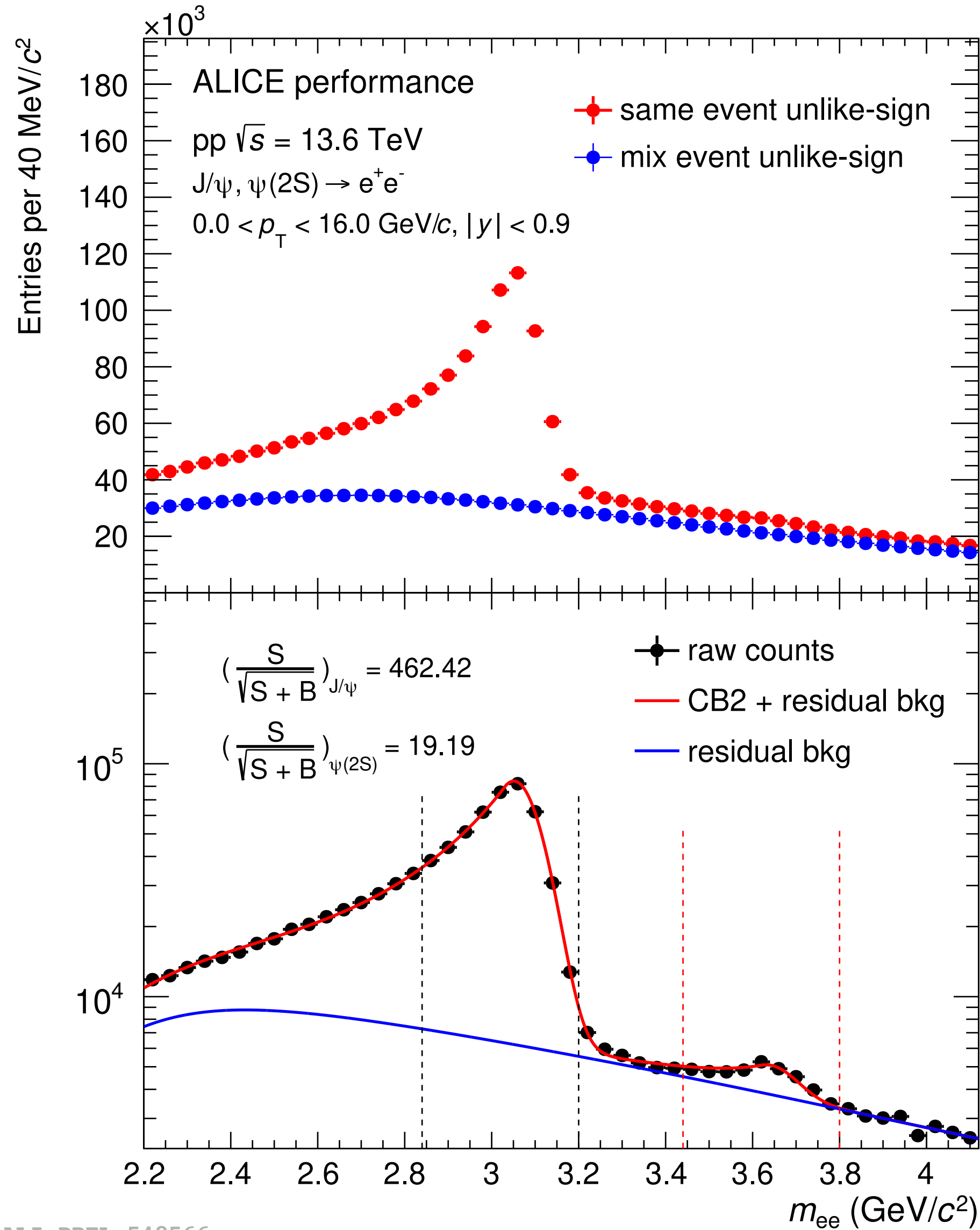
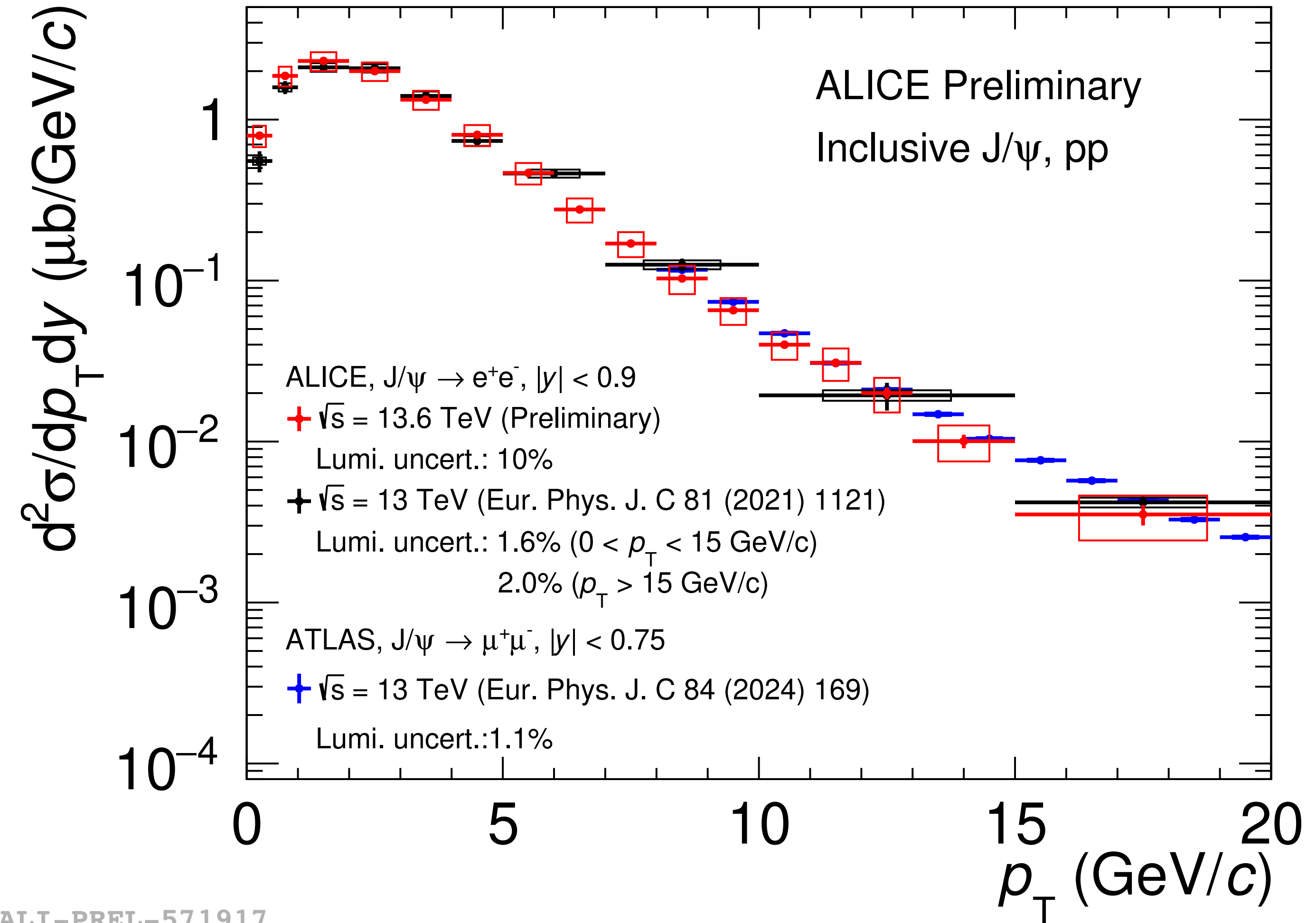

Figure 5: Temperature evolution of vector and axial-vector spectral functions (non-linear realization) [132].

J/ψ production



ALI-PREL-548566



ALI-PREL-571917

e^+e^- decays: down to $p_T = 0$, excellent precision
Important input to quarkonia production models

Baryon to meson ratio: heavy quarks

ALICE, JHEP12(2023)086

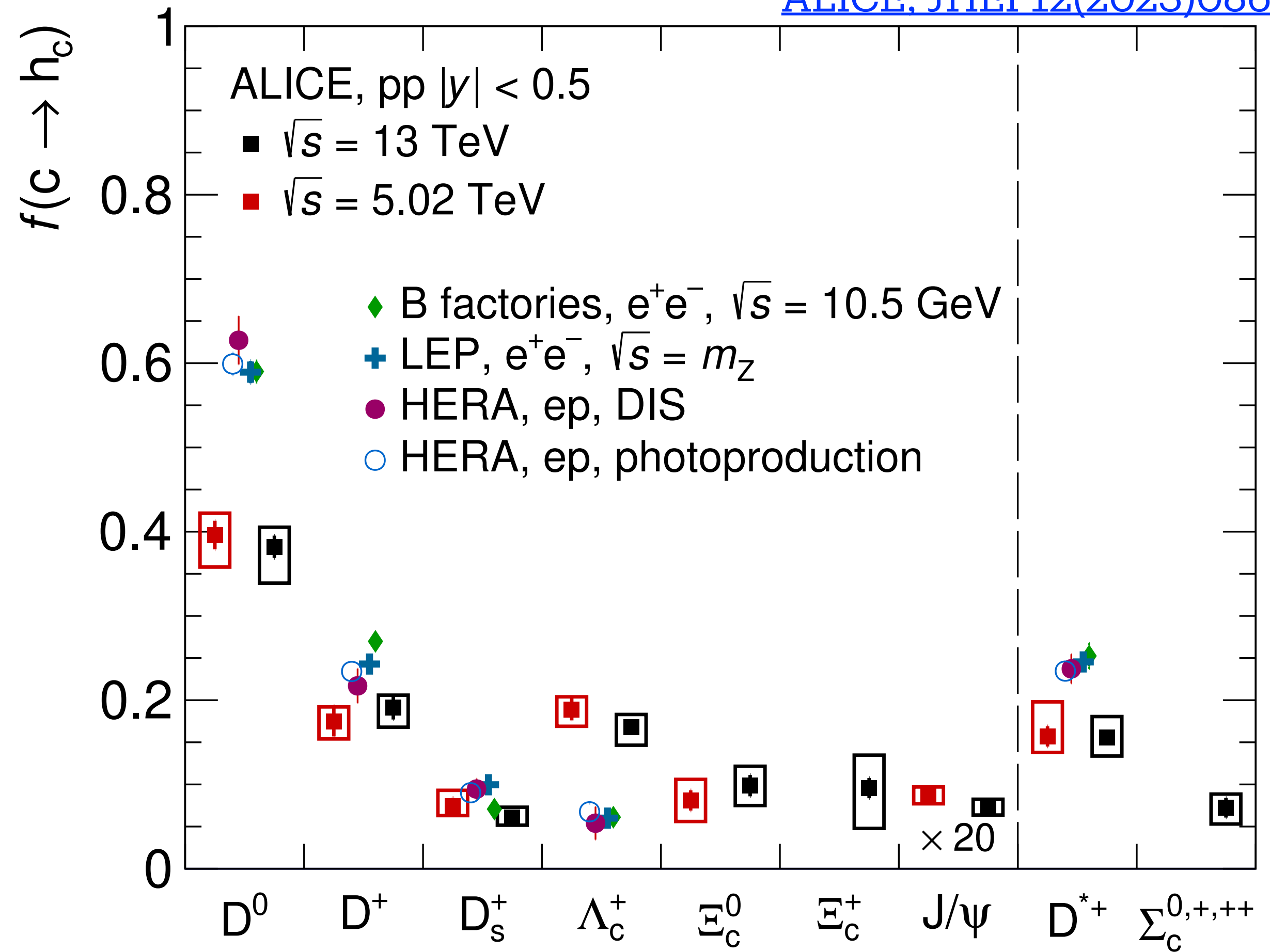

ALICE, PRD 108, 112003 (2023)

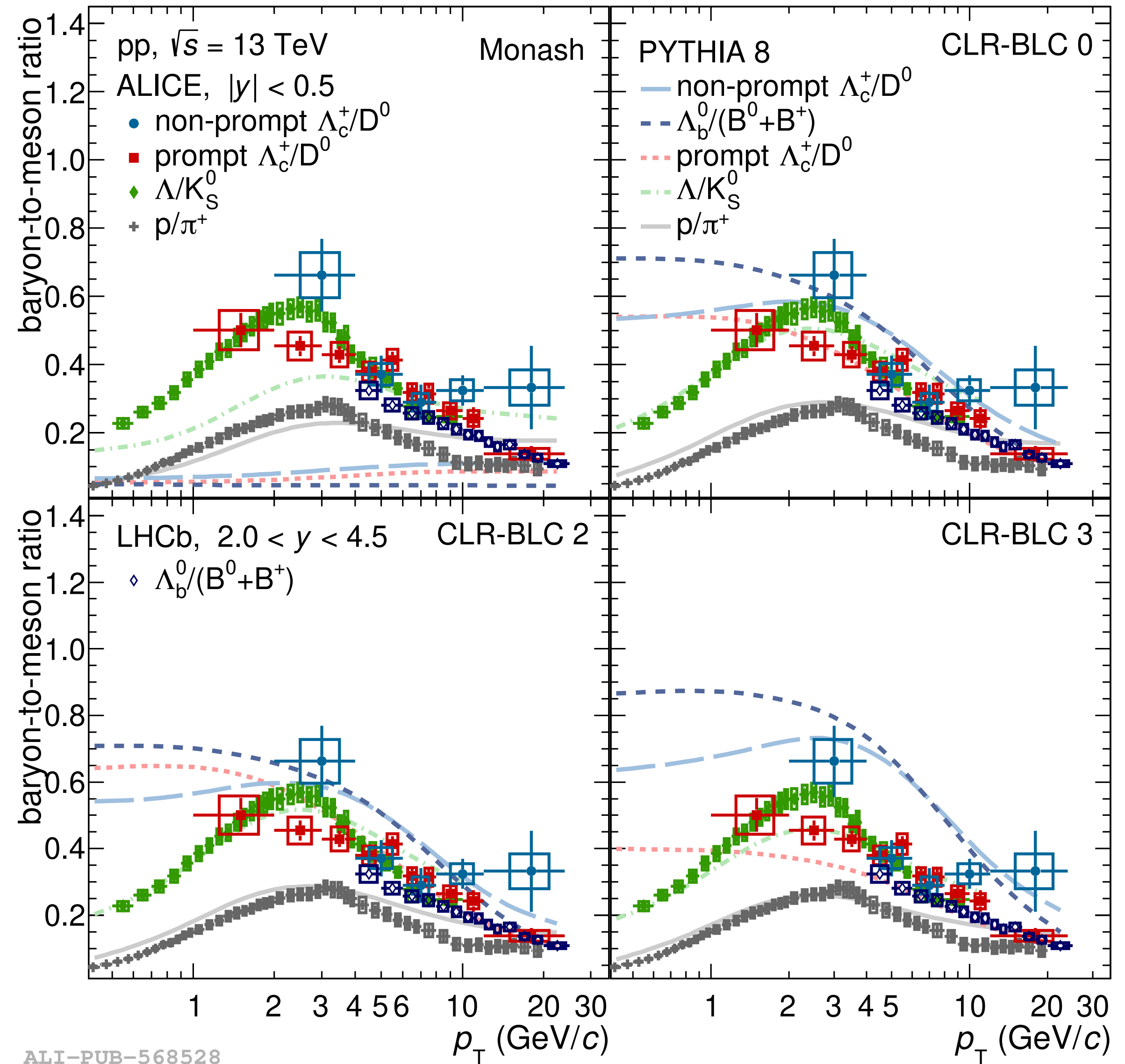

ALI-PUB-567906

- ◆ Baryon production larger in pp than e^+e^-
- ◆ Baryon enhancement also present in beauty sector

ALI-PUB-568528

Ω_c^0 branching ratios

[ALICE, PRD 110 \(2024\) 032014](#)

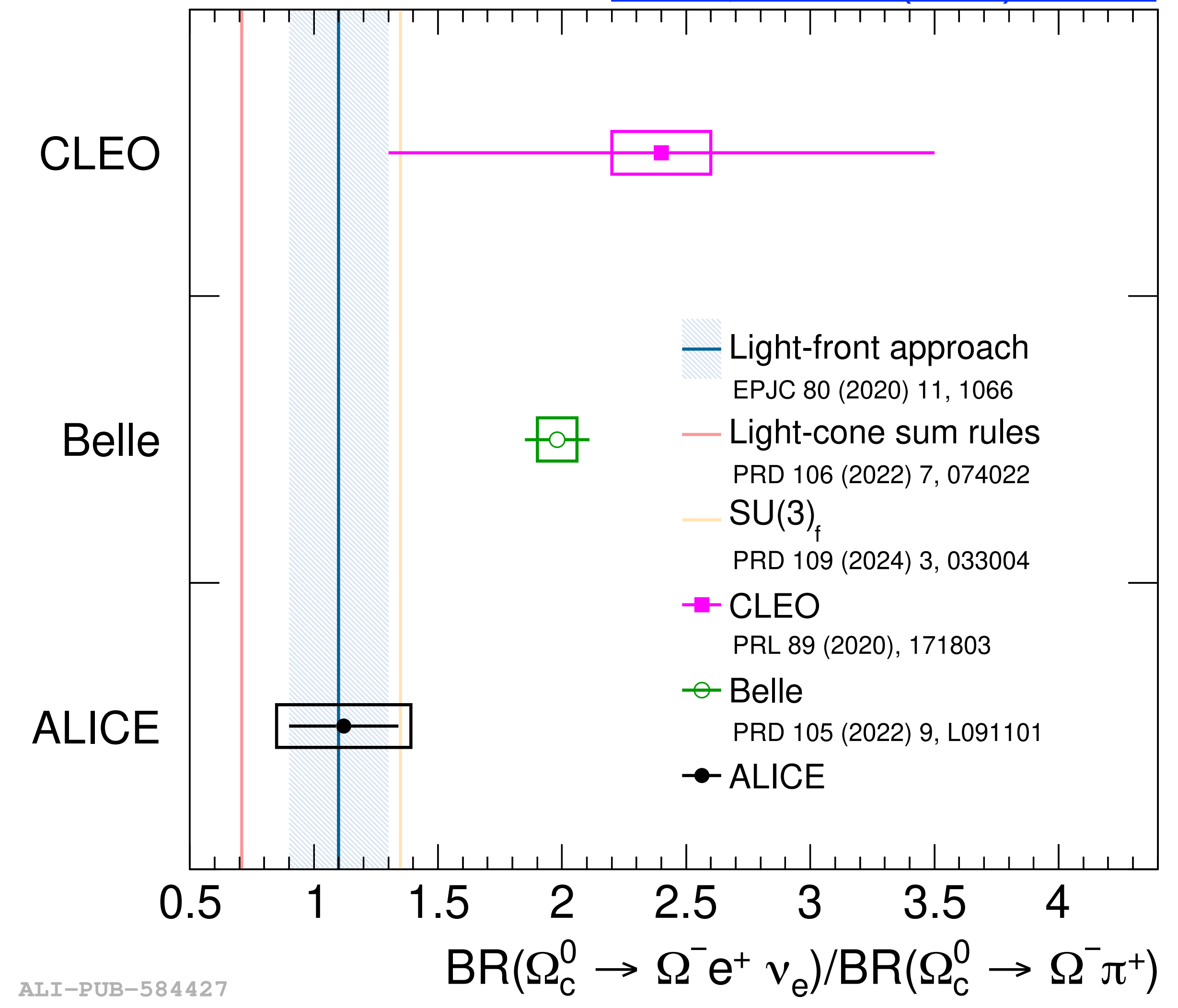
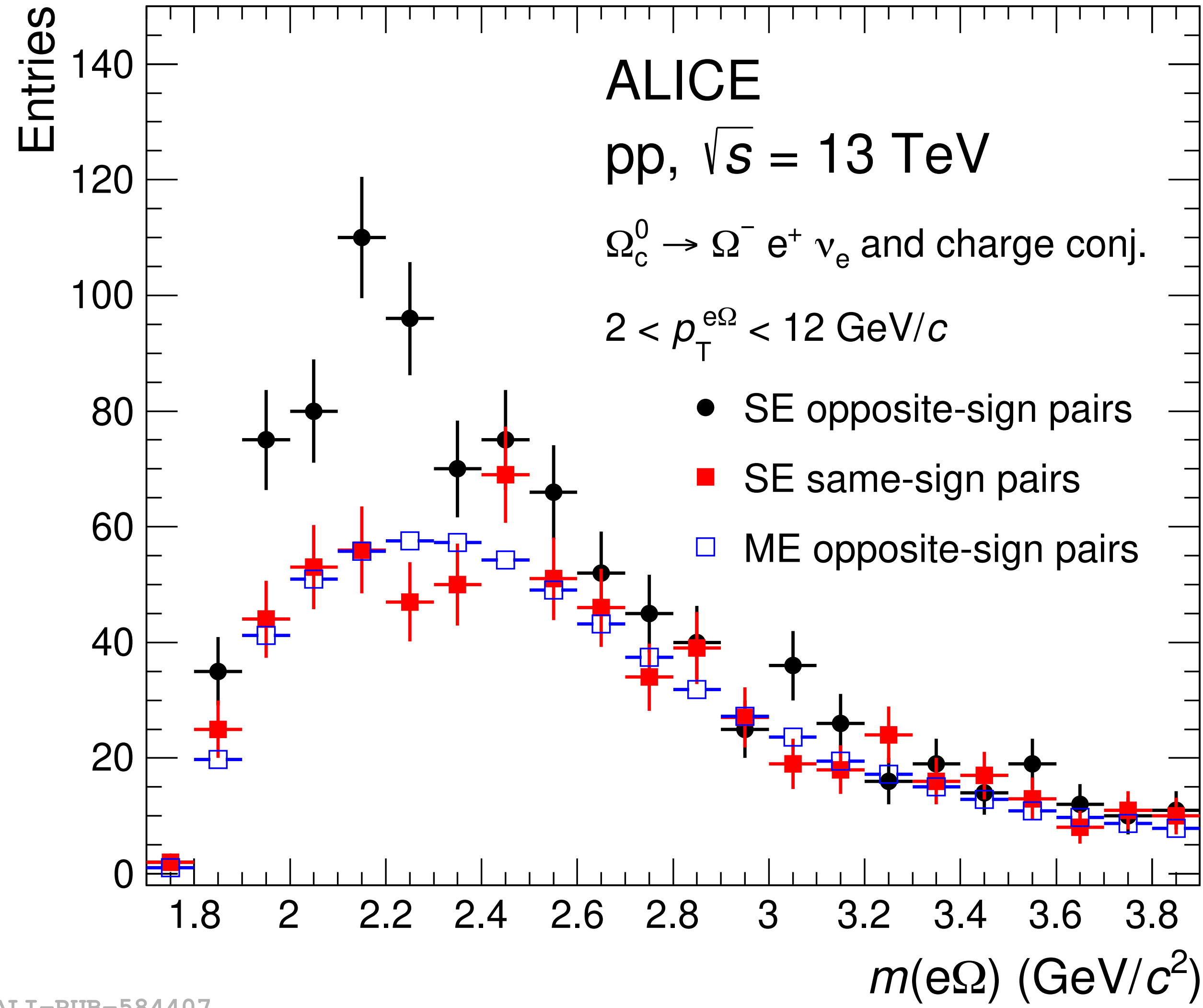

ALI-PUB-584407

ALI-PUB-584427

Charm baryon branching ratios: input to understanding charm baryon production

Upgrades beyond LS4

Measurements beyond Run 4

Further progress relies on

- ◆ Precision measurements of dileptons
- ◆ evolution of the QGP / mechanisms of chiral symmetry restoration in the QGP

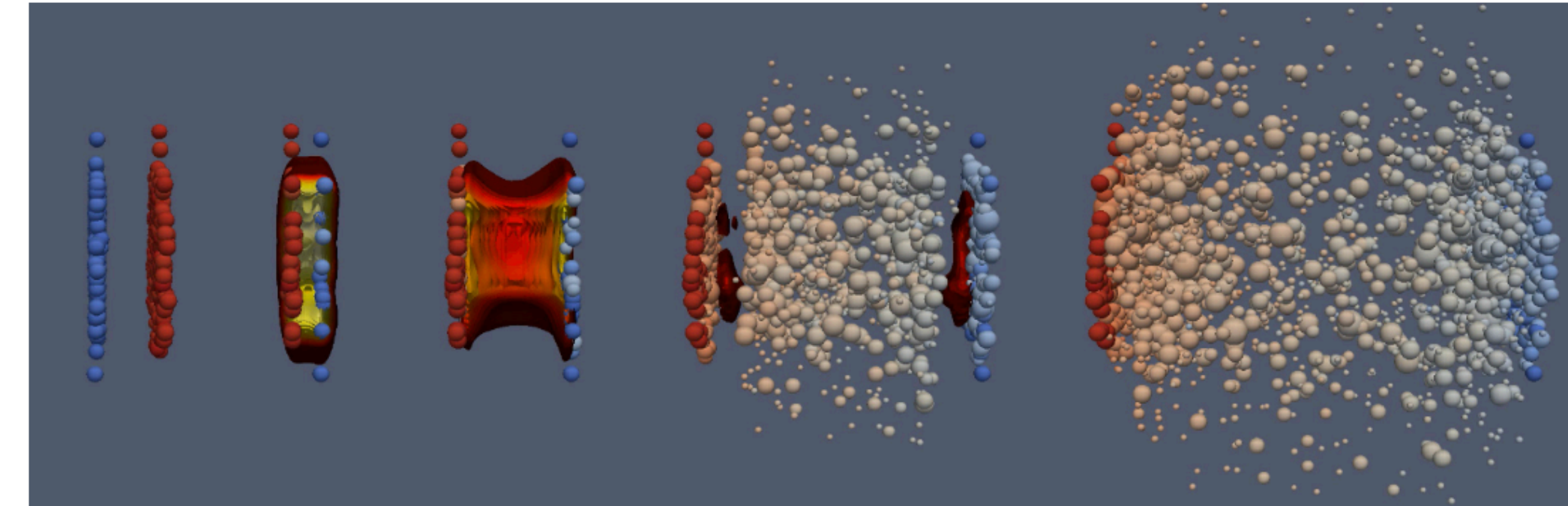
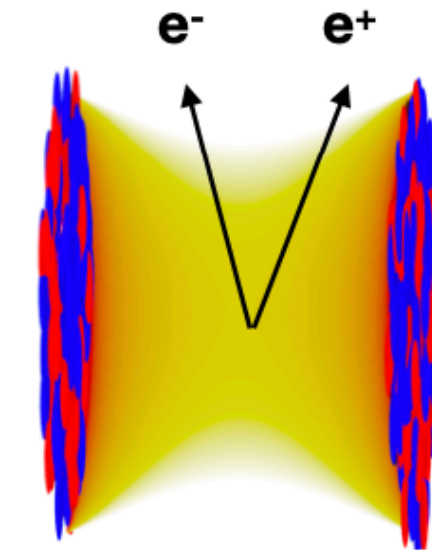

- ◆ Systematic measurements of (multi-)heavy-flavoured hadrons
- ◆ transport properties in the QGP / mechanisms of hadronisation from the QGP

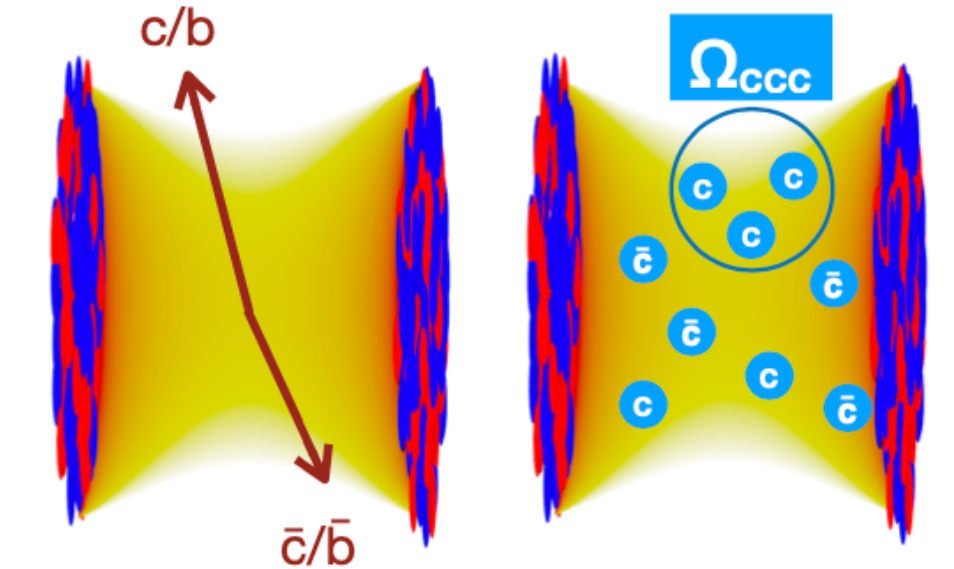

- ◆ Collectivity in small systems

- ◆ ALICE 3 would open an unique opportunity to fully understand the origin of collectivity in small systems

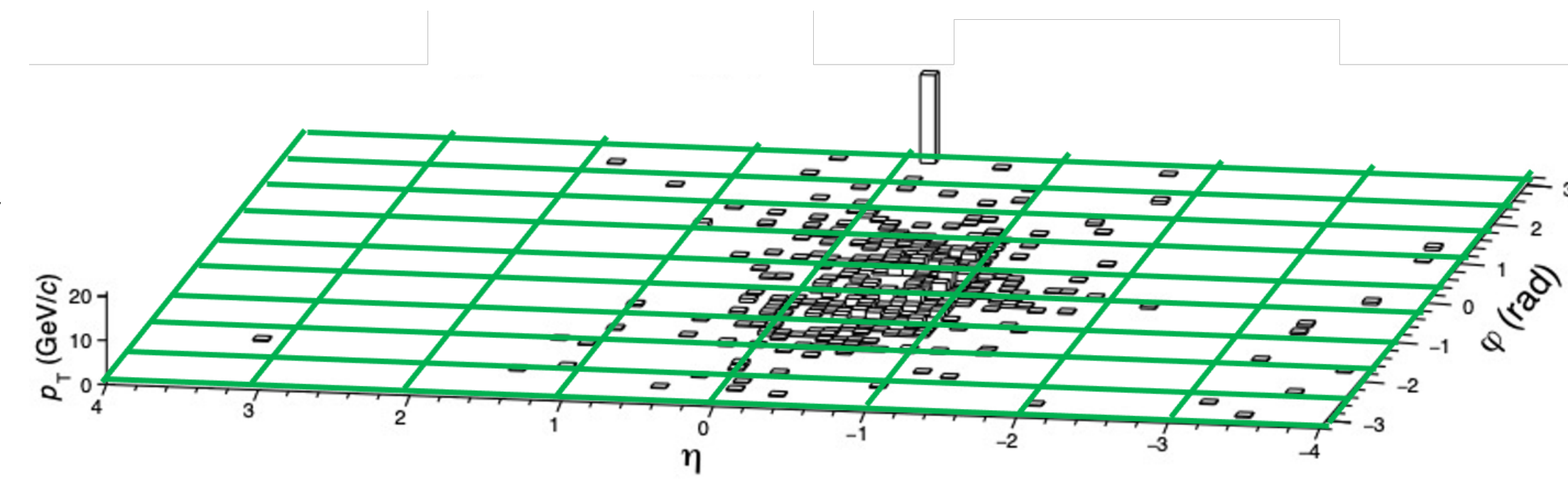

Probes

- ◆ Heavy-flavour hadrons ($p_T \rightarrow 0$, wide η range)
 - ◆ vertexing, tracking, hadron ID
- ◆ Dileptons ($p_T \approx 0.1 - 3 \text{ GeV}/c$, $M_{ee} \approx 0.1 - 4 \text{ GeV}/c^2$)
 - ◆ vertexing, tracking, lepton ID
- ◆ Photons ($0.1 - 50 \text{ GeV}/c$, wide η range)
 - ◆ electromagnetic calorimetry
- ◆ Quarkonia and Exotica ($p_T \rightarrow 0$)
 - ◆ muon ID
- ◆ Jets
 - ◆ tracking and calorimetry, hadron ID

Qualitative steps needed in
detector performance and
statistics
→
next-generation heavy-ion
experiment

Detector requirements (LoI)

Component	Observables	Barrel ($ \eta < 1.75$)	Forward ($1.75 < \eta < 4$)	Detectors
Vertexing	(Multi-) charm baryons, dielectrons	Best possible DCA resolution, $\sigma_{\text{DCA}} \approx 1 \mu\text{m}$ at $p_{\text{T}} = 200 \text{ MeV}/c$, $\eta = 0$	Best possible DCA resolution, $\sigma_{\text{DCA}} \approx 30 \mu\text{m}$ at $p_{\text{T}} = 200 \text{ MeV}/c$, $\eta = 3$	Retractable Si-pixel tracker: $\sigma_{\text{pos}} \approx 2.5 \mu\text{m}$, $R_{\text{in}} \approx 5 \text{ mm}$, $X/X_0 \approx 0.1 \%$ for the first layer
Tracking	(Multi-) charm baryons, dielectrons, photons ...	$\sigma_{p_{\text{T}}}/p_{\text{T}} \approx 1 - 2 \%$		Silicon pixel tracker: $\sigma_{\text{pos}} \approx 10 \mu\text{m}$, $R_{\text{out}} \approx 80 \text{ cm}$, $L \approx \pm 4 \text{ m}$, $X/X_0 \approx 1 \%$ per layer
Hadron ID	(Multi-) charm baryons	$\pi/\text{K}/p$ separation up to a few GeV/c		Time of flight: $\sigma_{\text{tof}} \approx 20 \text{ ps}$ RICH: $n \approx 1.006 - 1.030$, $\sigma_{\theta} \approx 1.5 \text{ rad}$
Electron ID	Dielectrons, quarkonia, $\chi_{\text{c1}}(3872)$	Pion rejection by 1000x top to 2-3 GeV/c		Time of flight: $\sigma_{\text{tof}} \approx 20 \text{ ps}$ RICH: $n \approx 1.006 - 1.030$, $\sigma_{\theta} \approx 1.5 \text{ rad}$
Muon ID	Quarkonia, $\chi_{\text{c1}}(3872)$	Reconstruction of J/ψ at rest, i.e. muons from $p_{\text{T}} \approx 1.5 \text{ GeV}/c$ at $\eta = 0$		Steel absorber: $L \approx 70 \text{ cm}$ muon chambers (scintillators, RPCs or MWPC)