

Optimization in the search for rare Higgs processes during the HL-LHC using AI algorithms

Alfredo Castaneda
University of Sonora

XXXIV Annual meeting DPyC-SMF

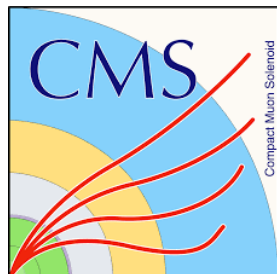

Motivation

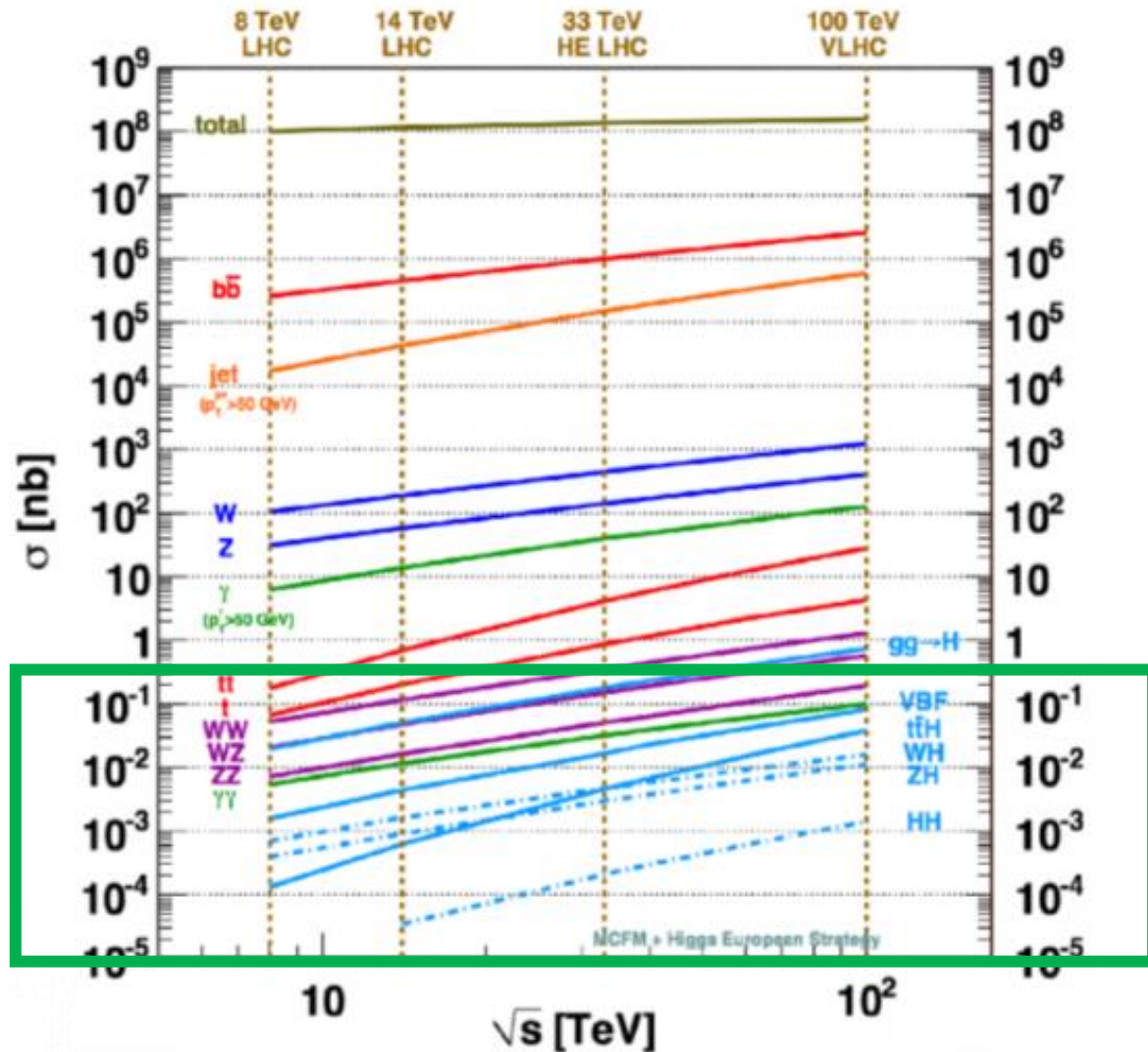

- The LHC and future accelerators (FCC) will allow scientists to measure “rare” processes both in SM and BSM
- With the data collected so far processes as double Higgs production and some Higgs decays are not accessible yet
- Two things are needed:
 - More Luminosity (~ 10 times more)
 - Better methods to separate signal and background

High Luminosity LHC

LHC / HL-LHC Plan



High
Luminosity
LHC

BUL-NA-2014-272

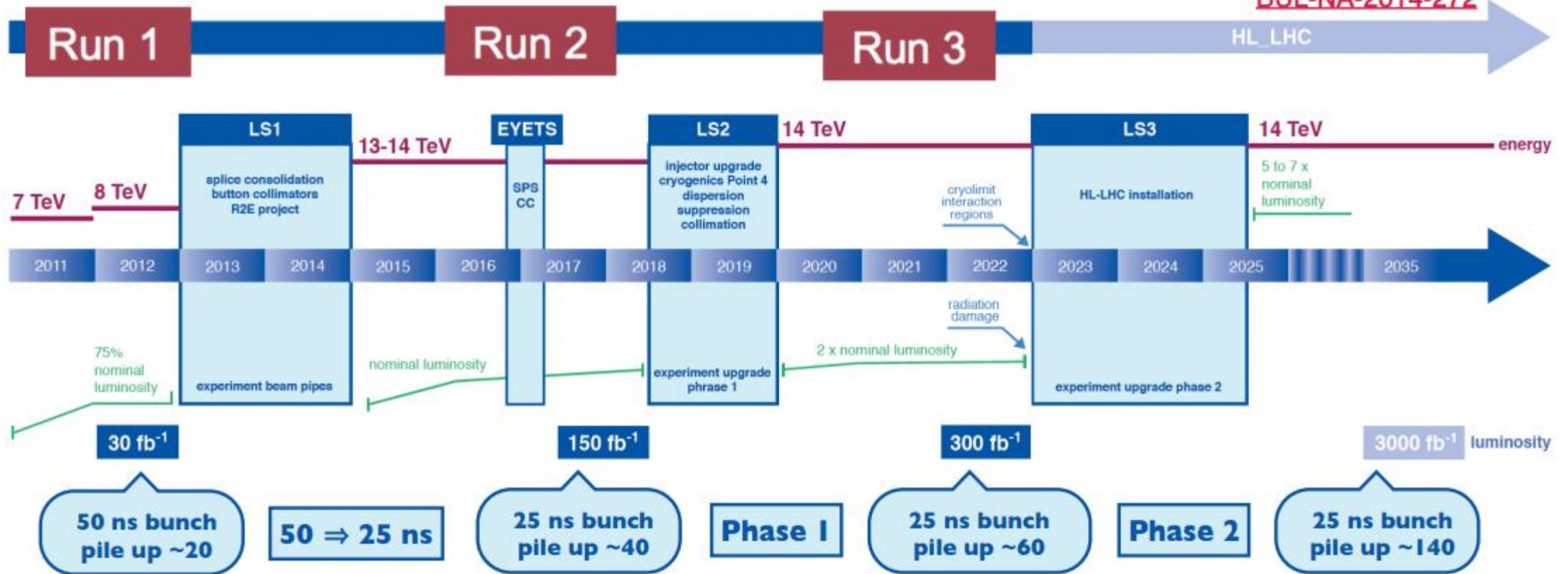

Traditional vs alternative analysis methods

Cut-based analysis

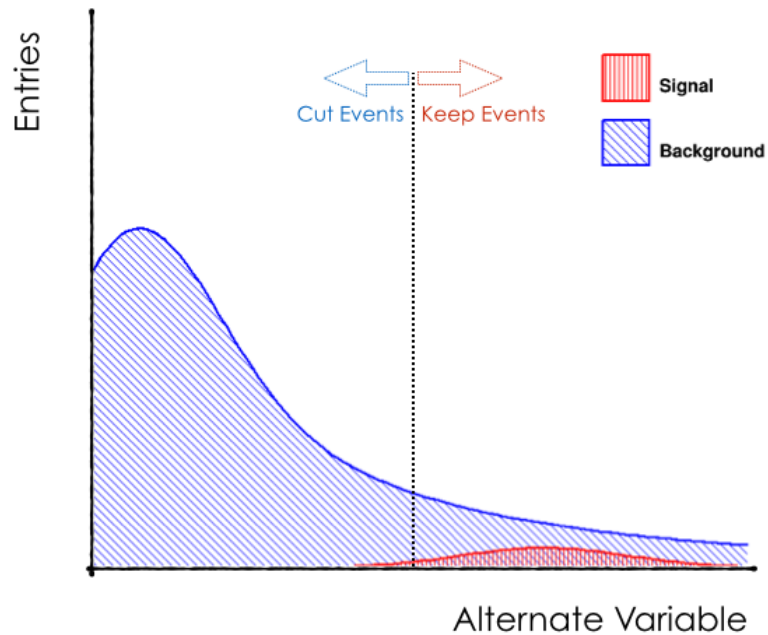

- Based on basic physics assumptions, easy interpretation of systematics
- Not optimized separation of signal and background

Artificial Neural networks

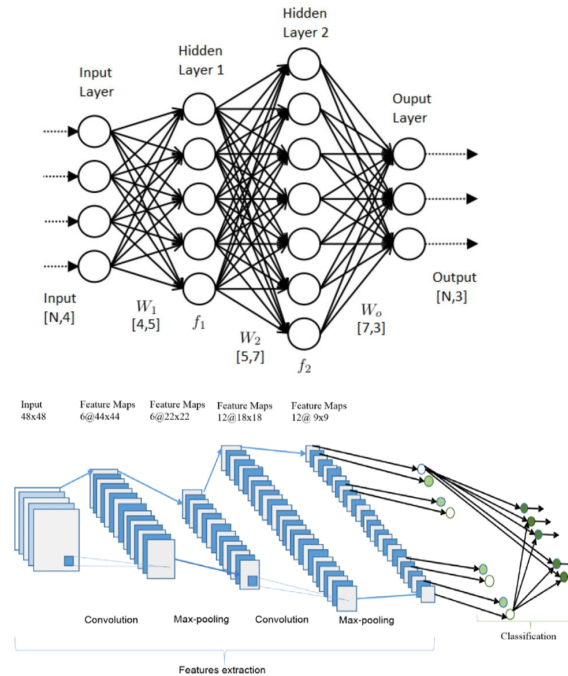

- Optimized method to separate signal and background
- Not relying only on first physics principles
- Difficult to assign a systematic uncertainty

Boosted Decision Trees

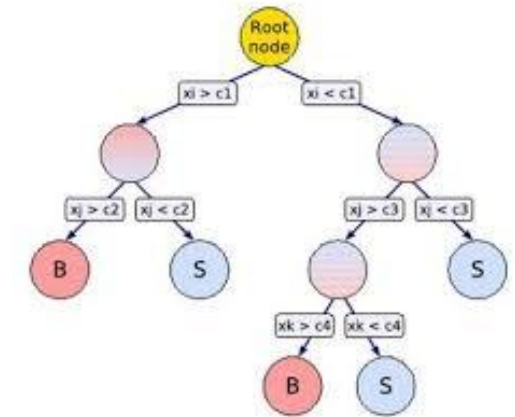

Artificial neural networks in a nutshell

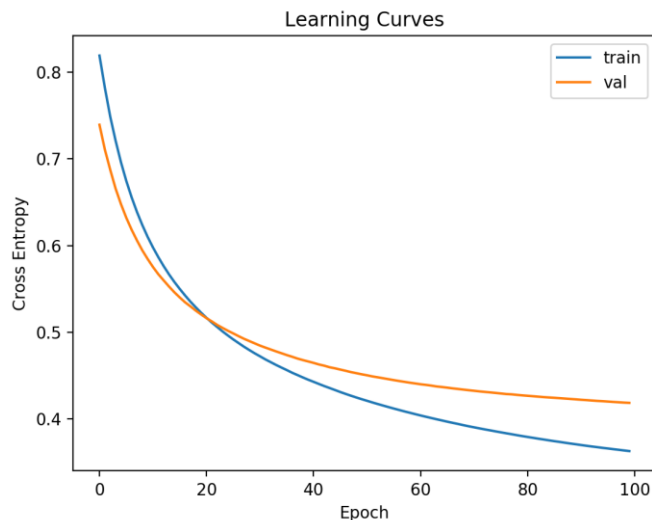
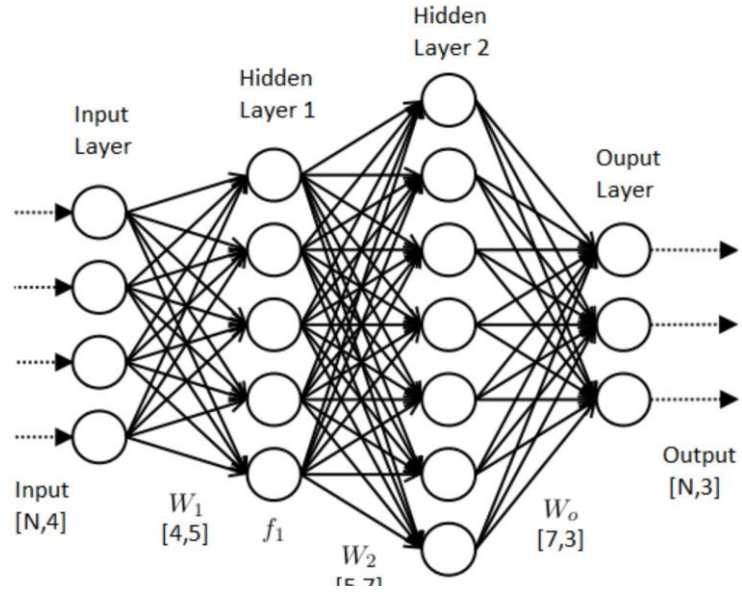

- ANN are composed of layers or artificial neurons interconnected by a weight factor
- The first layer is the input data, which usually is a collection of variables
- A learning step is completed once output is compared to the “true” answer (i.e. signal/background) if the results is wrong the weights are updated (using an error minimization process) and the sequence is repeated
- In every iteration the error decreases, once a threshold is achieving the model is declared as trained

Convolutional neural networks in a nutshell

- CNN are a type of network designed to process data as images
- In HEP is extensively used to identify jets and classify according to origin and flavor

Gluon initiated jet

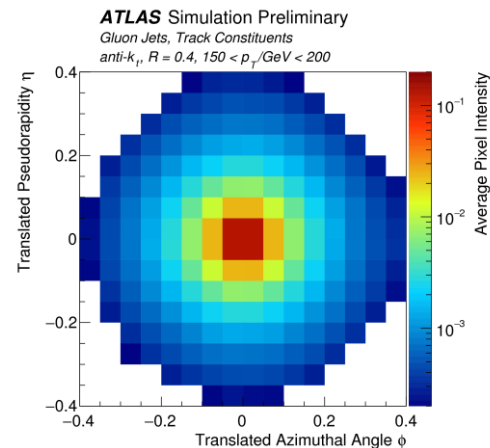

Quark initiated jet

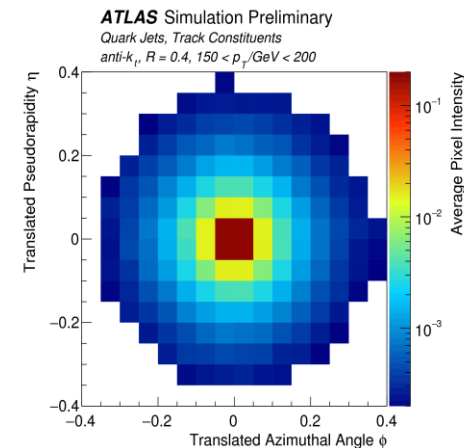

ATLAS Simulation Preliminary

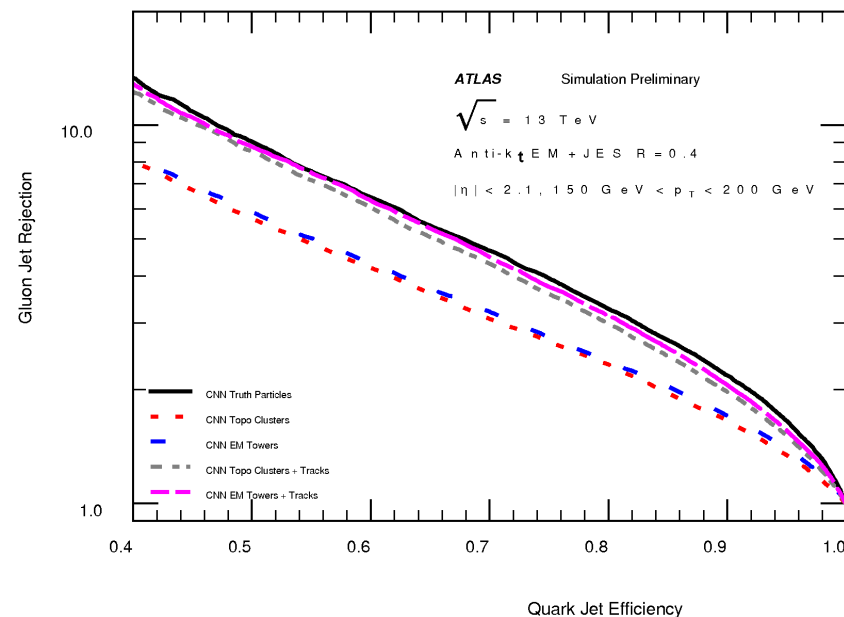
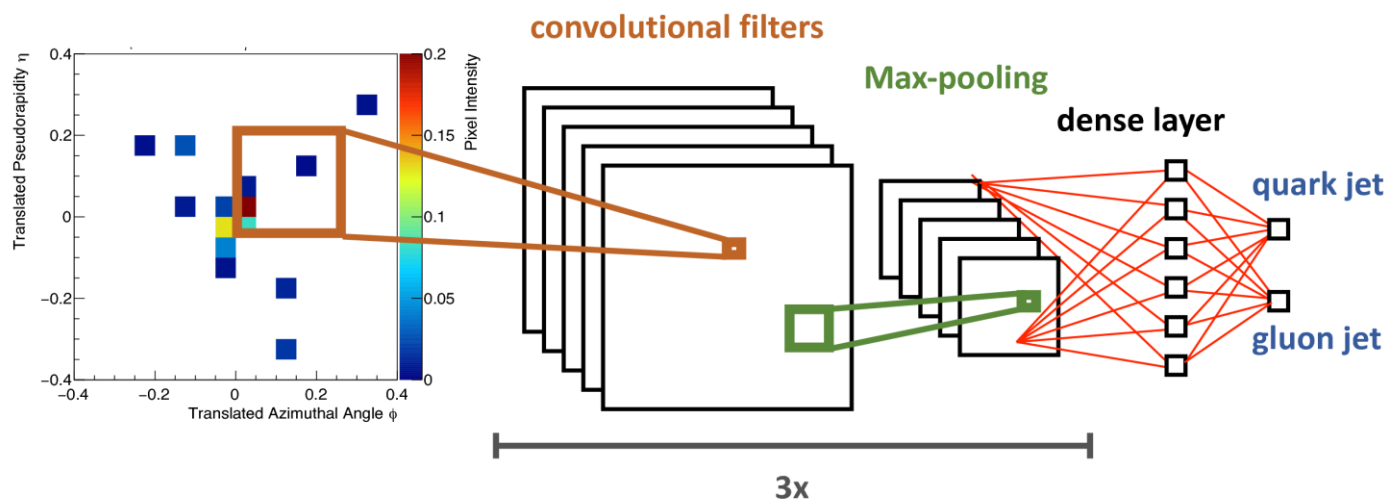

Boosted Decision Trees

- Decision Trees are non-parametric supervised learning
- Decision Trees learn from the data
- Each terminal node representing the entropy to find a way to split the set until all data belongs to the same class
- The output of a BDT is a classifier between -1 and 1

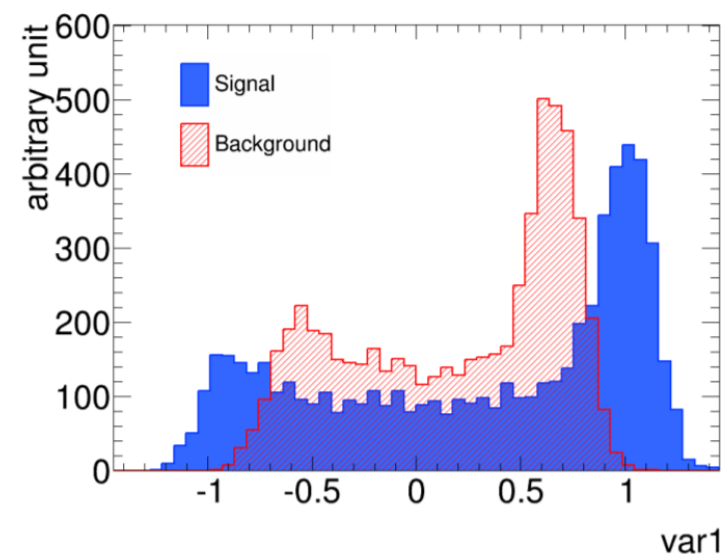
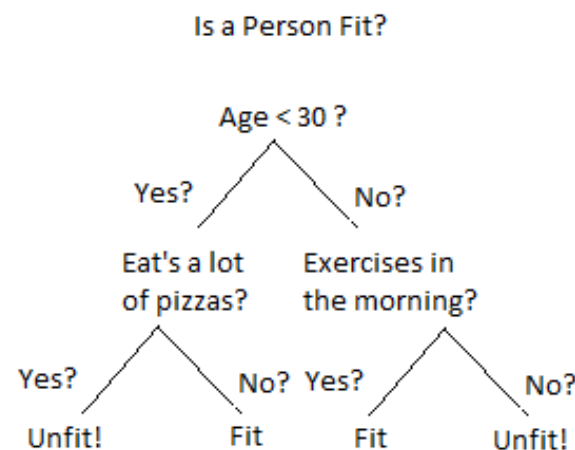
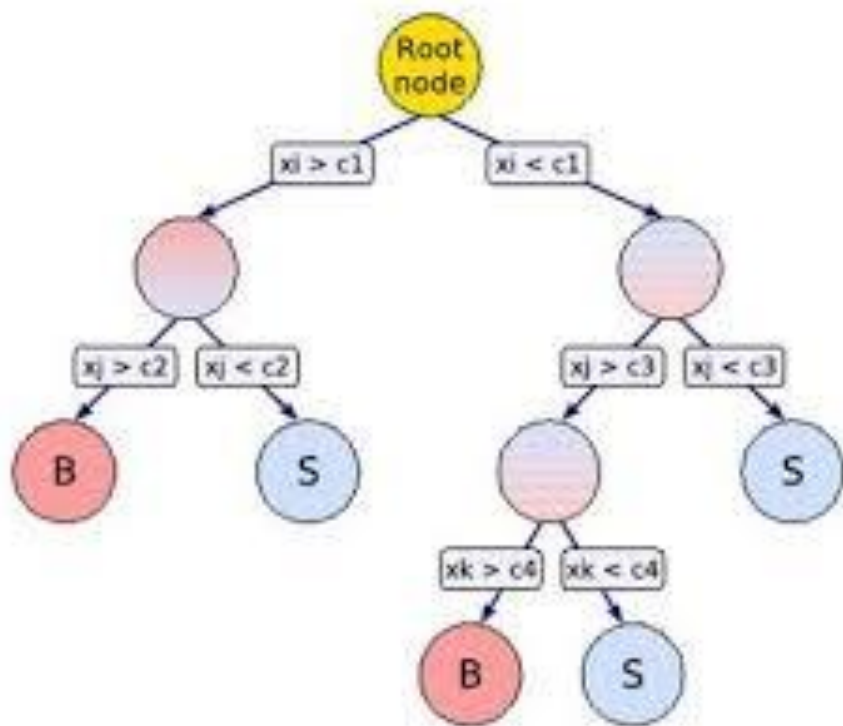

Computational resources

- ❑ In order to use these alternative methods a combination of common CERN tools and GPU graphics card processing is needed
- ❑ Training data is obtained commonly from MC simulated samples (signal and background)
- ❑ Basic event selection to obtain input for neural network
- ❑ Training of NN with common tools (Tensorflow, Keras) and clusters of GPU cards for accelerating the process
- ❑ Interpretation of results

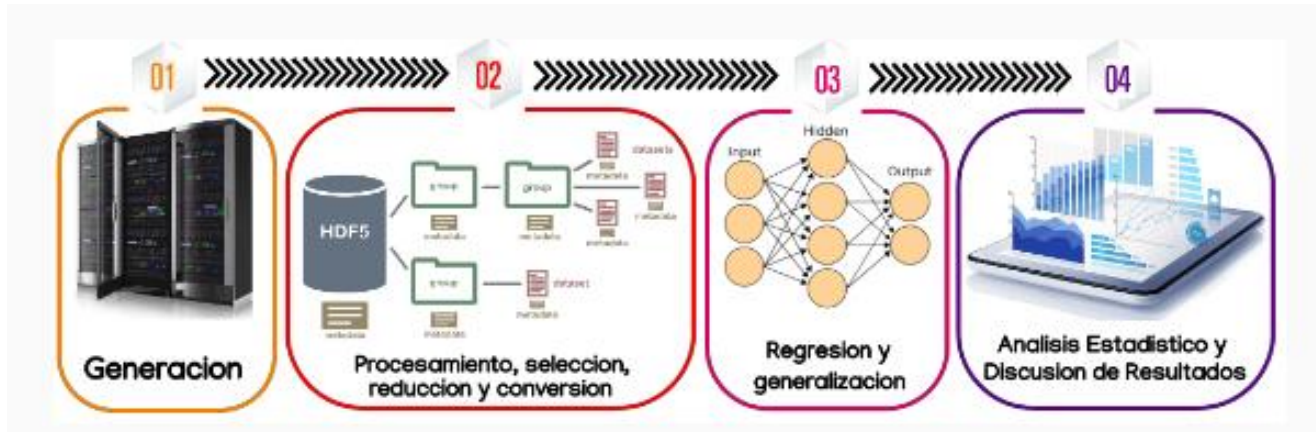

Rare processes

- As example we will mention three processes that share at least two of the following characteristics:
 - ❑ Low Cross section and Branching ratios
 - ❑ Large background contribution
 - ❑ Large object multiplicity

H to $\mu\mu$

- Higgs decay to a pair of opposite muons would provide the first evidence of Higgs couplings to fermions (outside third generation)
- This search is difficult because the low branching ratio (~ 0.022) and large background contribution

	gluon-fusion	VBF	VH	$t\bar{t}H$
Cross sections (pb)	44.08	3.76	2.25	0.51

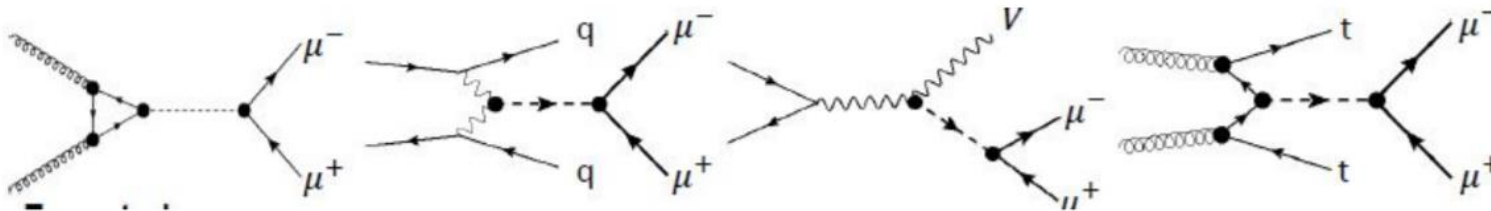

Simulated Higgs to dimuon

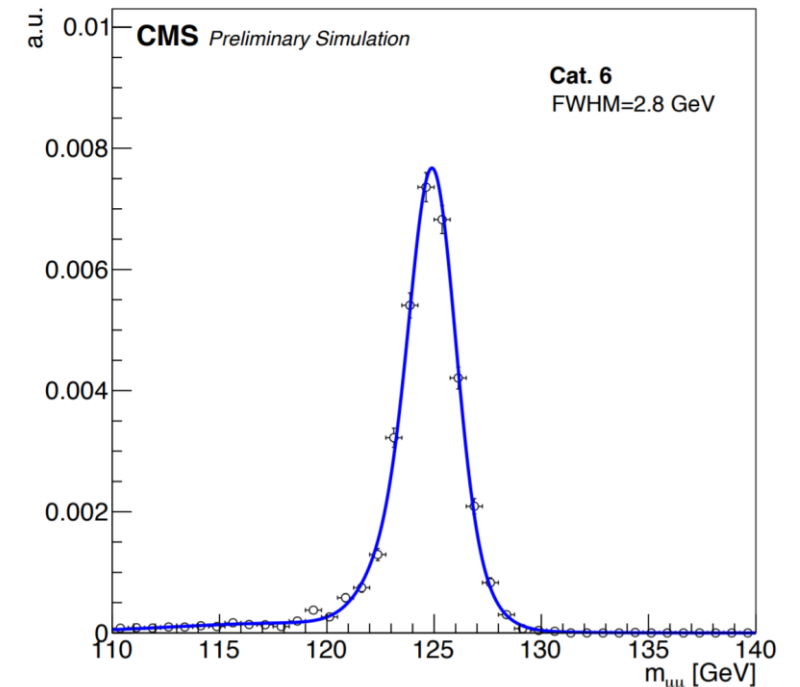

H to $\mu\mu$

- BDT classifier is built using following kinematical variables:

- The p_T and η of the dimuon system
- The $|\delta\eta|$ and $|\delta\phi|$ between the muons
- The η values of the two highest- p_T jets
- The masses of the two highest-mass dijet pairs
- The $|\delta\eta|$ between the jets in the two highest-mass pairs
- The number of jets with $|\eta| < 2.4$ and $|\eta| > 2.4$
- The number of jets identified as coming from b-hadrons [8]
- The missing transverse energy E_T .

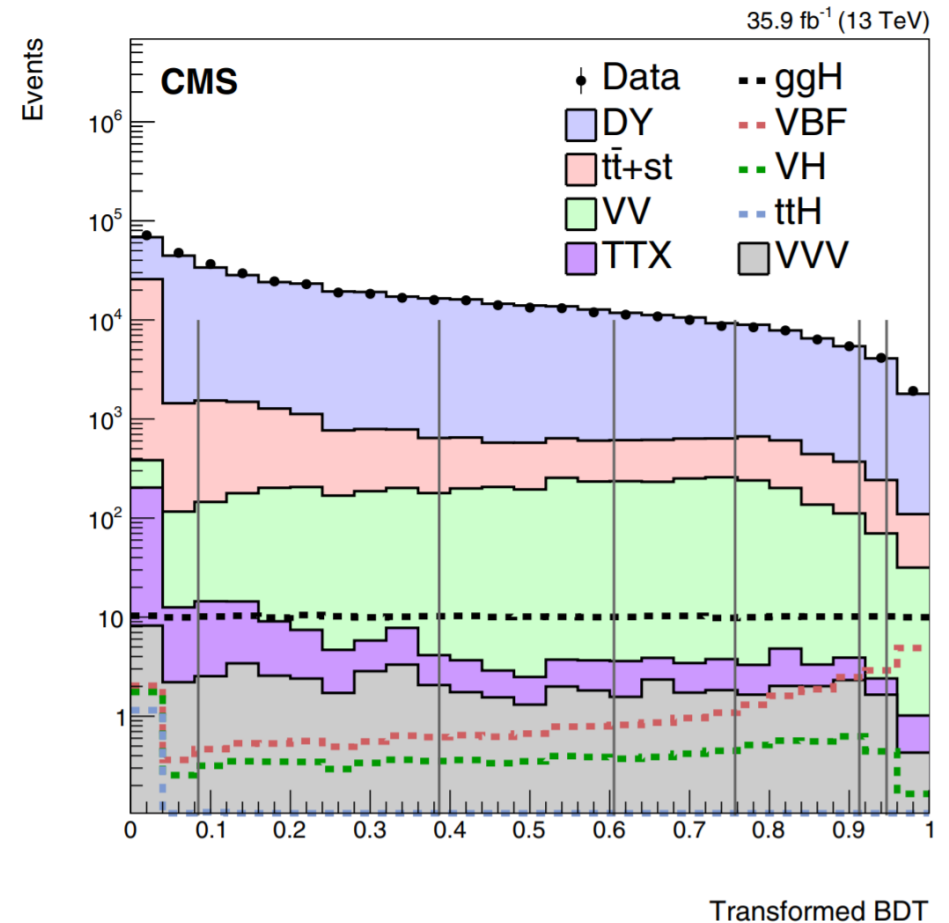

H to $\mu\mu$

BDT response		Muon $ \eta $	ggH	VBF	WH	ZH	$t\bar{t}H$	Signal	Bkg./GeV	FWHM	S/\sqrt{B}
quantile [%]		range	[%]	[%]	[%]	[%]	[%]		@ 125 GeV	[GeV]	@ FWHM
0	8	0.0-2.4	4.9	1.3	3.3	6.3	32	21.2	3.13×10^3	4.2	0.12
8	39	1.9-2.4	5.6	1.7	3.9	3.5	1.3	22.3	1.34×10^3	7.2	0.16
8	39	0.9-1.9	10	2.8	6.5	6.4	5.2	41.1	2.24×10^3	4.1	0.29
8	39	0.0-0.9	3.2	0.8	1.9	2.1	3.5	12.7	7.83×10^2	2.9	0.18
39	61	1.9-2.4	2.9	1.7	2.7	2.7	0.3	11.8	4.37×10^2	7.0	0.14
39	61	0.9-1.9	7.2	3.3	6.1	5.2	1.3	29.2	9.70×10^2	4.0	0.31
39	61	0.0-0.9	3.6	1.1	2.6	2.2	0.9	14.5	4.81×10^2	2.8	0.26
61	76	1.9-2.4	1.2	1.5	1.8	1.7	0.2	5.2	1.48×10^2	7.6	0.11
61	76	0.9-1.9	4.8	3.6	4.5	4.4	0.7	20.3	5.12×10^2	4.2	0.29
61	76	0.0-0.9	3.2	1.6	2.3	2.1	0.6	13.1	3.22×10^2	3.0	0.28
76	91	1.9-2.4	1.2	3.1	2.2	2.1	0.2	5.8	1.04×10^2	7.1	0.14
76	91	0.9-1.9	4.4	8.7	6.2	6.0	1.1	20.3	3.60×10^2	4.2	0.35
76	91	0.0-0.9	3.1	4.0	3.8	3.6	0.9	13.7	2.36×10^2	3.2	0.34
91	95	0.0-2.4	1.7	6.4	2.5	2.6	0.5	8.6	96.0	4.0	0.28
95	100	0.0-2.4	2.0	19	1.5	1.4	0.7	13.7	83.4	4.1	0.48
0	100	0.0-2.4	59	61	51	52	49	253	1.30×10^4	3.9	

- In order to further increase the sensitivity, deep neural networks with several layers and multi-node architectures are being explored to improve the already good performance of the BDT

H to bb

- Final state with largest branching ratio $B(H \rightarrow bb) \sim 58\%$
- Large and nearly irreducible background processes (QCD)
- High- p_T Higgs production challenging to probe with cleaner final states ($H \rightarrow \gamma\gamma$, $H \rightarrow 4l$) due to lower branching ratios
- $H \rightarrow bb$ provide access to highest p_T Higgs bosons at the LHC

[10.1007/JHEP10\(2018\)101](https://arxiv.org/abs/10.1007/JHEP10(2018)101)

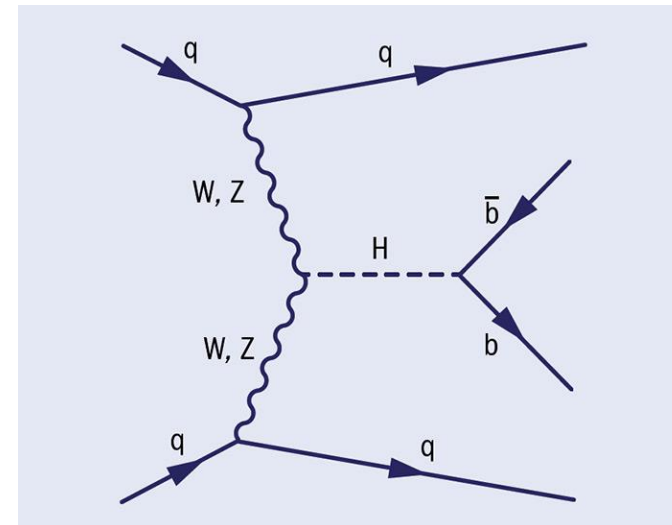
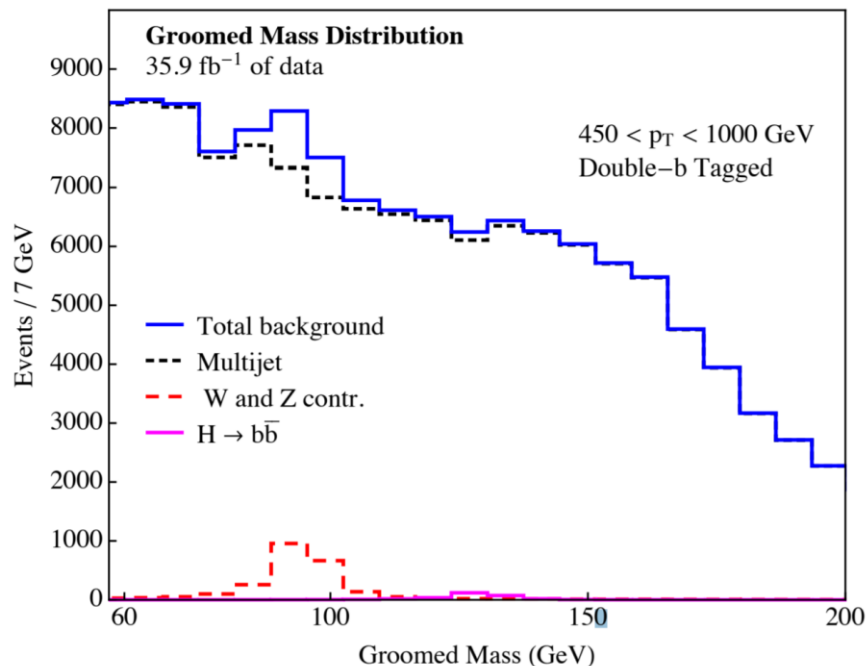

H to bb

- Two stream CNN used in this study
- The first stream uses the full event information
- The second stream uses the jet substructure information

[10.1007/JHEP10\(2018\)101](https://arxiv.org/abs/10.1007/JHEP10(2018)101)

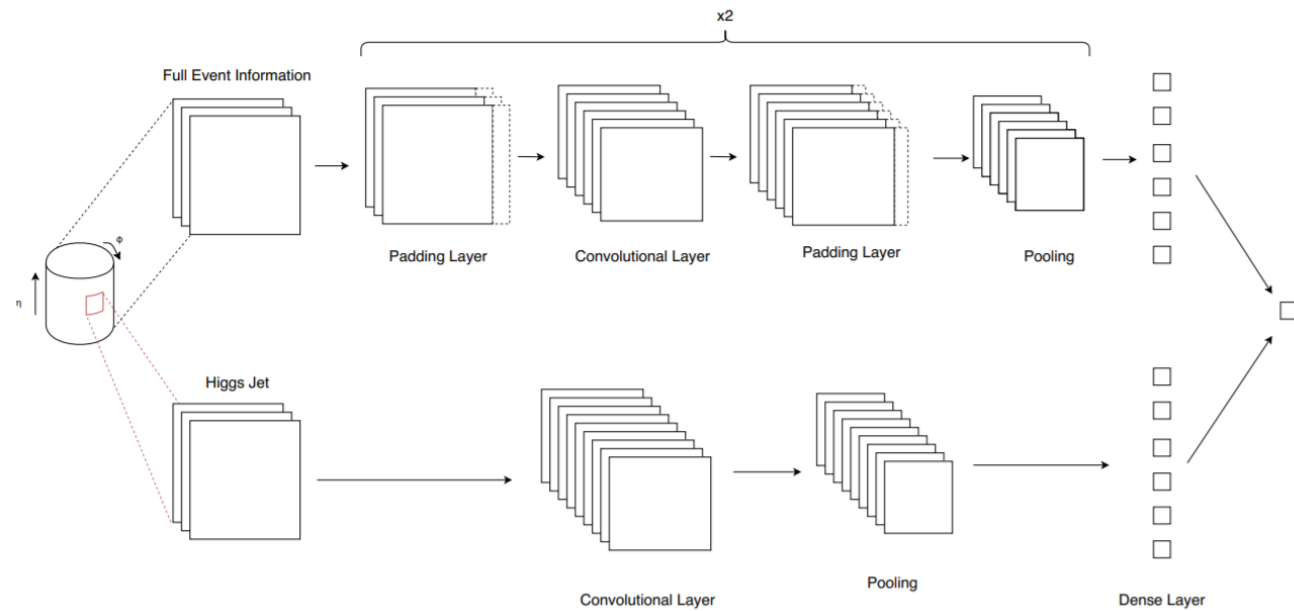
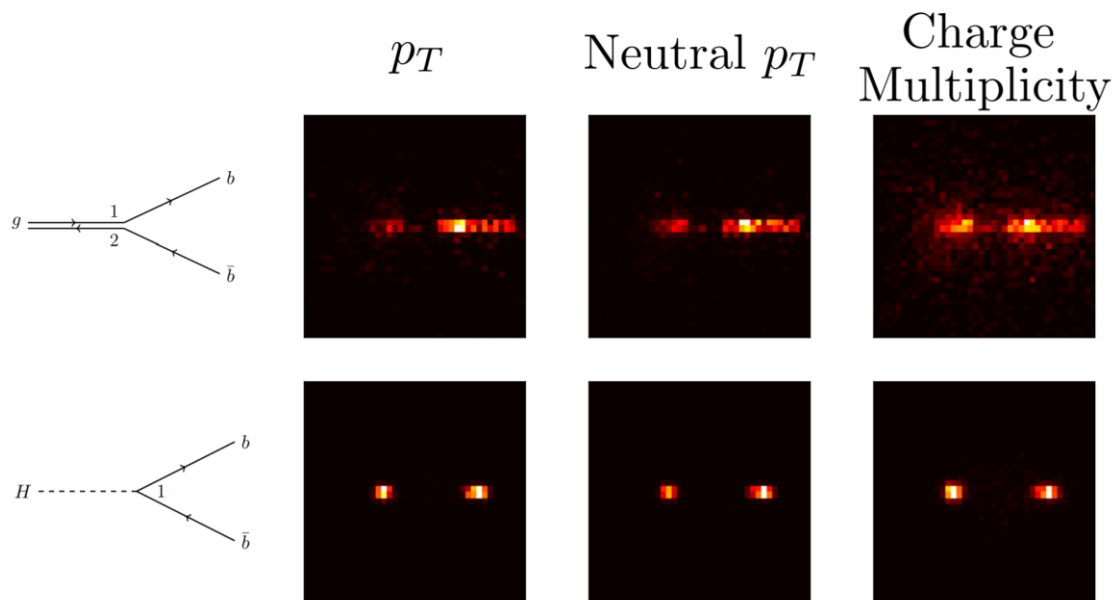

H to bb

[10.1007/JHEP10\(2018\)101](https://arxiv.org/abs/10.1007/JHEP10(2018)101)

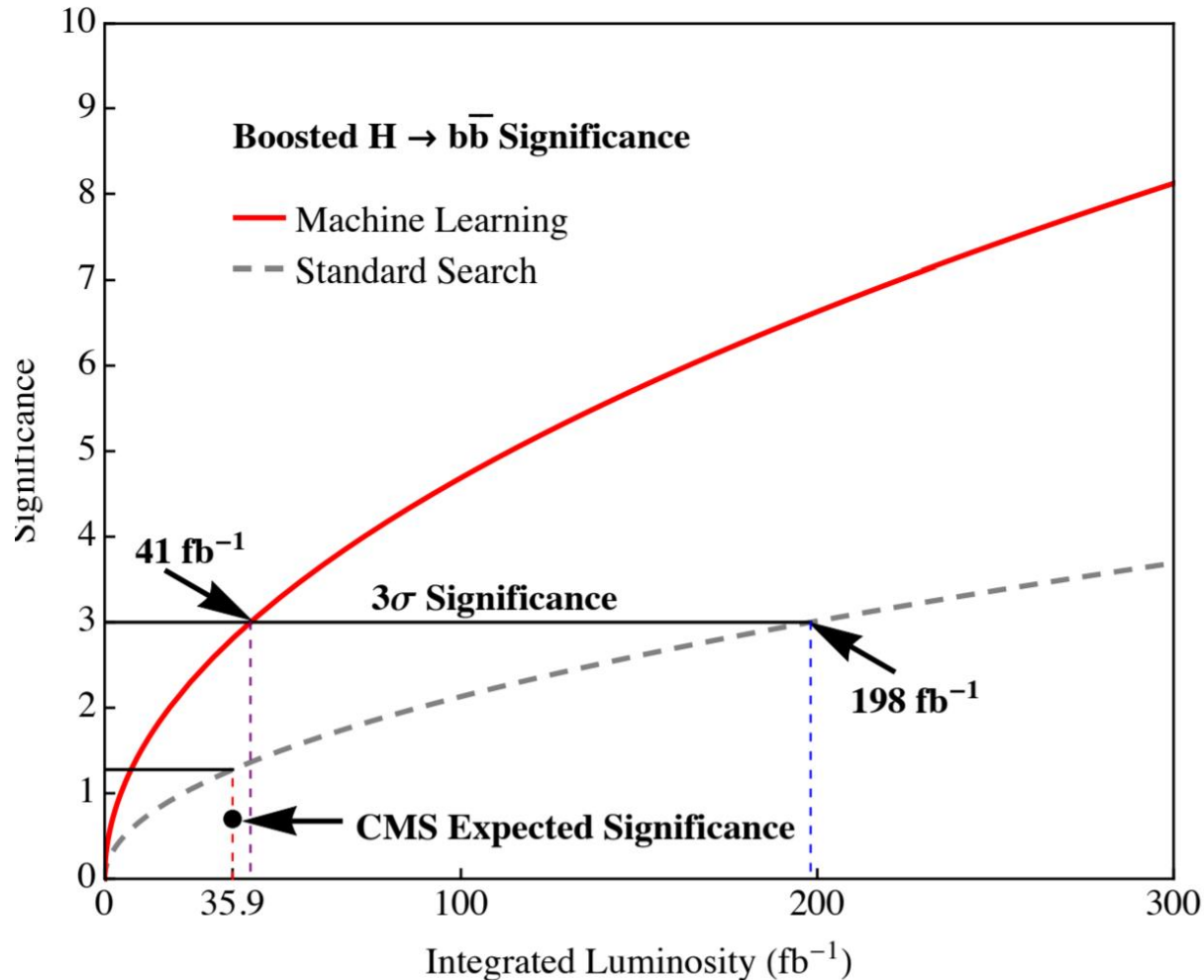

- Without ML “evidence” (3 sigma) may be achieved after LHC (2023) and “observation” may only be possible with HL-LHC
- With neural network evidence may be achievable with full Run 2 (2015-2018) 150 fb^{-1} and observation possible well before the end of the HL-LHC

Di-Higgs search

- One of the most challenging measurements at the HL/HL-LHC
- Di-Higgs production measurements probes trilinear self-coupling of the Higgs boson
- Main SM production mechanism is the gluon fusion

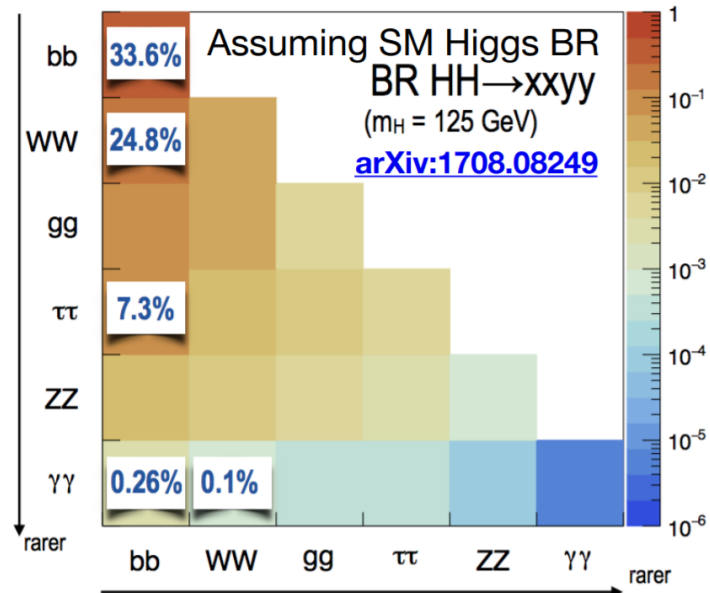
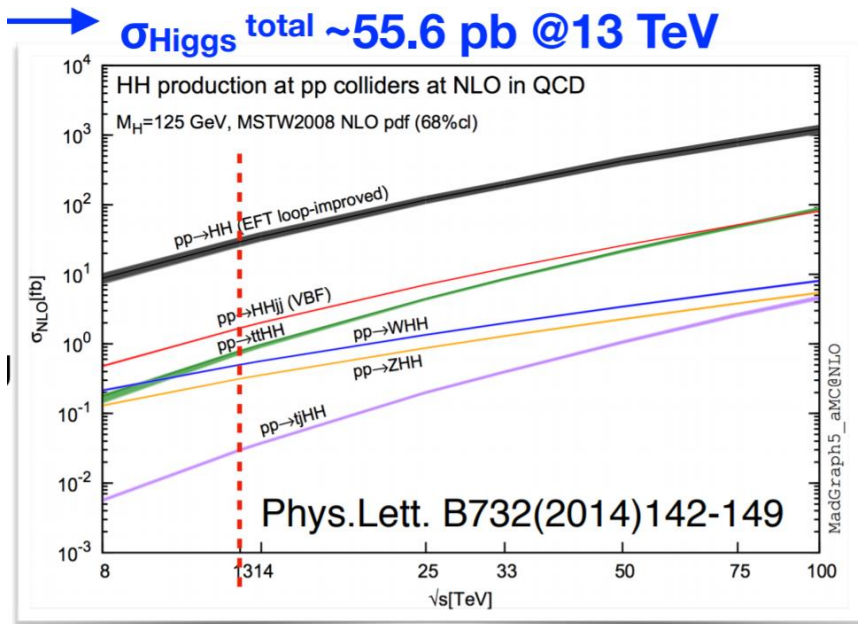
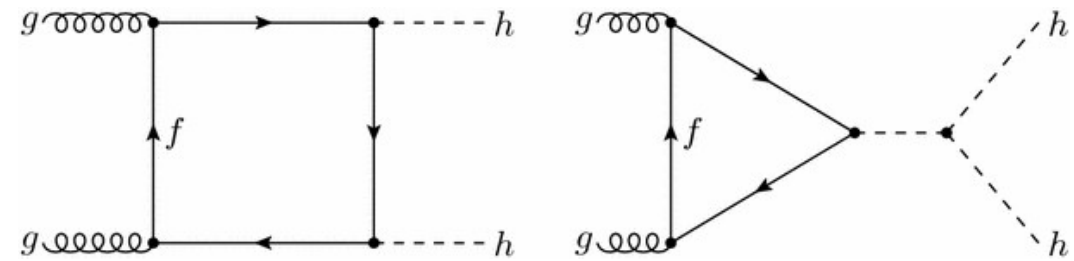

Di-Higgs search: bbVV

- Discriminating variables:

- Deep neural network using Keras library and parameterized machine learning technique, to optimize sensitivity in one training for full range of signal hypothesis tested (m_χ ; κ_λ , κ_t)
- Trained on event kinematics: m_{ll} , ΔR_{ll} , ΔR_{jj} , $\Delta\Phi(ll, jj\Phi)$, pT_{ll} , pT_{jj} , $\min(\Delta R_{jj})$, mT .

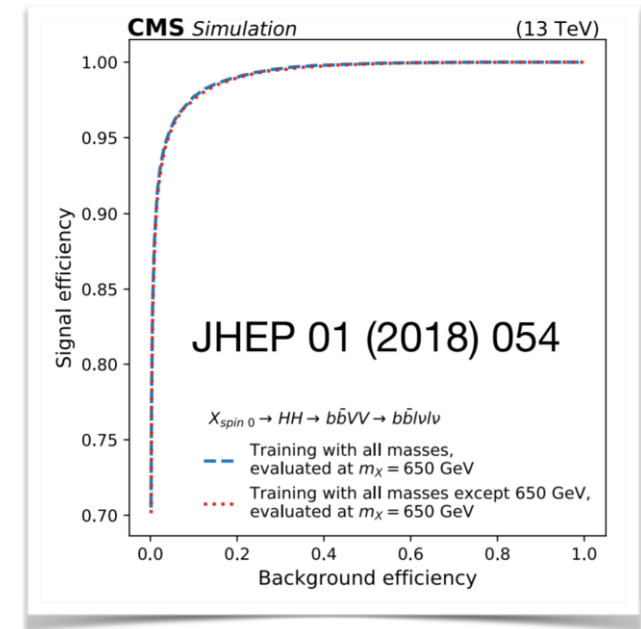
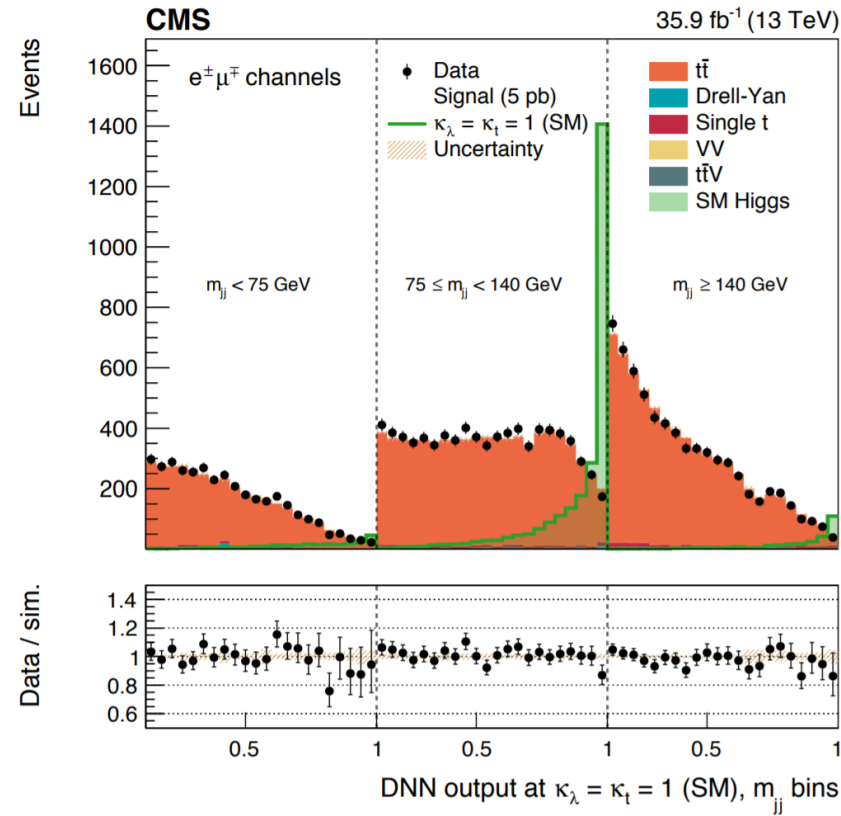

Di-Higgs search: $bb \tau \tau$

- Object selection:
 - A pair of tau leptons
 - Two b-tagged jets
- Signal region and discriminant variables
 - Both Higgs candidates' masses consistent with the expected reconstructed mass of the SM Higgs
 - Use of BDT to reject $t\bar{t}$ background

Phys. Lett. B 778 (2018) 101

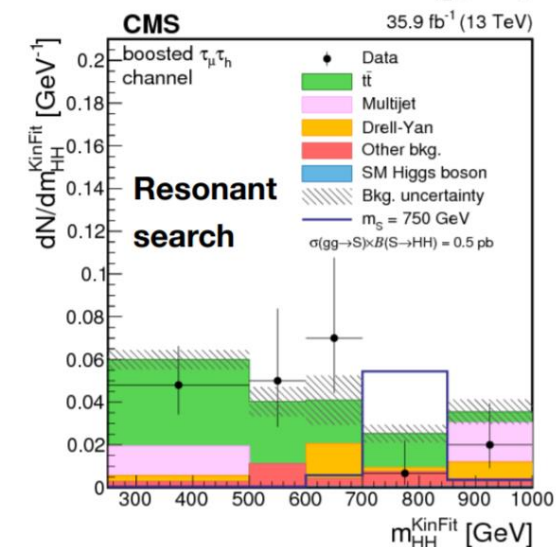
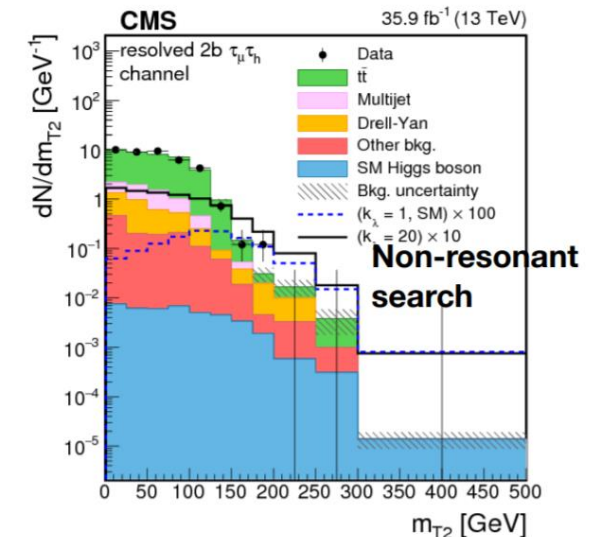

Higgs associated with top quark

- Higgs production associated with a pair of top quarks (ttH) in a final state with WbWbbb
- 8 objects in the final state
- A collection of variables used to test different neural network architectures

$$pp \rightarrow t\bar{t}h W^+bW^-b\bar{b} \rightarrow \ell\nu a' b\bar{b}b\bar{b}$$

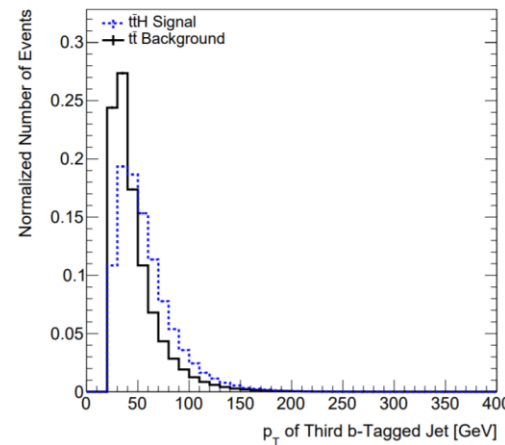
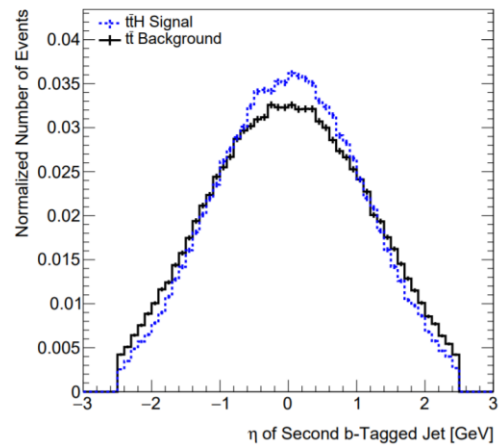
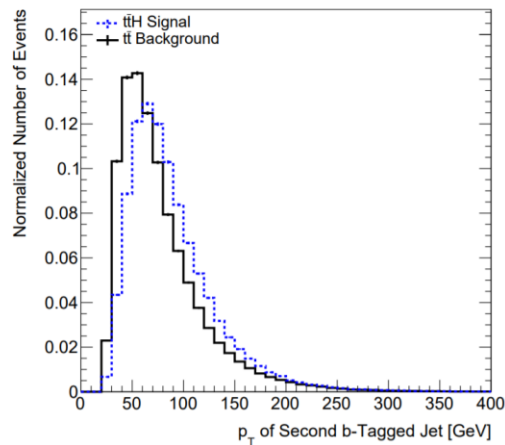
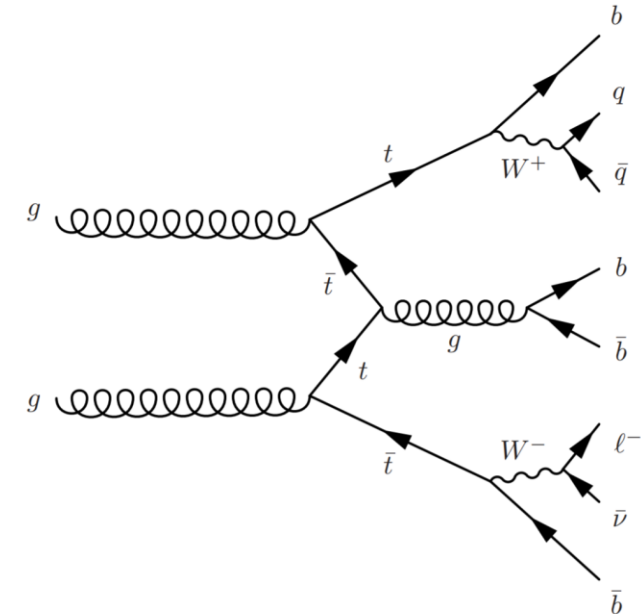
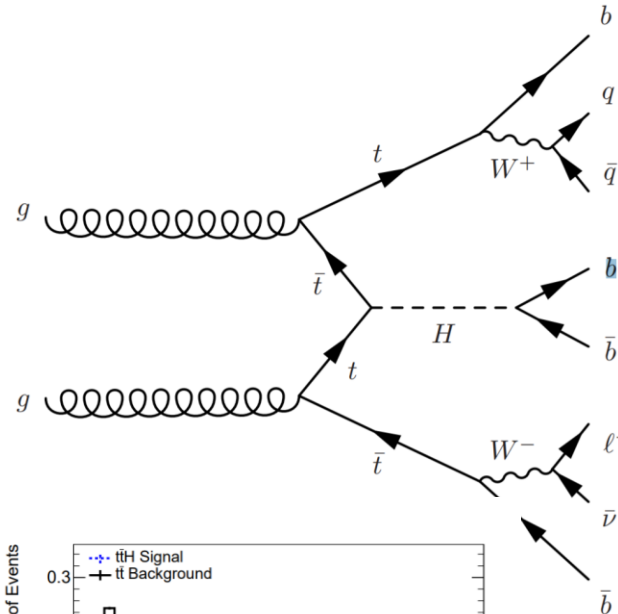

Higgs associated with top quark

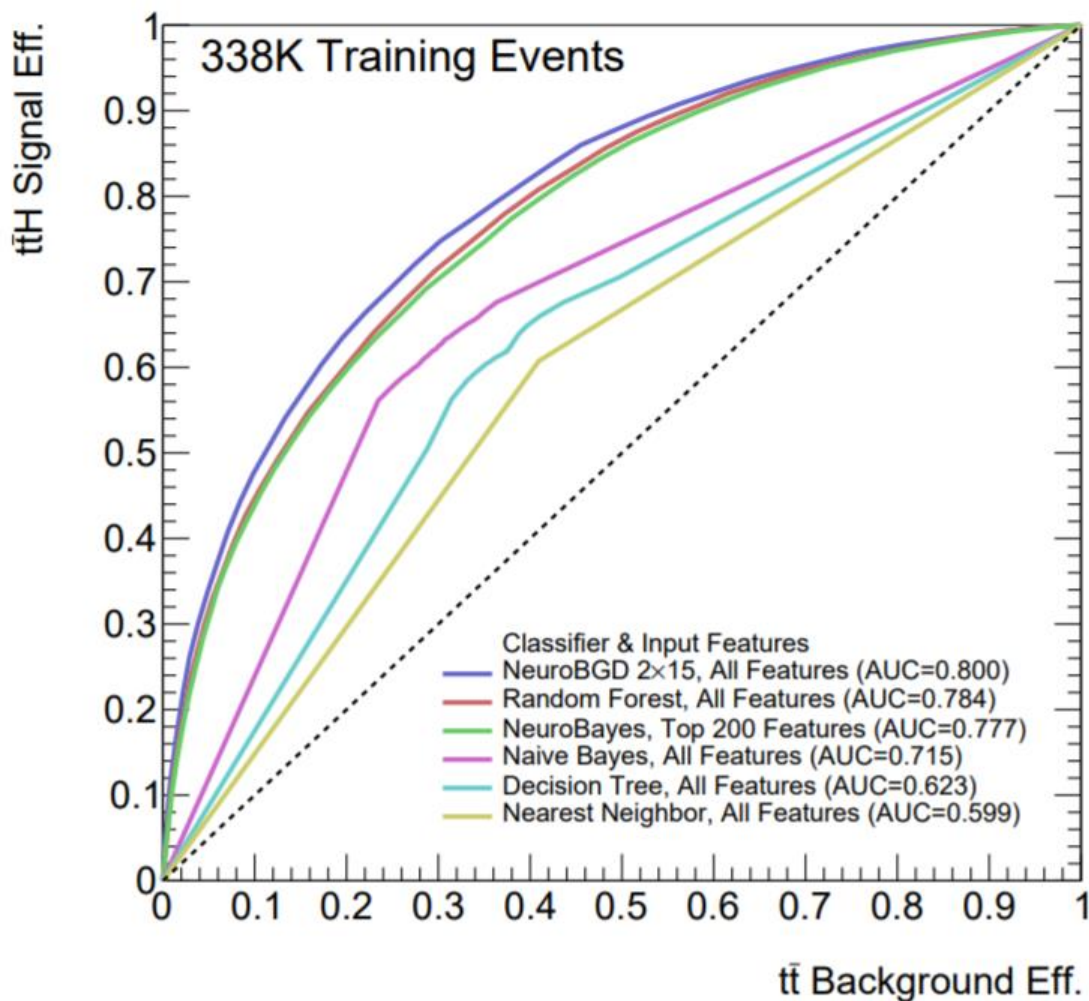

- Several ANN comparison
- ROC curves are one of the best tool to compare performance
- Best result with NeuroBGD which is a multilayer feed forward network that uses tanh activation function for hidden layers

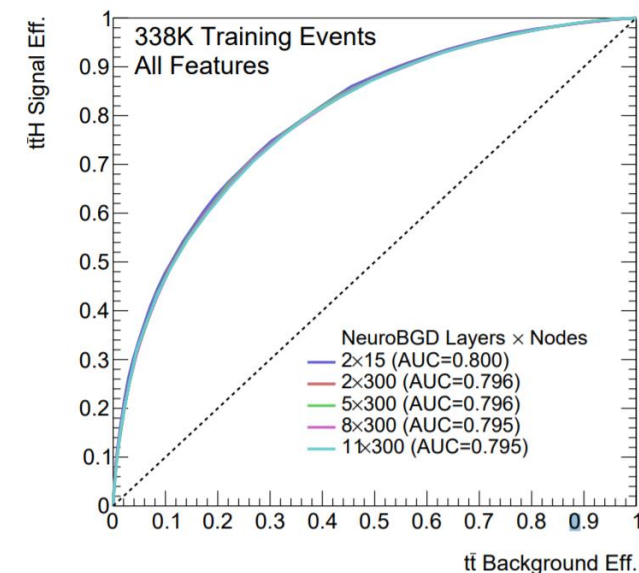
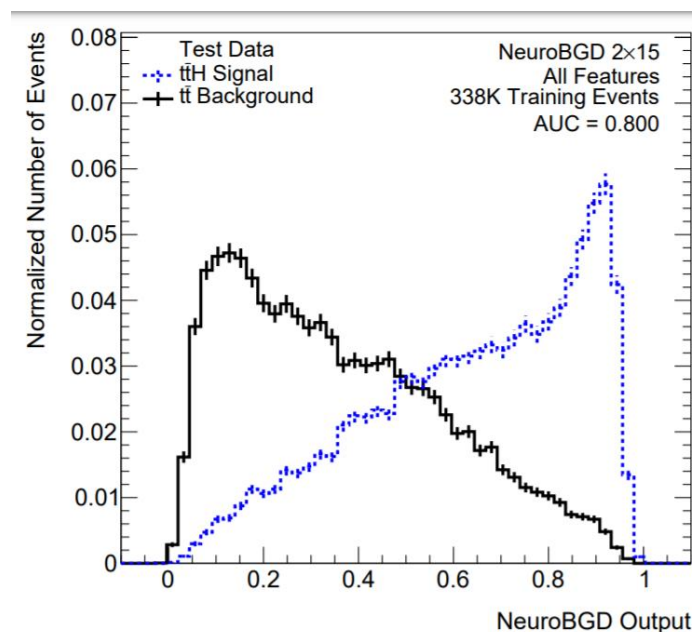

Conclusions

- The observation of fundamental processes such as the di-Higgs production and Higgs rare decays depend on the data accumulated in the following years and the development of new analysis techniques
- The integration of ML techniques for several final states increases signal purity and possibility of observation in the following years
- The scientific community needs to spend more computational resources and manpower to collaborate in such developments